

INVITATION TO BID

City and Borough of Wrangell

Park Benches and Trash Receptacles

Overview

The City and Borough of Wrangell, hereinafter referred to as the OWNER, invites sealed bids for the supply of Park Benches and Trash Receptacles, on a one-time basis. The successful Bidder shall furnish and deliver the product to Wrangell, Alaska.

Sealed bids will be received by the City and Borough of Wrangell, Post Office Box 531, Wrangell, Alaska 99929, or located at the Borough Clerk's Office, 205 Brueger Street, Wrangell, Alaska 99929, until **2:00 PM prevailing time on June 24, 2014**. The Bids will be publicly opened and read at 2:00 PM on June 20, 2014 in the City and Borough of Wrangell's Assembly Chambers in Wrangell, Alaska.

All bids must be submitted in sealed envelopes bearing on the outside the name of the project for which the bid is submitted. It is the sole responsibility of the Bidder to see that his bid is received in proper time. Any bids received after the scheduled closing time for receipt of bids will be returned to the Bidder unopened.

Instructions to Bidders

1. Bids should include a full description and brand name of the material being offered. All prices should be FOB Destination, Wrangell, Alaska.
2. Bids must be typewritten or completed with pen and ink, signed by the Bidder or their authorized representative, with all erasures or corrections initialed and dated by the official signing the Bid. Bids are to remain firm for a minimum of sixty (60) days.
3. Submit Bids plainly marked with "Park Benches and Trash Receptacles, City and Borough of Wrangell."
4. Modifications to Bids. Any Bidder may modify his bid by submitting a written modification signed by the Bidder. Modifications may be either hand delivered (205 Brueger Street, Wrangell, AK 99929), mailed (P.O. Box 531, Wrangell, AK 99929), faxed (Fax: 907-874-3952), or emailed (clerk@wrangell.com), provided such communication is received by the OWNER prior to the bid closing time. Modifications should not reveal the bid price but should provide the addition or subtraction, or other modification, so that the final prices or terms will not be known by the Owner until the sealed bid is opened.
5. Addenda. Each bid shall include specific acknowledgment in the space provided of receipt of all addenda issued during the bidding period. Failure to so acknowledge may result in the proposal being rejected as not responsive.

INVITATION TO BID
City and Borough of Wrangell
Park Benches and Trash Receptacles

6. The Bid Price shall include everything necessary for the fulfillment of the contract, including, but not limited to, furnishing all materials and equipment, except as may be provided otherwise in the Contract Documents. In the event of a difference between a price quoted in words and a price quoted in figures for the same bid, the words shall be the amount bid.

Standards for Acceptance of Bids for Awarded Contract

The OWNER reserves the right to reject any or all bids, waive any informalities or irregularity in the bidding and/or not make an award. The award of the Contract, if made by the OWNER, will be made to the qualified and responsible Bidder submitting the lowest responsive bid, but the OWNER shall determine at its own discretion whether a Bidder is responsible and qualified to perform the Contract, and what bid is the lowest or in the best interest of the OWNER. "Best interest of the Owner" includes the OWNER's right to consider a potential substitute product design or any other matters to be submitted pursuant to the Contract Documents in making its determination, and determine whether it is to the best interest of the OWNER to accept the bid. The City and Borough of Wrangell reserves the right to modify the contract after its award.

General Terms and Conditions

1. Specification Discrepancies: Any obvious error or omission in specifications shall not be to the benefit of the Bidder but shall put the Bidder on notice to inquire of or identify the same from the City and Borough of Wrangell. Whenever mention is made of any article, material, or workmanship to be in accordance with laws, ordinances, codes, underwriter's codes, A.S.T.M. regulations or similar expressions, the requirements of these laws, ordinances, etc., shall be construed to be the minimum requirements of these specifications.
2. Delivery Point: All items offered shall be on the delivery basis of FOB Destination: City and Borough of Wrangell, Wrangell, Alaska 99929. Delivery cost shall be included in the Bid price.
3. Delivery Time: All items shall be received within 90 days of the date of Bidder's receipt of a City and Borough of Wrangell purchase order; otherwise, Liquidated Damages in the amount of \$250/calendar day will be paid by the Bidder against the contract price.

Description of Materials

Bids for materials and supplies should include a complete description, manufacturer's name, and manufacturer's specification data sheets, including optional materials and colors used to determine complete and final product.

Quality

All materials used for the manufacture or construction of any materials or equipment covered by this Bid shall be new (unless otherwise specified as recycled or repurposed), of the latest model, of the best quality, and of the highest grade workmanship. It is the Bidder's responsibility to

INVITATION TO BID
City and Borough of Wrangell
Park Benches and Trash Receptacles

prove to the City and Borough of Wrangell that each item offered is equal to the grade or quality of material specified.

Acceptance of Material

The materials delivered under this Bid shall remain the property of the Bidder until a physical inspection and actual usage of this material and/or services is made and therefore accepted to the satisfaction of the City and Borough of Wrangell.

Warranty

All manufactured products shall be warrantied against defect in materials and/or workmanship and in accordance with these specifications. The manufacturer shall further warrant their products offered hereunder as follows:

- A. Limited 20-year warranty against structural failure of all steel bench frames or complete steel bench assemblies and litter receptacle frames and all cast iron bench supports.
- B. Limited 10-year warranty against structural failure of recycled plastic. It is further warrantied not to degrade, split, crack or splinter during this 10-year period.
- C. Limited 1-year warranty on any item not specifically mentioned above.

Compliance with Specifications

Terms and Conditions: The Invitation to Bid, General Conditions, Instructions to Bidder, Specifications, Special Conditions, Bid, Addendum, and/or any other pertinent documents form a part of this Bid and by reference are made a part hereof.

Invoices should be mailed to the following address

City and Borough of Wrangell
P.O. Box 531
Wrangell, Alaska 99929
Attn: Accounts Receivable
Payment Terms- Net 30 Days after invoice date and acceptance of goods

Point of Contact

Amber Al-Haddad, Parks & Recreation Director, City and Borough of Wrangell
Tel: 907-305-1150
Email: aal-haddad@wrangell.com

INVITATION TO BID

City and Borough of Wrangell

Park Benches and Trash Receptacles

Park Bench and Trash Receptacle Specifications

The City and Borough of Wrangell requires 14-each park benches and 14-each trash receptacles with the following specifications: The basis of design for the products shall be DuMor Site Furnishings' Bench 57 and Receptacle 124-31PL, or approved equal, meeting the minimum fabrication and design standards as follows:

Park Bench

- DuMor Bench 57, Steel / Plastic Bench with Back Support, 6'-long.
- Cast Iron Steel Frame/Supports with rosette design.
- Steel member's coatings of zinc-rich epoxy primer, then finished with a TGIC-polyester powder coating, Green color to match Wrangell's existing street light poles (Sherwin Williams paint color powder# PGS5-00522, was Fuller# IF7725M WET # F78XXG3237).
- Seat surface constructed with 2" x 3" recycled HDPE plastic slats with a wood appearance, Cedar color.
- Rated to support at least 229 lbs.
- Include all necessary surface mounting plates and expansion anchor bolts (for surface mount to concrete slab).
- Quantity: Fourteen (14) each

Trash Receptacle

- DuMor Receptacle 124-31PL, Steel / Plastic Trash Receptacle, 3'-high.
- Steel Frame with rosette design at top of frame (to match bench rosette design)
- Steel member's coatings of zinc-rich epoxy, then finished with a polyester powder coating, Green color to match Wrangell's existing street light poles (Sherwin Williams paint color powder# PGS5-00522, was Fuller# IF7725M WET # F78XXG3237).
- Exterior constructed with vertical 2" x 3" recycled HDPE plastic slats with a wood appearance, Cedar color.
- Receptacle cover shall include a bonnet top to keep the rain from entering the receptacle. Top shall be attached to the base by a vinyl-coated cable.
- Minimum 30-Gallon Capacity with Galvanized interior liner.
- Include all necessary surface mounting plates and expansion anchor bolts (for surface mount to concrete slab).
- Quantity: Fourteen (14) each

INVITATION TO BID
City and Borough of Wrangell
Park Benches and Trash Receptacles

BID

Bid To: City and Borough of Wrangell, Alaska

1. The undersigned Bidder offers and agrees, if this Bid is accepted, to enter into an Agreement with the Owner to perform the work as described in the contract documents entitled *Invitation to Bid, City and Borough of Wrangell, Park Benches and Trash Receptacles*.
2. Bidder accepts all of the terms and conditions of the contract documents, including without limitations those in the Request for Bid.
3. The Bid will remain open for 60 days, as stipulated in the Invitation to Bid.
4. The Bidder agrees to complete the work required under the contract documents within the time stipulated and accepts payment in full based on the contract price named in the Bid.
5. Bidder has examined the contract documents in full, including the following Addenda, receipt of which is hereby acknowledged by the undersigned:

<u>ADDENDUM NUMBER</u>	<u>DATE OF RECEIPT OF ADDENDUM</u>	<u>SIGNED ACKNOWLEDGMENT</u>
1		
2		

(Note: Failure to acknowledge receipt of any addenda may be considered an irregularity in the proposal and grounds for rejection of the bid.)

6. The Bidder has read this Bid and agrees to the conditions as stated herein by providing their signature in the space provided below.

Bid Item

Lump Sum Price

DuMor Park Benches #57 and DuMor Trash
 Receptacles #124-31PL (FOB Wrangell)

\$ _____

Bidder's Name: _____

Bidder's Representative's Signature: _____

Bidder's Address: _____

Bidder's Telephone/Fax Numbers: _____

Bidder's Business License No.: _____

Date: _____

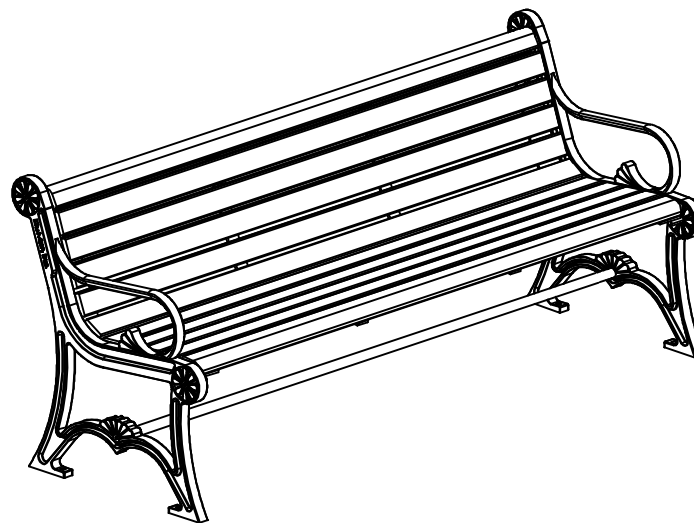
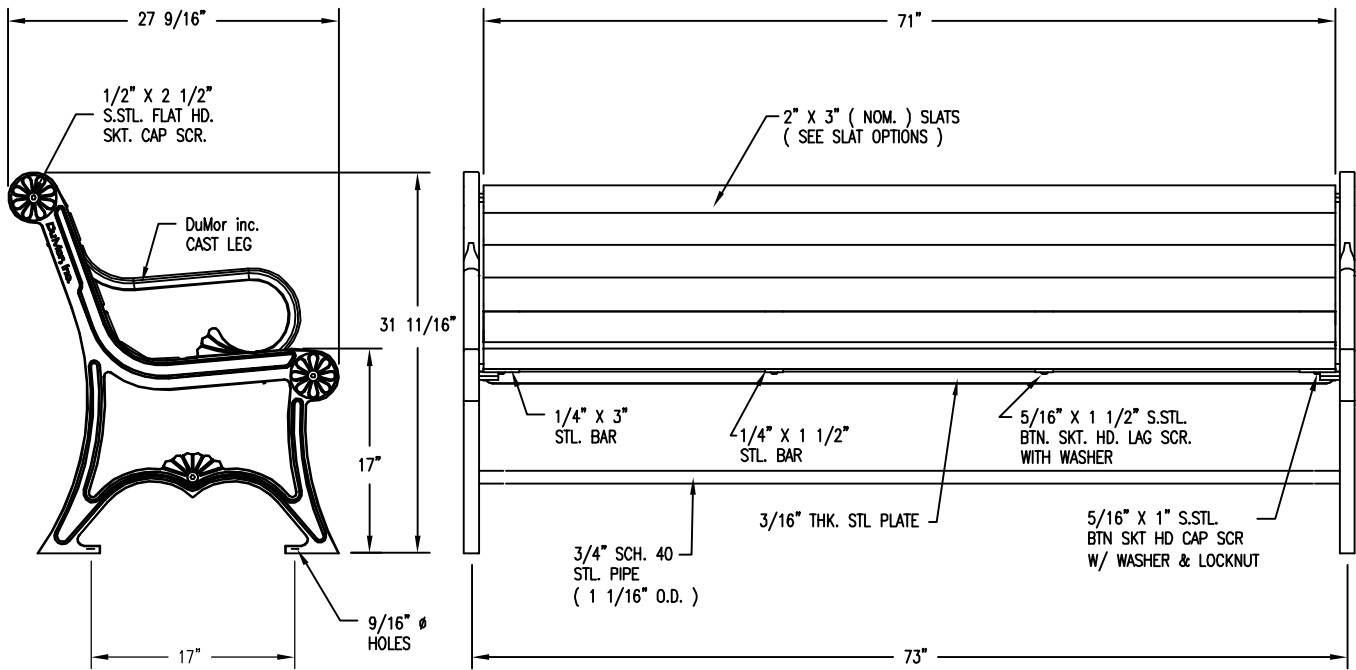

CUSTOM LETTERING (37 SPACES) _____

NOTES

- 1.) ALL STL. MEMBERS COATED W/ ZINC RICH EPOXY THEN FINISHED W/ POLYESTER POWDER COATING.
- 2.) 1/2" X 3 3/4" EXPANSION ANCHOR BOLTS PROVIDED.
- 3.) CUSTOM LETTERING AVAILABLE FOR RECESSED SIDE PANELS (TOTAL OF 37 SPACES).

SLAT OPTIONS

- "CEDAR" RECYCLED PLASTIC
- "GREY" RECYCLED PLASTIC
- "REDWOOD" RECYCLED PLASTIC
- "WALNUT" RECYCLED PLASTIC
- OTHER _____



DuMor, inc.
P.O. Box 142 Mifflintown, PA 17059-0142

SCALE : NONE
DATE DRAWN : 12/11/01
DRAWN BY : AH
DATE REV. : 10/25/11
REV. BY : RDH

TITLE : BENCH

REV. E

DRAWING NUMBER

57-60PL

SHEET 1 OF 2

NOTE:

- 1.) DURING ASSEMBLY PROCEDURE;
DO NOT COMPLETELY TIGHTEN HARDWARE.
- 2.) THE ACTUAL PARTS WILL NOT BE NUMBERED.
NUMBERS ONLY APPLY TO DRAWING.

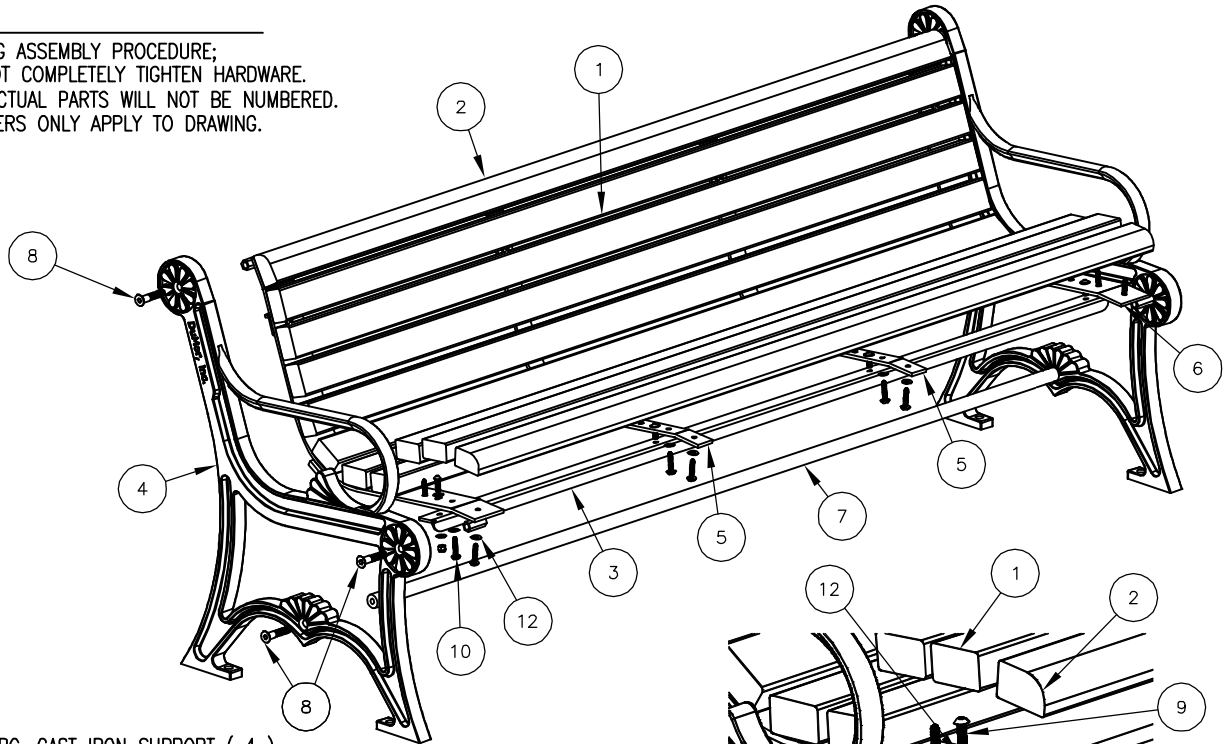

STEP 1:

- USE 2 - PC. CAST IRON SUPPORT (4)
 1 - PC. 71 3/4" PIPE BRACE (7)
 2 - PCS. 1/2" X 2 1/2" FLT. SKT. HD. CAP SCR. (8)
- ATTACH CAST IRON BENCH SUPPORT (4) TO 71 3/4" PIPE BRACE (7) USING HARDWARE (8). TIGHTEN TO SNUG FIT.

STEP 2:

- USE 2 - PCS. END CONTOUR STRAP (6)
 4 - PCS. 1/2" X 2 1/2" FLT SKT. HD. CAP SCR. (8)
- ATTACH END CONTOUR STRAPS (6) TO STEP 1 ASSEMBLY USING HARDWARE (8). TIGHTEN TO SNUG FIT.

STEP 3:

- USE 2 - PCS. 71" SEAT BRACE (3)
 4 - PCS. 5/16" X 1" SS. BTN SKT HD CAP SCR (9)
 4 - PCS. 5/16" SS. NYLON LOCKNUT (11)
 8 - PCS. 5/16" SS. FLAT WASHER (12)
- ATTACH 71" SEAT BRACE (3) TO STEP 2 ASSEMBLY USING HARDWARE (9, 11 & 12). TIGHTEN TO SNUG FIT.

STEP 4:

- USE 2 - PCS. CENTER CONTOUR STRAP (5)
 4 - PCS. 5/16" X 1" SS. BTN SKT HD CAP SCR (9)
 4 - PCS. 5/16" SS. NYLON LOCKNUT (11)
 8 - PCS. 5/16" SS. FLAT WASHER (12)
- ATTACH CENTER CONTOUR STRAP (5) TO STEP 3 ASSEMBLY USING HARDWARE (9, 11 & 12). TIGHTEN TO SNUG FIT.

STEP 5:

- USE 9 - PCS. 2" X 3" X 71" PLASTIC INT'R SLAT (1)
 2 - PCS. 2" X 3" X 71" PLASTIC EDGE SLAT (2)
 44 - PCS. 5/16" X 1 1/2" SS. BTN. SKT. HD. LAG (10)
 44 - PCS. 5/16" SS. FLAT WASHER (12)
- ATTACH 2" X 3" X 71" PLASTIC SLATS (1 & 2) TO STEP 4 ASSEMBLY USING HARDWARE (10 & 12). TIGHTEN TO SNUG FIT.
 REPEAT UNTIL ALL SLATS ARE ATTACHED.

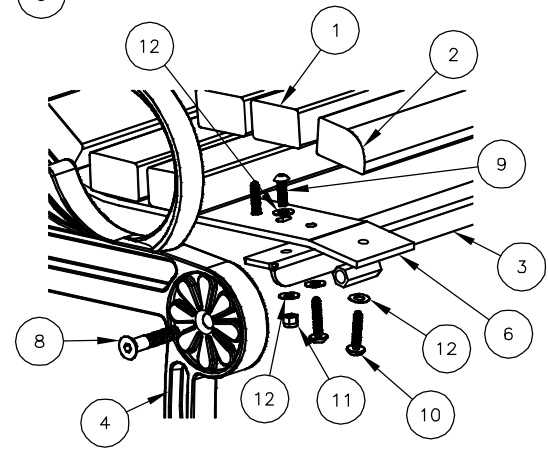

DETAIL A

STEP 6:

UPON COMPLETION OF BENCH ASSEMBLY SQUARE ALL COMPONENTS THEN TIGHTEN ALL HARDWARE.

STEP 7:

MOUNT AND ANCHOR AS SPECIFIED.

ITEM	QTY	PART NO	DESCRIPTION
1	9	0-143-60PL-01	2" X 3" X 71" PLASTIC INT'R SLAT
2	2	0-143-60PL-02	2" X 3" X 71" PLASTIC EDGE SLATS
3	2	0-16-60-06	71" SEAT TUBE BRACE
4	2	0-57-00-02	CAST IRON BENCH SUPPORT
5	2	0-57-00-03	CENTER CONTOUR STRAP
6	2	0-57-00-05	END CONTOUR STRAP
7	1	0-57-60-04	71 3/4" PIPE BRACE
8	6	1-12-065	1/2" X 2 1/2" FLT SKT HD CAP SCR
9	8	1-12-116	5/16" X 1" SS BTN SKT HD CAP SCR
10	44	1-13-023	5/16" X 1 1/2" SS BTN SKT HD LAG
11	8	1-20-016	5/16" SS NYLON LOCKNUT
12	60	1-22-017	5/16" SS FLAT WASHER

DuMor, inc.
 P.O. Box 142 Mifflintown, PA 17059-0142

SCALE : NONE
 DATE DRAWN : 12/11/01
 DRAWN BY : AWH
 DATE REV. : 10/25/11
 REV. BY : RDH

TITLE : BENCH ASSEMBLY

REV. E	DRAWING NUMBER 57-60PL	SHEET 2 OF 2
--------	------------------------	--------------

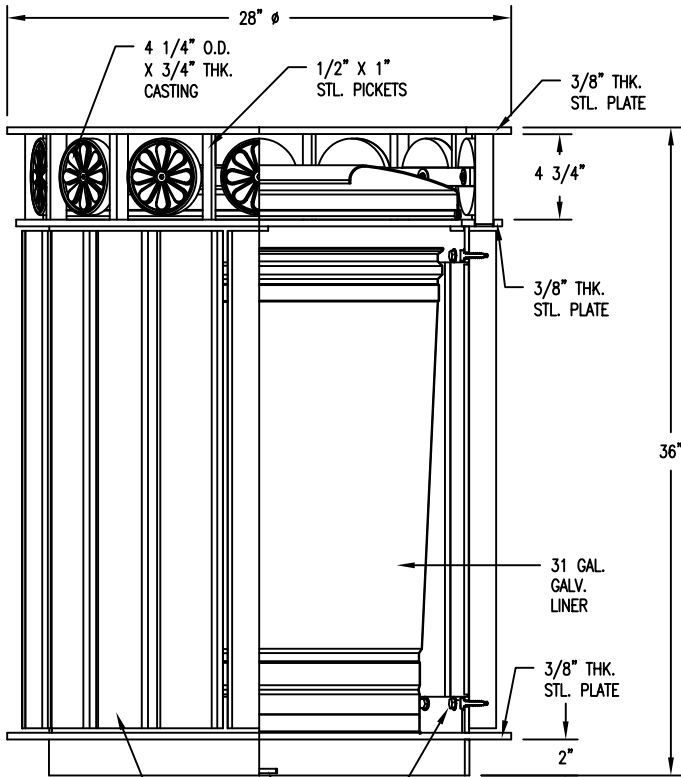
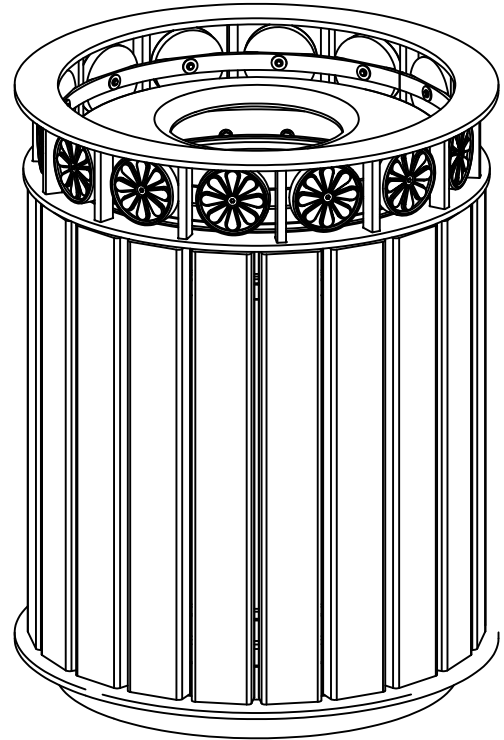
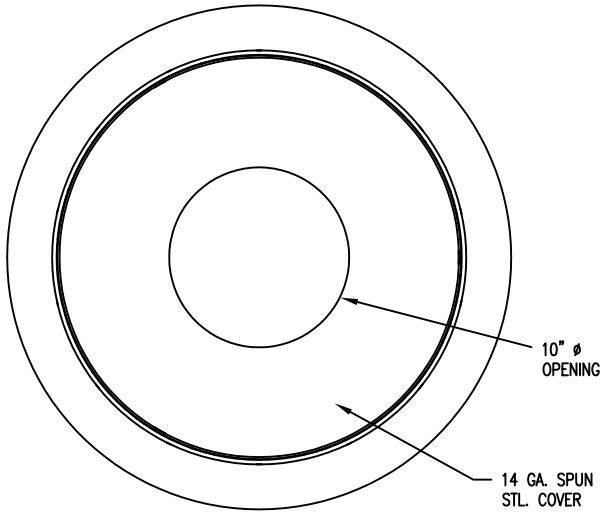

2" X 4" (NOM.) SLATS
(SEE SLAT OPTIONS)

1/4" THK. STL. PLATE W/
11/16" ϕ ANCHOR HOLE
(3-PLACES)

5/16" X 1 1/4" S.STL.
HEX HD. LAG SCR.
W/ WASHER

NOTES

- 1.) ALL STL. MEMBERS COATED W/ ZINC RICH EPOXY THEN FINISHED W/ POLYESTER POWDER COATING.
- 2.) 1/2" X 3 3/4" EXPANSION ANCHOR BOLTS PROVIDED.
- 3.) RECEPTACLE FULLY ASSEMBLED AT FACTORY.

SLAT OPTIONS

- "CEDAR" RECYCLED PLASTIC
- "GREY" RECYCLED PLASTIC
- "REDWOOD" RECYCLED PLASTIC
- "WALNUT" RECYCLED PLASTIC
- OTHER _____

DuMor, inc.
P.O. Box 142 Mifflintown, PA 17059-0142

SCALE : NONE
DATE DRAWN : 7/18/00
DRAWN BY : CDC
DATE REV. : 10/26/11
REV. BY : ESS

TITLE : RECEPTACLE

REV. E

DRAWING NUMBER

124-31PL-FTO

SHEET 1 OF 2

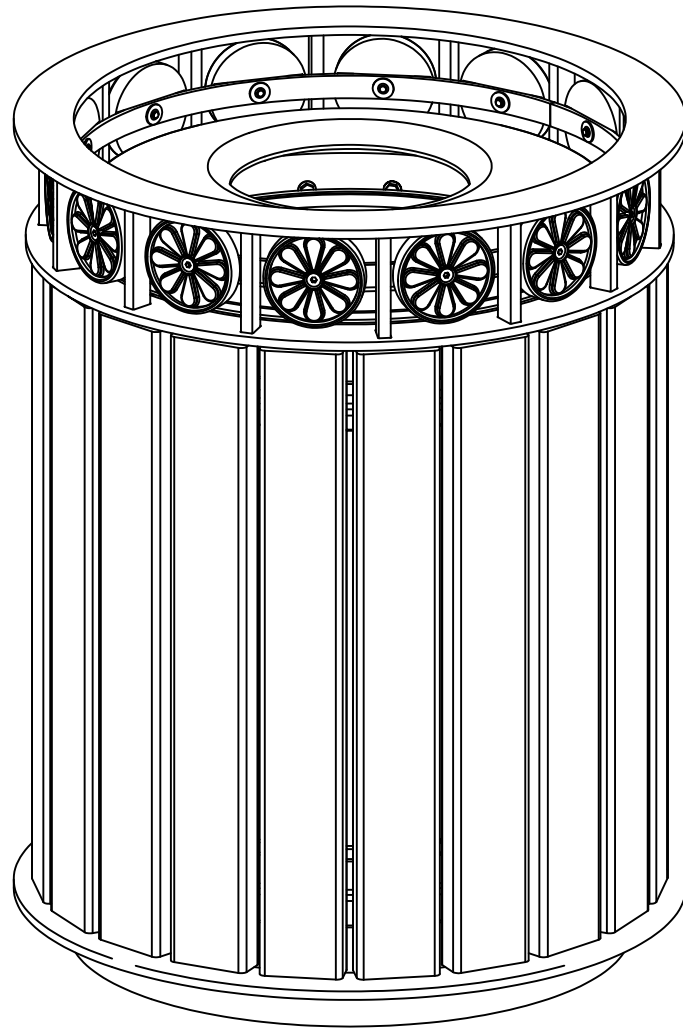

NOTE:

- 1.) RECEPTACLE SHIPPED FULLY ASSEMBLED.
- 2.) COVER ATTACHED W/ 1/8" VINYL COATED CABLE.
- 3.) MOUNT AND ANCHOR AS SPECIFIED.



DuMor, inc.

P.O. Box 142 Mifflintown, PA 17059-0142

SCALE :	NONE
DATE DRAWN :	8/28/01
DRAWN BY :	JSB
DATE REV. :	12/2/09
REV. BY :	JSB

TITLE :		RECEPTACLE ASSEMBLY	
REV.	D	DRAWING NUMBER	124-31PL-FT0
			SHEET 2 OF 2