



CITY & BOROUGH OF WRANGELL SPECIAL ASSEMBLY MEETING AGENDA

Thursday, March 15, 2018
7:00 p.m.

Location: Assembly Chambers,
City Hall

1. Call to Order
2. Roll Call
3. Conflict of Interest:
4. Persons to be Heard:
5. Item(s) of Business:
 - a. Discussion regarding the options of a DAF System as the solution for the Water Treatment Plant
 - b. **PROPOSED RESOLUTION NO. 03-18-1394:** A RESOLUTION OF THE ASSEMBLY OF THE CITY & BOROUGH OF WRANGELL, ALASKA, APPROVING THE DAF SYSTEM AS THE SOLUTION FOR THE WATER TREATMENT PLANT CAPITAL IMPROVEMENT PROJECT AND ASSOCIATED FUNDING PLAN (*postponed from the February 27th and March 13^t Assembly Meetings*)
6. Adjournment

CITY & BOROUGH OF WRANGELL, ALASKA
SPECIAL ASSEMBLY AGENDA STATEMENT

<u>AGENDA ITEM TITLE:</u>	<u>NO.</u>	5a	<u>DATE:</u>	March 15, 2018
---------------------------	------------	----	--------------	----------------

Discussion regarding the options of a DAF System as the solution for the Water Treatment Plant

<u>SUBMITTED BY:</u>	<u>FISCAL NOTE:</u>
	Expenditure Required:
Amber Al-Haddad, Public Works Director	Amount Budgeted:
	Account Number(s):
	Account Name(s):
<u>Reviews/Approvals/Recommendations</u>	
	Unencumbered Balance (prior to expenditure):
n/a	Borough Assembly
n/a	Attorney
n/a	Insurance

ATTACHMENTS:

RECOMMENDATION:

Discussion....

SUMMARY STATEMENT:

CITY & BOROUGH OF WRANGELL, ALASKA
SPECIAL ASSEMBLY AGENDA STATEMENT

<u>AGENDA ITEM TITLE:</u>	<u>NO.</u>	5b	<u>DATE:</u>	March 15, 2018
RESOLUTION NO. 03-18-1394: A RESOLUTION OF THE ASSEMBLY OF THE CITY & BOROUGH OF WRANGELL, ALASKA, APPROVING THE DISSOLVED AIR FLOTATION (DAF) SYSTEM AS THE SOLUTION FOR THE WATER TREATMENT PLANT CAPITAL IMPROVEMENT PROJECT AND THE ASSOCIATED FUNDING PLAN				
<u>SUBMITTED BY:</u>		<u>FISCAL NOTE:</u>		
		Expenditure Required: \$9,182,000 (see detailed Fiscal Note in Summary Statement)		
Amber Al-Haddad, Public Works Director		Amount Budgeted:		
		Account Number(s):		
		Account Name(s):		
<u>Reviews/Approvals/Recommendations</u>				
<input checked="" type="checkbox"/>	Borough Assembly		Unencumbered Balance (prior to expenditure):	
n/a	Attorney			
n/a	Insurance			
<u>ATTACHMENTS:</u>				
<ol style="list-style-type: none"> Resolution No. 03-18-1394 Memorandum from Amber Al-Haddad, Director of Public Works dated January 29, 2018, with recommendation to adopt the DAF system as the long-term solution for the water treatment plant's capital improvements project. Memorandum from CRW Engineering Group dated January 24, 2018, including Final Recommendation and Construction Cost Estimate for the DAF Treatment Plant Improvements project. 				

Mayor: There was a motion on the floor however since the Resolution number has changed, I would entertain a new motion.

RECOMMENDED MOTION:

Move to approve Resolution No. 03-18-1394, approving the Dissolved Air Flotation system as the solution for the water treatment plant capital improvement project and its associated funding plan.

SUMMARY STATEMENT:

Following nearly two years of water treatment methods' review and analysis, staff recommend adopting Alternative 2 of the CRW Engineering Group, LLC's January 24, 2018 Memorandum entitled Water Treatment Upgrades: Final Evaluation and Recommendation and construct a new water treatment facility based on the Dissolved Air Flotation (DAF) treatment process.

Attached is a construction cost estimate for the Water Treatment Plant Improvements project, based on implementation of a Dissolved Air Flotation (DAF) treatment system, totaling \$9,182,000. This estimate was developed by CRW Engineers, based on their development of a Preliminary Engineering Report (PER) which evaluated five water treatment alternates. The preferred alternative is the DAF treatment system.

FISCAL IMPACT:

The total cost of the construction project is \$9,182,000, which will be funded through the following sources:

Water Fund Contribution:	\$ 119,000
EDA Grant:	\$2,081,000
USDA Loan:	\$3,821,000
USDA Grant:	<u>\$3,161,000</u>
Total Project Funding	\$9,182,000

Because it is unknown at this time, the project cost listed above does not include the interim financing cost that is required by USDA. Lee Burgess, Finance Director, has begun discussions with various financial institutions to explore interim financing options. Interim financing costs are allowable project costs.

With the USDA Loan and Grant funding currently in place, the feasibility of the Water Treatment Plant Improvements project, based on DAF treatment process, is dependent on the level of success at securing the EDA grant funding for the remaining funding needs.

USDA has agreed to fund a portion of the improvements project, based on the construction and upgrades to the Water Treatment Plant to house two parallel Dissolved Air Flotation (DAF) with multimedia filtration, and a backwash waste disposal to recycle the backwash water from the water treatment plant. This funding is specific to the DAF project.

EDA is waiting for Wrangell's application for funding for the water treatment improvements project. EDA staff have indicated that the project application needs to identify the project specifics, which means we have to identify those specific improvements related to the selected project. If the project were to change, the application would be canceled and those Alaska-based EDA funds would be returned to EDA's national office. This would not only hurt Wrangell, it would also negatively impact the EDA Alaska region. Therefore the preferred project must be identified in the grant application to EDA. The local match for the EDA grant has been identified as the USDA loan and its required interim financing. The EDA program staff indicate that a funding decision would be made known to Wrangell within 180 days of submitting an application.

With this sequence of funding planning, the water treatment plant's capital improvements project would be on hold until a response to the CBW's EDA grant application is received.

Staff recommend approving the Dissolved Air Flotation system as the solution for the water treatment plant capital improvement project and its associated funding plan. All funds secured for the project would be consolidated into one CIP account for the Water Treatment Plant Improvements project.

CITY AND BOROUGH OF WRANGELL, ALASKA
RESOLUTION No. 03-18-1394

A RESOLUTION OF THE ASSEMBLY OF THE CITY & BOROUGH OF WRANGELL, ALASKA, APPROVING THE DISSOLVED AIR FLOTATION (DAF) SYSTEM AS THE SOLUTION FOR THE WATER TREATMENT PLANT CAPITAL IMPROVEMENT PROJECT AND ITS ASSOCIATED FUNDING PLAN

WHEREAS, the City and Borough of Wrangell operates a municipal water system that serves approximately 2,400 people, and;

WHEREAS, the selected construction Project is to construct a replacement surface water treatment plant using a Dissolved Air Flotation (DAF) with Multimedia Filtration treatment system, and;

WHEREAS, the proposed DAF water system will increase water treatment capacity and reliability to support existing water customers in Wrangell while encouraging growth. The improvements will help build a reliable water system that will supply the economy with a sustainable amount of water and provide adequate capacity for future development. This investment will help strengthen the local economy, support private capital investment and create jobs, and;

WHEREAS, the total cost of the Project is estimated at \$9,182,000, and;

WHEREAS, the Borough intends to finance the Project through a combination of loan and grant funds as follows:

Water Fund Contribution:	\$ 119,000
EDA Grant:	\$2,081,000
USDA Loan:	\$3,821,000
USDA Grant:	<u>\$3,161,000</u>
Total Project Funding	<u>\$9,182,000</u>

The local match funding for the EDA grant will be in the form of the loan from USDA in the amount of \$3,821,000 and its associated interim financing.

NOW, THEREFORE, BE IT RESOLVED BY THE ASSEMBLY OF THE CITY AND BOROUGH OF WRANGELL, ALASKA, that:

SECTION 1: The Dissolved Air Flotation (DAF) with Multimedia Filtration system is approved as the solution for the water treatment plant capital improvements project.

SECTION 2: The Assembly hereby authorizes the Borough Manager to negotiate and execute all agreements required for project loan and grant funds management. The Borough Manager is also authorized to execute subsequent amendments to said agreements to provide for adjustments to the project within the scope of services or tasks, based upon the needs of the project.

SECTION 3: The estimated cost of the entire project is \$9,182,000.

SECTION 4: The funding plan, which includes Water Fund contribution, EDA grant, USDA loan, and USDA grant is approved.

PASSED AND APPROVED BY THE ASSEMBLY OF THE CITY AND BOROUGH OF WRANGELL, ALASKA, this _____ day of March, 2018.

CITY AND BOROUGH OF WRANGELL, ALASKA

Dave L. Jack, Mayor

ATTEST:

Kim Lane, MMC, Borough Clerk

MEMORANDUM

TO: HONORABLE MAYOR AND MEMBERS OF THE ASSEMBLY
CITY AND BOROUGH OF WRANGELL

FROM: AMBER AL-HADDAD, DIRECTOR OF PUBLIC WORKS

SUBJECT: WATER TREATMENT IMPROVEMENTS, FINAL EVALUATION AND RECOMENDATIONS

DATE: January 29, 2018

INTRODUCTION

Wrangell's slow-sand water treatment facility experiences significant challenges in meeting peak water demand at various times of the year. Significant changes are needed to improve the facility's water treatment process to ensure compliance with water quality standards, to meet current peak demand, and to prepare for growth and the additional demand expected to be placed on the water system.

CBW Staff and Assembly have spent a significant amount of time and expense to assess the needs and identify alternatives for water treatment system improvements and maintenance. CRW Engineering Group joined the CBW to perform an engineering study to carefully evaluate various project delivery models and make a final recommendation to the CBW. This Memorandum summarizes the challenges of our current water treatment process, outlines the operations and maintenance, engineering and project funding work performed to date and provides staff's recommendations based on CRW's final evaluation and recommendations for further improvements to Wrangell's water treatment system.

BACKGROUND

To supply potable water, Wrangell owns and operates a Class 2 Public Water System (PWS ID No. AK2120143), under which the current water treatment plant was constructed in 1999 and features an ozonation process followed by roughing filter, slow-sand filtration and disinfection. Soon after the plant came on-line, the CBW became unable to operate a number of the processes in accordance with the design, which has resulted in less effective water treatment and higher than expected O&M costs. In addition, the facility struggles to meet peak water demand in the summer when seafood processors and cruise ships become active, as well as during the colder months when residents leave their water running to avoid freeze-up. Further, with high organic concentrations in the raw water, we are faced with high disinfection by-product formation when chlorine is injected in the plant's filtered water, prior to storage and distribution.

The current water treatment system is fed by a surface water source. In the process of producing drinking water, Wrangell deals with these primary challenges:

- Poor roughing filter performance.
- Premature head loss development in the slow sand filters, leading to difficulty and an inordinate frequency in filter maintenance.
- Average to below-average removal of organics from the water.
- Relatively high chlorine consumption in the distribution system.
- High levels of haloacetic acids in the distribution system.
- Low slow filtration capacity and water storage volume relative to summer and winter water demands.

The current filtration system is designed to remove organics through ozonation and filtration, prior to chlorination; however, the current design and consistent high flow volumes do not allow enough organics to be removed. Remaining high organics and turbidity cause rapid clogging of the sand filter; therefore, water is not filtered fast enough to meet the increased seasonal demand. The filters must be scraped and cleaned every week, rather than quarterly according to the plant's O&M design. This continual filter cleaning does not allow the necessary development of biofilm on the top layer of sand where the primary biological treatment should occur.

As required by the Safe Drinking Water Act and other State and Federal regulations, the CBW's treated water must meet certain water quality standards established by EPA. Based on stringent water quality regulations, it will become increasingly difficult to meet additional requirements for reducing the risk of health-related incidents in drinking water with our current treatment facility.

Demand within the community has grown and surpassed the design limits of the plant. The plant was designed for a peak flow of 900 gpm. Immediately following construction in 1999, this was found to be lacking in production capability and therefore the max production was increased to its current max production of 1,000 gpm, with little-to-no capability for additional production without modifications which would incur significant capital costs.

The increase in our seafood processing output and marine services industries has placed an increase in water consumption and added strain on the water plant. In July 2011 alone, our storage capacity fell to critical levels eight times, resulting in the potential shut down of seafood processors. As well, during the summers of 2014 and 2016, following the 2011 addition of a second 424,000 gallon treated water storage tank, the storage capacity level continued to reach critical levels. In July 2016 the treated water supply was at such critical low levels for several weeks that the City and Borough of Wrangell declared a Local Disaster and Emergency with a request for State assistance. The community was able to make it through these critical times only after one seafood processor redirected fish to another community, both processors made modifications to their processes, water sales to cruise ships were halted, water service to the

City's harbors and swimming pool was reduced, and mandated water conservation measures were implemented community-wide.

During 2016's critically low water supply period, Wrangell was already well into its first steps in the pursuit of an improved water treatment system. The CBW was engaged in performing a water plant pilot study with CRW Engineering Group, LLC. The purpose of that project was to identify deficiencies in our current water treatment plant, evaluate methods for improving the treatment process, perform on-site pilot testing of the alternative selected from the initial evaluation and provide guidance for the acquisition of recommended water treatment improvements. As the pilot plant testing was concluding, CRW developed a Preliminary Engineering Report to identify the findings of the pilot test and develop preliminary design criteria based on recommendations for Wrangell's Water Treatment Plant Improvements project.

TIMELINE OF WATER DEPARTMENT ACTIVITIES / PROJECT COSTS TO DATE

- June 2015 Assembly approves PSA to CRW Engineering with a contract to evaluate methods to improve its water treatment process and perform a pilot study. **(Project Cost \$158,112; \$150,000 funded from DCCED grant; \$8,112 funded from Water Department Reserves)**
- Feb 2016 Assembly accepts the CBW staff's and CRW's recommendation to implement the pilot study based on the preferred alternative testing method, using Dissolved Air Flotation (DAF) with Multi-media Filtration. This also allowed us the ability to compare the DAF alternative to the alternative to improve the existing facility based on the combined technical and economical merits toward meeting our community's water needs.
- July 2016 Treated water shortages, caused by high consumption, prompts Assembly to issue a Disaster Declaration and Request for State Assistance. Plea issued to community to reduce consumption between 30%-50%.
- July-Dec 2016 Staff consults with CRW to address water shortage issues/options, develop sand dredging cleaning methods, tracer study review, and prepare and review with DEC roughing filter improvements design based on media replacement. **(Project Cost: \$43,570; funded from Water Department Reserves)**
- Sept 2016 Assembly approves PSA amendment to CRW's pilot study contract to develop a Preliminary Engineering Report (PER) and Environmental Assessment (EA), a higher level of engineering report than originally required through the pilot plant project. The PER is required by USDA to qualify applicants for the USDA's WWD loan/grant program. **(Project Cost: \$64,098; funded from Water Department Reserves)**

- Oct 2016 CBW submits application to USDA's WWD program requesting funding for DAF treatment improvements.
- Dec 2016 CRW submits design of roughing filter modification, through media replacement and elevation, for ADEC review and approval.
- Jan 2017 CBW staff review CRW-recommended sand dredging plan, experiments with a dredge system and determines the dredge option to be ineffective. Staff begin developing an optional sand cleaning plan.
- Feb 2017 CBW and CRW review opportunities for value engineering to reduce overall capital costs of DAF replacement project. This effort resulted in a cost reduction of approximately \$3,000,000. The opportunity lost through this project scope and cost reduction is the water treatment capacity for projected community growth and that growth's associated water demands beyond the year 2038. Resulting DAF project cost is approximately \$9,000,000.
- March 2017 CBW receives ADEC-approval for roughing filter modifications based on media replacement and elevation of the media bed.
- March 2017 CBW submits final application to USDA requesting funding for DAF treatment upgrades.
- March 2017 Assembly approves expenditures of up to \$50,000 to make purchases and temporary hires, as necessary, to prepare for a successful upcoming peak water consumption season.
- April 2017 Water Shortage Management Plan adopted by Assembly.
- April 2017 Assembly approves contract to CRW to design roughing filter replacement with Forsta Filter's filtration system. ADEC approval received in June 2017. **(Projects Cost \$29,984; funded from Water Department Reserves)**
- April 26, 2017 Public hearing conducting for public review and comment regarding the Notice of Intent to File an Application to USDA for the purpose of financing improvements to Wrangell's water treatment system.
- April 2017 Water Department staff complete fabrication of a water/air scour plunging manifold and performed a trial run of first sand filter "plunging" for cleaning purposes with good success. Four temporary employees hired to assist with sand cleaning, in preparation of the coming peak summer season.

- April 2017 Assembly approves, and then reverses the approval, of \$250,000 for the replacement of media for one of the four sand filters.
- May 2017 At the Assembly's request, CRW provides opinion regarding efficiency of replacing only one sand filter's media in terms of filter flow rate and particulate loading rate. **(Project Cost: \$475; funded from Water Department Reserves)**
- May 2017 Two, new Ozone Generators installed **(Project Cost: \$211,360; funded from Water Department Reserves, with reimbursement expected from DEC loan in FY18. This cost is based on the purchase of one generator. The manufacturer offered to replace the generator unit that we purchased in 2016, with their newest series, at no additional cost to the CBW.)**
- June 2017 Ordinance 935 Water Chapter revised to increase water rates (7% in 2017; 5% in 2018 and 5% in 2019) for all customers and restructure the base-rate and bulk-rate water volumes for small and large commercial metered customers.
- June 2017 CBW receives ADEC approval to construct roughing filter modifications based on Forsta Filter design by CRW. Construction project cost estimated at \$250,000 for design based on two filters (one is for redundancy).
- June-July 2017 Staff consults with Case Marine regarding improvements to roughing filters. Suggestions included exploring a down-flow design with possible addition of air scouring system or the Forsta Filters, considering the requirement of a system that includes redundancy for efficient operation.
- July 2017 CBW receives notice from USDA of their agency's consideration to loan \$3,821,000 and grant \$3,161,000 for water treatment improvements based on DAF treatment upgrades and backwash waste disposal, pending receipt from the Borough of Form RD 1942-46, Letter of Intent to Meet Conditions, and Form RD 1940-1, Request for Obligation of Funds, required within thirty days of receipt of this notification.
- Aug 2017 Staff receive results of our water's particle count sampling, indicating that greater than 90% of particles would pass through the originally suggested 10-micron screen mesh. Based on this new information, CRW verified with Forsta Filter that six (not two) Forsta Filter units, with 5-micron screen mesh, are needed to adequately replace our existing roughing filters (three of the six, or half of the operational need, are for redundancy). Further design for this larger system has yet to be finalized, including ADEC's further follow-on concurrence.

- Sept 2017 Assembly approves PSA to Shannon & Wilson to conduct a Groundwater Desktop Study to investigate the probability of a groundwater source on Wrangell Island. **(Project Cost: \$8,055; funded from Water Department CIP)**
- Staff plan to include a copy of Shannon & Wilson's the Groundwater Desktop Study findings in the February 6, 2018 Assembly Agenda packet.
- Oct 2017 Consideration given to adding backwash options to both a roughing filter redesign similar to the plant's original up-flow design, but with elevated media to optimize the backwash process, as well as to a roughing filter redesign that provides a down-flow with backwash capabilities. These options are being reviewed with Roberts Filters' staff engineers who are reviewing our water characteristics, current design and have offered to make initial recommendations based on the filtration systems they design. The automatic self-cleaning Forsta Filters is also being reexamined based on the need of additional filters that was determined after receiving the particle count analysis information.
- CBW issues amendment to CRW's contract to further analyze water treatment improvement alternatives, including additional options for short-term improvements to the roughing filters, and to consider adding a water metering program geared toward water conservation efforts. **(Project Cost: \$15,750; funded from Water Department CIP)**
- Oct 2017 CBW performs sand media analysis to compare the existing properties of the sand to the specification of the sand as originally designed. The results from the tests were analyzed by CRW in their final evaluation and recommendation **(Project Cost: 1,300; funded from Water Department Facility Maintenance budget FY18)**
- Nov 2017 CBW receives USDA notice that the \$3,821,000 loan and the \$3,161,000 grant were officially approved in Federal Fiscal Year 2017 for the construction and upgrades to the water treatment plant to house two parallel DAF units and backwash waste disposal. This approval assumes the CBW's ability to contribute the remaining project cost through other funding sources. This approval requires a subsequent set of conditions be met to continue project momentum.
- Dec 2018 CBW receives CRW Engineer's draft evaluation and recommendation for review and comment. Schedules final submittal in January 2018.
- Jan 2018 CBW receives CRW Engineers' final evaluation and recommendation for water treatment improvements.

COST SUMMARY TO DATE

- Engineering-related costs from 2015-Present are \$321,344
- Ozone Generator costs in 2017 were \$211,360 (advanced from Water Department Reserves; to be reimbursed through receipt of ADEC-approved loan)
- Ozone Generator costs in 2016 were \$202,620 (fully funded from Water Department Reserves)

RECOMMENDATION

Given the updated information on the two alternatives, Alternative 1 - Improve Existing Water Treatment Process, and Alternative 2 – Dissolved Air Flotation (DAF) with Multimedia Filtration, staff recommend the following:

- A. Adopt Alternative 2 of the CRW Engineering Group, LLC's January 24, 2018 Memorandum entitled Water Treatment Upgrades: Final Evaluation and Recommendation and construct a new water treatment facility based on the DAF treatment process. Reason's supporting this recommendation:
1. The capital cost of the DAF project is substantially less, by approximately \$6.5 million, than the capital cost to make improvements to the existing treatment/process facility for providing similar capacities in both water treatment and water storage.
 2. Although the DAF alternative is projected to have slightly higher (approximately 5% higher) O&M costs (includes wages, chemicals and supplies, maintenance and operation of the treatment plant) than the alternative to improve the existing plant, the DAF alternative is the more cost effective treatment process based on having a lower life cycle cost and the higher treatment efficiency.
 3. The DAF project would result in less volume of water waste associated with backwashing.
 4. The DAF project is estimated to require less time for construction.
 5. DAF offers the more cost effective technology for meeting water demand for future growth. The modular design of the DAF system better facilitates future expansion as Wrangell continues to grow.
 6. DAF provides an almost instantaneous, and "on demand" supply of treated water as demand from the community dictates, versus the lengthy delay of the current, slow-sand system's treatment process.

7. DAF is expected to provide excellent color removal and good organics removal, thus reducing our current level of Disinfection By-Products (DBP) in the distribution system. DAF is a robust process that can accommodate significant variability in raw water quality without substantial adjustments in the treatment process.
8. Wrangell already enjoys quality water. The DAF treatment system will serve to improve the quality of Wrangell's drinking water.

A more detailed timeline for this recommendation will be provided subsequent to this Memorandum.

- B. For near-term improvements, move forward with the roughing filters' replacement based on the Forsta Filters' self-cleaning mechanical filters option. Replacing the roughing filters will provide significant improvements to the treatment process until a DAF project is fully implemented. Reason's supporting this recommendation:
 1. Replacing the existing roughing filters with the Forsta Filters, prior to DAF implementation, will provide Wrangell with significant gains and improvements to the treatment process, maintenance process, and final water quality during the interim period between now and DAF operation. Further benefits expected through this improvement are increased capacity of treated water, longer run times for the sand filters, and improved water quality.
 2. During construction of the DAF treatment system, a roughing filter replacement system would be required based on the fact that the conceptual design of the DAF system proposes to modify the roughing filter building in order to house the DAF units. The Forsta Filter units could be relocated during reconstruction of the roughing filter building to continue serving this pre-treatment process, a cost that would otherwise be incurred in the DAF project, Phase 1 (this interim pre-treatment filtration is currently not included in CRW's DAF project cost estimate, as it is recommended to be an expense incurred ahead of that project, as found in the recommendations).

While we are reasonably confident that the Forsta Filters will meet the needs of our pre-treatment filtration, as a replacement for the existing roughing filters, staff have moved forward with short-term pilot testing through the rental of a small Forsta Filter pilot filter, which will be installed for a couple of weeks to collect data.

This recommendation requires additional time for further design of the six-filter system and ADEC's follow-on review, prior to construction. The timeline to complete a Forsta Filter self-cleaning mechanical filters replacement project is not projected until after the summer peak season has begun; however, we would move swiftly to have the final design and agency concurrence completed without delay, with the hope that a

construction start might be possible during the summer. A more detailed timeline for this recommendation will be provided subsequent to this Memorandum.

- C. There is industry support that indicates a water metering program can play an important role in reducing water consumption. Such a program can also help to predict flows, determine leaks within the distribution system, set water rate structures for equitable cost allocation, and determine who to target for further conservation measures. While adding a water metering system in Wrangell could play a role in water conservation, due to the significant capital costs, of between \$3.4M - \$4.6M, for a program of this nature, staff do not recommend pursuing a Borough-wide metering project at this time.
- D. Continue pursuit of funding alternatives, including grants and loans, to pay for the water treatment system's improvements projects determined by final Assembly approval.

The Borough's water system must balance four major elements, those being supply, treatment, distribution and rates. In the big picture of balancing these elements, replacing the existing treatment system will improve our number-one, most-significant water challenge of today. While moving forward to construct a new water treatment facility will reduce the amount of funds available for future improvements to the dams and distribution system, Wrangell's ongoing water treatment system problem cannot continue to be pushed aside any longer. As we move forward, we will need to make improvements to other portions of our water system. Given the financial status of the Water Department, these further improvements are expected to cause increases to water rates if those projects are to be addressed.

FINANCIAL PLAN

The total cost of the recommended improvements is \$9,640,000 and is recommended to be paid through a combination of loans and grants.

<i>Source of Project Funds</i>	<i>Amount</i>	<i>For</i>	<i>Additional Annual Debt Service</i>
Borough Water Fund Reserves	458,000	Roughing Filters	0.00
USDA Grant Revenue	3,161,000	DAF Plant	0.00
USDA Loan Payable (Proceeds from Loan)	3,821,000	DAF Plant	153,189.78
EDA Grant Revenue	1,750,000	DAF Plant	0.00
DEC Loan Payable	450,000	DAF Plant	26,210.58
Total	9,640,000		179,400.36

Because it is not yet known, the above project costs do not include the interim financing cost required by USDA.

Staff is drafting projections for future budgets, which will include the additional debt service, as well as projected operations and maintenance (O&M) costs for the DAF system.

It is not currently recommended that the upcoming sequential 5% rate increases effective 7/1/2018 and 7/1/2019 be modified, however it is possible that subsequent rate increases will be recommended or required to cover the operating costs, debt service costs associated with these plant improvements, and other anticipated capital needs. It is recommended that a formal rate study be considered to assist in developing these longer-range rate recommendations, necessary to establish a cash reserve to repay debt. Staff recognize the hardship that increasing rates places on our customers and will continue to make management decisions based on this acute awareness.

FUTURE WATER SYSTEM CAPITAL NEEDS

- Rate Study
- Dams' Rehabilitation
- Water Main Replacement
- Water Metering - Phased
- Other Unplanned Projects

ATTACHMENTS

- MEMORANDUM from CRW Engineering Group LLC entitled Water Treatment Upgrades: Final Evaluation and Recommendation, dated January 24, 2018

The Borough Assembly will review and discuss the water treatment improvements recommendations provided herein during a workshop scheduled for February 5, 2018, 5:30-7:00 p.m. Due to this short time frame available to review this project, the full report will not be reviewed in detail at that meeting, but rather the recommendations will be highlighted during the meeting, to leave time for Q&A and discussion. CRW Engineers, Jon Hermon and Will Kemp, will also attend the workshop, by teleconference, to discuss their evaluation and recommendations.

At their regularly-scheduled meeting on February 27, 2017, it is expected that the Assembly will deliberate and take action for water treatment system improvements.



Memorandum

Date: January 24, 2018
To: Amber Al-Haddad, City and Borough of Wrangell
From: CRW Engineering Group, LLC
Project: Wrangell Water Treatment Plant
Project No: CRW #20901.00
Subject: Water Treatment Upgrades: Final Evaluation and Recommendation

1. Background

The City and Borough of Wrangell (CBW) has retained CRW Engineering Group, LLC (CRW) to provide engineering services related to improving the community's water treatment plant (WTP). The CBW currently operates a Community Public Water System (PWSID # AK2120143) using a surface water source under the requirements of the U.S. Environmental Protection Agency (EPA) surface water treatment rules. CRW prepared a Desktop Analysis in December 2015 and a Preliminary Engineering Report (PER) in April 2017, both of which identified dissolved air flotation (DAF) with multimedia filtration as the recommended alternative. This technology was pilot tested on-site during the fall of 2016.

Since these studies were performed, CBW has explored additional strategies for improving its ability to meet near-term peak summertime water demands. These strategies include the following options:

- Modifying the roughing filter media stratification and gradation to improve cleaning via down-flushing.
- Replacing the roughing filter media altogether with automated self-cleaning screen filters.
- Adding positive means to backwash the roughing filter media.
- Cleaning the slow sand filter media using mechanical and chemical methods.
- Installing flow meters on service lines as a way to encourage community-wide water conservation.

This technical memorandum summarizes the assessments of these additional options in context of improving CBW's capacity to treat and supply water, and in relation to funding being pursued in the present time. Significantly improving its plant throughput would help CBW meet its near-term water demands and possibly delay the need for more substantial improvements, such as reconfiguring the treatment scheme around a DAF process. In light of these considerations, this technical memorandum also further reviews which of the two previously short-listed alternatives that CBW may pursue as a long-term strategy to meet its growth and treatment objectives:

- Improve various processes of the existing WTP facilities.
- Implement DAF and multimedia as the principal water treatment processes.

Another important consideration in the review of these alternatives is the need for additional water storage, which would better buffer the water treatment process from extreme variations in community water demand. The need for additional water storage is evaluated further in this exercise as an option of both alternatives.

2. Funding Overview

The CBW anticipates funding treatment system upgrades through a combination of funding sources.

The CBW has accepted a funding package from the United States Department of Agriculture (USDA) comprised of a \$3,821,000 loan and a \$3,161,000 grant for a total amount of \$6,982,000. The scope of the funding package is based upon the recommendations outlined in the PER prepared by CRW which would upgrade the treatment system to a DAF treatment technology. The USDA funding can only be used for the scope outlined in the PER, and the funding package must be used within five years.

The CBW has also requested \$450,000 in funding from the Alaska Department of Environmental Conservation (ADEC) Drinking Water Fund priority list. The CBW plans to apply for \$1,500,000 in additional funding from the Alaska Economic Development Administration (EDA). Additionally the CBW has allocated \$250,000 in their Water Department Capital Improvements Projects (CIP) budget for improving the water treatment process.

3. Existing Water Treatment Process Concerns

The concerns expressed by CBW as significantly impacting the water treatment process are summarized in both the *Desktop Assessment* and *Preliminary Engineering Report* recently conducted to evaluate CBW's water treatment process. Concerns further addressed in this memorandum are summarized below.

- Roughing Filter Performance: CBW operators report that occasionally the turbidity leaving the roughing filters is greater than that entering the filters. This condition appears to be a symptom of poor cleaning performance by the backwashing system, which would result in the accumulation of contaminants within the media. These accumulations are occasionally discharged to the downstream slow sand filters in relatively high concentrations. These issues may be aggravated by the use of media particles that are larger than specified. Further, as the roughing filters gradually clog with captured solids while operating in an up-flow direction, the water surface upstream of these filters will tend to rise. Because the maximum rise that can be sustained without impacting the process flow through the ozone contactor is less than 2 feet, the length of the roughing filters run times is limited.
- Slow Sand Filter Cleaning: Although the slow sand filtration system design anticipated a cleaning frequency of about four times per year, the actual need to clean filters arises about every 10 to 14 days on average (more frequently with higher summer flows and less frequently with lower winter flows). This condition appears to be due to the slow sand filters being subjected to a higher-than-anticipated solids loading rate, since the roughing filters are not performing effectively. ADEC has also expressed concern that the ATV used in cleaning the filters could contaminate the water.
- Filtration Capacity: During summer months, when fish processors and other commercial users are consuming potable water, the water demand increases to the point where it is difficult to take filters off-line for cleaning. All filters are needed in these conditions to meet the peak water demand. Further, in a 2012 Sanitary Survey performed by ADEC, concern was expressed that the slow sand filters were not allowed to properly "ripen" (i.e., redevelop a sufficient biomat for effective treatment) prior to being placed back on-line. This requirement does not appear to be possible with the frequency currently needed for cleaning, nor for the WTP to function in peak demand conditions.

4. Water Treatment Upgrade Alternatives

a. Alternative 1 – Improve Existing Water Treatment Process

The existing water treatment process features slow sand filtration. Slow sand filtration primarily uses a biological process to remove biodegradable and assimilable substances, which are not readily removed by ordinary granular filtration methods. As water slowly flows through fine-grained sand media, a biological mat (“schmutzdecke”) develops on its surface, which provides a medium in which microbes can encounter, break down, and assimilate dissolved compounds.

Under this alternative, the existing slow sand filter treatment process would be upgraded. General flow capacity increases would be made to the existing unit processes including: pH adjustment, ozonation, roughing filtration, and slow sand filtration. A backwash clarifying tank and sludge storage area and secondary dewatering system would be installed for backwash water disposal.

In particular, the roughing filters would also be modified to provide the following upgrades:

- Media gradations revised to provide better filtering performance.
- Improved media cleaning capability.
- Increased upstream hydraulic head to better accommodate solids uptake in the roughing filters.

With these roughing filter improvements, it is believed that slow sand filter performance would be enhanced as well, allowing them to operate longer between cleanings and more readily enable filter cleaning and media ripening. However, because these improvements would be made to an existing, custom-designed filtration system, it is not certain precisely how much these upgrades would improve the performance of the overall filtration process.

b. Alternative 2 – Dissolved Air Flotation (DAF) with Multimedia Filtration

DAF is a pre-filtration process that uses the introduction of minute air bubbles to suspend low-density solids like algae and organic compounds, which facilitate the removal of these contaminants from the water treatment stream. These compounds are typically difficult to remove by sedimentation processes, because they settle very slowly, especially when water temperatures are colder. With sedimentation, coagulants are used to increase the mass of these compounds and increase their ability to settle out of the treatment flow and be disposed of. Further, the sedimentation process needs to operate with slower flow rates when water temperatures are relatively cold.

DAF is an effective alternative to sedimentation, as the targeted compounds are floated instead of settled, and are subsequently skimmed from the water surface. With the use of flotation, smaller coagulant dosages can be used to remove contaminants, because it is generally easier to float suspended particles out of the process flow rather than sinking them. With DAF providing a more efficient removal process, the required treatment time can be made considerably shorter than for the sedimentation process. Consequently, DAF flow rates are typically higher, and the equipment can be made smaller relative to conventional filtration.

Under Alternative 2, the existing roughing filter building would be expanded to house two parallel DAF plants installed downstream of the pH adjustment system. The two package plants would integrate DAF and multimedia filtration. PAX XL-19, an aluminum chlorohydrate, would be used

as the coagulant and rapid-mixed with the raw water. With this alternative, a lower dosage of alum would be used due to the efficiencies of DAF. This alternative would include reusing the existing disinfection system and converting the existing slow sand filters to a serpentine clearwell for storing treated water. A backwash clarifying tank and sludge storage area and secondary dewatering system would be installed onsite to treat backwash wastewater.

5. Near-Term Options for Alternative 1 Improvements

Several near-term options for improving the existing water treatment system were considered and are presented in the following sections, including roughing filter improvements, self-cleaning filters, and slow sand filter improvements.

a. Roughing Filter Cleaning Improvements

Three media cleaning sub-options were reviewed for the CBW roughing filters:

- Sub-option 1: Downflow backwashing with raised media bed.
- Sub-option 2: Provide air scour prior to down-flow backwashing with raised media bed.
- Sub-option 3: Provide simultaneous air scour and up-flow backwashing with media bed supported on basin bottom.

Sub-Option 1:

The media currently rests on the concrete floor of the roughing filter basin and operates in an up-flow configuration. The roughing filters are currently cleaned using a down-flow backwash. Backwashing is accomplished by a rapid drawdown of the water in the basin, which is intended to strip and flush solids from media particles. However, the actual drawdown is slow, due to the inability for water to exit the basin relatively quickly. Water outflow appears to be inhibited by the existing distributor piping at the basin bottom also being used as a backwash collector system.

To improve the down-flow cleaning process under this sub-option, the media would be raised up and supported on grating to provide an open space below. The grating would be supported by steel beams and concrete blocks. With an open space between the bottom layer of media and the concrete basin floor, the media cleaning process could be made more effective by promoting a faster drawdown that would better suspend and flush accumulated solids from the media. Additionally, three new, large drain valves would be installed to facilitate the rapid draining of the basin that is responsible for cleaning. The basin floor will be sloped as well to direct solids to the drains by gravity.

To accommodate the elevated media support grating, the depth of the existing coarse media would be reduced to 2 feet. The existing media would be overlain by a 1-foot layer of finer media with particle sizes ranging between 4 to 8 mm, to enhance solids removal during the filtering process.

This sub-option was initially developed by CBW and CRW as a relatively economical way to improve CBW's ability to clean the media consistent with the original design intentions. However, the uncertainty of how well this technique would work made questionable the costs to make the modifications. This sub-option was therefore not given further consideration.

Sub-Option 2:

The media and media supports would be reconfigured as described in the Sub-Option 1 section above, except that the media sizes would be reduced to range between 2.2 and 2.4 mm, and constitute the entire media depth. This depth is also increased from 36 to 42 inches. To more-positively clean the media, an air scour would be applied prior to the fast drawdown. The air scouring would be provided using a piped grid installed below the media. Air would be pumped into the grid using an air blower. As air bubbles are diffused through the media, they rise upward and agitate the media particles for a prescribed time period. To accommodate media expansion during the backwash process, it is assumed that the roughing filter walls would be extended to about 3 feet above the existing finish floor elevation.

Sub-Option 3:

If the direction of backwash flow were reversed to an upward direction, then an air scour could be applied simultaneously, which would agitate and more effectively clean the media. With relatively large media particles used in these filters, effective cleaning is currently impractical without air scour to supplement the backwash flow.

To backwash the filters in this fashion, a pump would be activated to increase the up-flow through the filter media. Air scouring would then be applied similar to the configuration described above for Sub-Option 2. After media agitation and scouring, the backflow up-flow would continue until a targeted clarity was achieved in the water. Then the backwash pump would be deactivated, and the WTP flow redirected to the slow sand filters. By cleaning solids upstream beforehand, the loading rate on the slow sand filters could be reduced, thereby allowing them to run longer.

For this sub-option, the media bed would be supported directly on the basin floor similar to the existing configuration, which would maintain the existing freeboard depth. Steel launder troughs would be installed at an elevation higher than the collector pipe inlets to receive backwash flow and direct it to waste.

Discussion of Roughing Filter Improvement Sub-Options

A number of considerations are needed for all of the roughing improvement sub-options presented above. The first is that the available hydraulic head at the roughing filter basin is limited for operating with a media range size of 4 to 8 mm, as originally designed. When the roughing filters were first put into operation, the media reportedly clogged rapidly, presumably due to the relatively small media size working with a high solids loading rate. Based on discussions with filter manufacturers, this condition was likely made worse by the limited upstream head, about 2 feet, which is the difference in water surface elevations between the ozone contactor and the roughing filters. As a result, the filters would've experienced significant backwater increases as the media progressively clogged with solids. The media has since been replaced with larger diameter pea gravel, but this gradation has marginal capability to filter solids. Further, any retained solids are prone to sloughing off media particles, which produces effluent water quality that is poorer than the influent water.

For any of the sub-options presented, additional hydraulic head would be needed with the design media gradation to provide effective filtration. Two options are apparent for increasing the hydraulic head, presuming that the roughing filter would continue to be operated in an up-flow fashion. The first option would be to add a set of booster pumps just upstream of the roughing filters, with associated piping, valves and controls. The second option would be to modify the ozone contactor and roughing filters to provide this hydraulic head, which would be accomplished

by increasing the height of the contactor and roughing filter concrete walls, and making any necessary adjustments to the WTP's existing automated flow control valve.

The other consideration associated with upgrading the existing roughing filters is the size of backwash pumps and blowers that would be required. Because the roughing filters have a low loading rate (1.15 GPM/SF), the size of the filters is relatively large relative to the process flow rate. As a result, the size of the blowers and backwash pumps required to effectively clean the filters would also be proportionally large in size.

It should be noted that for all of these sub-options and the roughing filter options described in Sections 5b and 5c below, existing valving and infrastructure would allow for bypassing the roughing filters during construction. Because the roughing filters do not significantly improve water quality to the sand filters, and often make it worse, bypassing the roughing filters during construction of either sub-option is not anticipated to be an issue.

b. Pre-Treatment with Self-Cleaning Filters

Another option would be to replace the existing roughing filters with self-cleaning mechanical filters. These mechanical filters would employ a two-stage screening process using a coarse screen followed by a fine screen. Screen sizes are selected based upon raw water characteristics. Correspondence with a self-cleaning filter manufacturer has indicated that a screen size of 10 microns is the appropriate size for CBW's raw water. The self-cleaning filters would use controlled backwash pumps to perform automated filter backwashes. A booster pump would also be required to provide sufficient flow and pressure through the self-cleaning filters. In order to facilitate maintenance and provide redundancy, two sets of self-cleaning filters, backwash pumps and booster pumps would be required. The self-cleaning filters and associated piping, pumps and valves could be installed in the roughing filter basins.

c. Pre-Treatment with Up-flow Clarifiers

Another option would be to replace the existing roughing filters with an up-flow clarifier. The media in the up-flow clarifiers would be designed to provide adequate pre-treatment before the slow sand filters and be washable. The primary advantage of using up-flow clarifiers is that the loading rate can be designed to be much higher than that currently used for the existing roughing filters. Consequently, the footprint of an up-flow clarifier would be a fraction of the roughing filter footprint. The up-flow clarifier would require a pressure pump on the upstream side to provide sufficient flow through the filter. Both the up-flow clarifier and the pressure pump could be located in the existing roughing filter basin, which would require removal of the existing roughing filter components. An air blower and backwash pump would also be required to provide air scour and simultaneous backwash. The blower would likely be located on the floor of the roughing filter building. The backwash pump would be located in the roughing filter basin. A filtration aid (coagulant) would also be used to improve filtration. The coagulant dosing system would be located in the control building.

d. Slow Sand Filter Improvements

To improve filter flow, CBW has been reviewing ways to rejuvenate the slow sand filters either by media replacement or by media cleaning. Since the media was originally installed in the late 1990s, captured solids have gradually accumulated in the deeper media zones. CBW can backwash the slow sand filters by opening a valve that conveys treated water from the WSTs and through the piped effluent collector system at the bottoms of the filter basins. The backwash

flow rate is limited by the fact that the collector system orifices are oriented downward. With this configuration, CBW is concerned that a high flow rate would irreversibly thrust the effluent collector system upward into the media. This piped system is not believed to be sufficiently tied to the filter floor such that it can be held down against the thrusting. Consequently, the backwash flow is throttled to avoid this damage, but the resulting flow rate is ineffective in cleaning the sand media.

Media replacement was reviewed and deemed to be prohibitively expensive, due to the large volume of sand needed and the shipping distances to manufacturers that produce NSF-certified sand. Just the cost of procuring the sand would amount to around \$850,000. The labor cost of transporting the media from the docks to the WTP and replacing the media in the four filters would add to the procurement cost.

To mechanically clean the media, the use of a hydraulic eductor was reviewed by CRW with CBW, which was successfully used in another filter improvement project. However, this method was complicated by the fact that CBW's existing slow sand media is layered in two specific particle sizes: 0.5 mm and 1.0 mm. The intent of this layering is understood to keep media from flowing out the effluent collector system, which is comprised of slotted piping. Concern was expressed that the eductor approach, which based its cleaning technique on substantial movement of the sand with water, was impractical without destroying this layering.

Nevertheless, CBW developed and employed a similar approach with the use of jets. The jets were comprised of pipe wands, through which water and air were pumped. By plunging the jets into the media depth, the sand could be agitated and solids materials could be drawn up to the media surface where it could be washed away. This method was used on all the filters. Although the sand layering was apparently not destroyed with this method, some localized disturbance has probably occurred at the layer interface. Nevertheless, negligible media loss has been observed, and as a result of these efforts, CBW has achieved significant improvements in filter flow rates. Whereas each filter was conveying a rough average of 150 to 200 GPM (about half the design capacity) prior to cleaning, after cleaning, they each are flowing around 300 to 350 GPM, with about the same freeboard water levels as before.

As part of the evaluation to rejuvenate the existing media in-place, CBW submitted slow sand filter corings to Blue Earth Products to analyze the sand gradation. Testing by Blue Earth confirmed that the media not within design specifications in terms of media size (see Table 1). Industry standards for slow sand filters recommend a media size of 0.15 to 0.3 mm, which is somewhat smaller than that used in rapid rate filtration.

Table 1 – Sand Design Criteria

Criteria	Design Specifications	2017 Testing
Uniformity Coefficient	<1.7 (AWWA)	1.54
Effective Size	0.15 -0.35 mm (AWWA)	0.5 mm

According to the test report by Blue Earth, the media also exhibited deposits of primarily iron, aluminum and calcium on the surface of the media. The report recommended chemically rejuvenating the media with Blue Earth's proprietary cleaning agent, a low-pH acidic solution, to

remove accumulated surficial deposits. CBW expressed interest in pursuing this application as a way to clean the media in-place, without disturbing the stratification of the two sizes of sand.

However, the application of this product on slow sand filters is questionable in a number of ways:

- Most of the treatment in slow sand filters typically occurs within the schmutzdecke and the top few inches of media. It is within this upper media zone that most of the pressure head is developed as solids are accumulated. Chemically cleaning the deeper media zone may not result in a significant improvement in filter flow rate relative to CBW's recent efforts in mechanically washing the media, and therefore may not be cost-effective.
- At the present time, this cleaning technology has not yet been used on slow sand filters, according to a company representative, and therefore no history of successful usage is available to guide its implementation at CBW's facility.
- Although the cleaning agent is NSF 60-listed, proper usage of this product requires a flushing step followed by a pH adjustment step. The pH adjustment chemical needs to be introduced in the filter-to-waste stream and be sufficiently mixed with the flush water for proper neutralization. Safe discharge to the environment would depend on sufficient neutralization. The WTP's inability to effectively backwash the slow sand filters introduces some risk in its ability to effectively flush the low pH cleaning agent and pH adjustment chemical from the filter beds. Further, plant modifications would be needed to introduce and mix the pH adjustment chemical.

Table 2 – Near Term Improvement Capital Costs

Description	Cost
Roughing Filter Improvements	\$683,000
Self Cleaning Filters	\$458,000
Upflow Clarifiers	\$461,000
Slow Sand Cleaning	\$203,000

6. Water Storage

CBW's current water storage volume is approximately 0.85 million gallons, as provided by two aboveground tanks of equal size. This volume is about equal to the current average daily water demand (ADD) and roughly half of the maximum daily water demand (MDD), and as such, is insufficient to supply the City's water supply needs. The inability to provide sufficient water volume impacts individual water consumers, medical facilities, seafood processing plants, and the ability to respond to local fires. Further, during periods of high water usage, the treatment process is directly exposed to the variation in water demand. In this condition, unit processes must keep pace with peaking demands, which often require that they operate at maximum capacity for long periods of time. This condition can severely reduce the time needed for CBW to perform maintenance and repairs on the unit processes that are most stressed. Also, an insufficient buffer between the water treatment process and the community water demand might reduce the available contact time for complete disinfection of the treated water.

CBW is prone to experiencing water shortage events, which are most pronounced during the summer season when water demand is highest. In July 2016, CBW passed a Disaster Declaration with Request for State Assistance due to inadequacy of the system to provide sufficient flow to meet community water consumption. CBW also requested that the public ration water use by 30% to 50% in an effort to decrease

overall water use. Much of this rationing was achieved by consumers making more efficient use of supplied water through reduced wasteful practices. With increased conservation, CBW was able to sustain the community's essential water needs in 2016. The peak water demands experienced in 2017 were not as severe as the previous year. The 2017 summer fishing season did not produce a large salmon catch and local canneries closed earlier as a result, thereby lowering the water usage relative to the 2016 season.

To provide at least the volume consumed in one day of MDD (1.8 million gallons per day), the existing water treatment system would need an additional 1 million gallons of water storage. By providing this additional water storage, the increased stored volume (1.8 million gallons) would not only meet the MDD, but also provide nearly 2 days of the ADD. In so doing, this larger storage capacity would:

- Provide more flexibility in achieving sufficient disinfection contact time during peak water system demands.
- Allow CBW additional time to address any system failures that would diminish or otherwise shut down WTP flow.
- Better accommodate system maintenance, such as taking filters off-line for cleaning.

It is important to note that an increase in water storage capacity is considered beneficial only with a corresponding increase in water treatment capacity, as described in either Alternative 1 or 2. Increasing the storage capacity alone will not adequately address CBW's summer water shortage concerns. The treatment capacity of the plant should be great enough that the amount of water storage could be replenished in a reasonable time period, which would vary depending on the patterns of community water usage. To keep pace with peak water consumption, the water treatment plant needs the ability to treat water at a rate that is at least equal to the MDD. If not, the stored water volume, no matter how large, would gradually become depleted if the water consumption continued to exceed the water treatment capacity. However, if the treatment rate could keep pace with maximum demand, the stored volume could be maintained during periods of high water use and be refilled faster thereafter. As CBW experiences prolonged periods of high water usage during the summer, the ability to maintain and replenish the stored water volume is essential to avoiding water shortages.

For the purpose of more directly comparing the costs of Alternative 1 to Alternative 2 with similar project benefits, it is assumed that Alternative 1 would provide an additional 1 million gallons of water storage tank constructed adjacent to the existing water storage tanks. This storage volume could be provided in one tank or two tanks depending on the site topography and which arrangement would provide the most cost effective site development. Under Alternative 2, the existing slow sand filters would be converted into clearwells, taking advantage of reusing existing infrastructure.

7. Alternative Comparison

A matrix of the advantages and disadvantages of the two alternatives is presented below.

	Alternative 1 – Improve Existing Treatment Process	Alternative 2 – Dissolved Air Flotation (DAF) with Multimedia Filtration
Advantages	<ul style="list-style-type: none"> • CBW is familiar with this water treatment process. • O&M costs would remain relatively low, primarily because a lesser need for chemicals relative to other alternatives. • CBW would continue the use of ozone, having recently invested significant funds to replace its aging ozone generators. • Improved process would require the lowest operator certification level (III). 	<ul style="list-style-type: none"> • DAF is a more cost effective treatment process based on having the lowest life cycle costs and highest treatment efficiency. • The use of DAF is expected to provide good organics removal and excellent color removal • DAF is a robust process that can accommodate significant variability in raw water quality without substantial adjustments in the treatment process. • Existing infrastructure will be reused and repurposed for water storage facilities
Disadvantages	<ul style="list-style-type: none"> • High capital costs, which will be more difficult to fund relative to other alternatives. • Unlike the other alternatives, which could make use of the slow sand filter basins as additional water storage, Alternative 1 will require construction an additional water storage tank. • Potential for continued difficulties in post-treatment high chlorine demands and in reducing disinfection by-products, as slow sand filtration has limited organic removal capabilities. 	<ul style="list-style-type: none"> • This process will likely require a Level IV certification.

Capital costs for the two alternatives are presented below, with Alternative 2 being substantially lower than Alternative 1, which would require significant site development construction for additional slow sand filters and water storage. For this cost comparison, 2 new slow sand filters are assumed to be added to the existing facility for a total of six filters. With clean sand media, each filter is designed to provide 300 GPM of capacity. At this unit rate, 5 filters would provide up to 1500 GPM or 2.2 MGD of treatment capacity, with a sixth filter offline for cleaning and ripening purposes.

Table 3 – Capital Cost Comparison

	Alt 1 – Improve Existing	Alt 2 – DAF + Filtration
Water Treatment Upgrades	\$10,903,000	\$8,322,000
Water Storage Upgrades	\$3,876,000	Included in Treatment Upgrades
Backwash Disposal	\$860,000	\$860,000
Total	\$15,639,000	\$9,182,000

8. Recommendation and Discussion

The capital cost for Alternative 1 is substantially higher than for Alternative 2 for providing similar capacities in treatment and water storage. Even with no water storage improvements included with it, Alternative 1 would still be higher in cost. Because the capital costs of constructing additional sand filters would be more expensive on a unit basis than adding DAF modules, Alternate 2 would offer the more cost effective technology for meeting a growing water demand into the distant future.

The pilot testing for the DAF that was conducted in 2016 confirmed the suitability of DAF as an effective treatment technology for CBW's water supply needs. The use of DAF is expected to provide good organics removal and excellent color removal during treatment. DAF is also a robust process that can accommodate significant variability in raw water quality without substantial adjustments in the treatment process.

Alternative 2 would re-use the existing facilities and repurpose the slow sand filter basins to cost-effectively provide extra water storage. When compared with Alternative 1, Alternative 2 requires a significantly smaller filtration footprint, which is a significant advantage given the steep topography and high capital cost associated with development at the WTP site. Furthermore, the modular design of the DAF system will facilitate future expansion as CBW continues to grow. For the long-term outlook, Alternative 2 – DAF with Multimedia Filtration is therefore recommended as CBW's preferred alternative.

If CBW receives the funding current being pursued, it could implement the design and construction of one of the near-term options to more immediately address the WTP's capacity problems. However, because increased water storage is needed, the near-term improvements to the existing system would be considered a temporary stop-gap measure until the Alternative 2 improvements are completed. If community water conservation efforts were continued, and if design and construction of the Alternative 2 improvements were to be completed by 2021 (assuming one year of design in 2018-2019 and two years of facility construction in 2019-2021), the near-term improvements to the existing system may not be necessary. If Alternative 2 funding cannot be completely executed within the next two to three years (i.e. matching funding and loans secured), implementation of the preferred near-term option should be strongly considered.

Of the various near-term options that could enhance the performance of the roughing filters (and accordingly the slow sand filters), the self-cleaning filter or up-flow clarifier options would be the most cost-effective. Between these two, it is anticipated that the self-cleaning filter option would impose less complexity, as a polymer system would not be used to enhance solids removal. Being the most cost-effective, we believe the self-cleaning filter option would be the preferred option. The construction of this option could be accomplished within a year's time, but not likely before the 2018 peak water demand

season. It is recommended that this option be validated in pilot testing prior to proceeding with full scale construction.

9. Phasing Approach for Alternative 2

In order to facilitate greater flexibility with funding sources and construction scheduling, a phased approach for construction of the water treatment upgrades is presented. The components directly associated with the water treatment process would be installed during phase 1 and the supporting components would be installed in phase 2. Note that a two phase approach will result in a slight increase in overall construction cost as it will require two separate mobilization/demobilization efforts.

- | <u>Phase 1</u> | <u>Phase 2</u> |
|---|--|
| <ul style="list-style-type: none"> • Site work • Expand roughing filter building • DAF treatment system • Connections to existing system • Chemical feed, transfer and booster pumps • Control panels | <ul style="list-style-type: none"> • Conversion of filters to clearwells • Demolish ozone generation system • Remodel control building for chemical storage • Replace onsite chlorine generation system • Caustic feed system improvements • Standby generator and fuel system |

Capital costs for the recommended alternative - Alternative 2 –DAF with Multimedia Filtration are presented below.

Table 4 – Phased DAF Capital Costs

Description	WTP Upgrades (Phase 1)	Backwash Disposal (Phase 1)	WTP Upgrades (Phase 2)
Construction	\$6,104,000	\$715,000	\$828,000
Design	\$550,000	\$65,000	\$75,000
Construction Administration	\$550,000	\$65,000	\$75,000
Project Administration	\$123,000	\$15,000	\$17,000
Total	\$7,327,000	\$860,000	\$995,000
	Combined Total (Phase 1 + Phase 2)		\$9,182,000

10. Additional Considerations - Water Conservation and Water Service Meters

As discussed in the PER, the average per capita water use is approximately 250 gallons per capita-day (GPCD). Compared with other communities in Alaska of similar size, this is a relatively high per capita use rate. As residential service lines are not metered, it is not known how much of this volume is attributable to system water losses (pipeline leaks, water wasting at plant and hydrants, and others). Any efforts by CBW to identify leaks, exercise conservation measures or otherwise reduce water use will result in decreased system O&M costs and increased overall system efficiency.

One approach that municipalities have taken to reduce water consumption and encourage conservation is to install meters on water services. Meters on water services can not only reduce overall consumption, but with meters having sufficient accuracy at low flow rates, utilities can also better identify low-flow leaks in the distribution system. When meters are used, customers are typically billed by the gallon, rather than by a flat rate, and this method tends to inhibit indiscriminate water usage by consumers. Industry experience has shown that, when combined with an effective billing structure, metering can reduce water use by an average of 15% to 20%. This range may appear to be diminished somewhat by unmetered water losses and consumption. Further, these percentages can vary significantly beyond the average, depending on actual water usage and other local conditions.

Currently, services to major water users in the community, such as canneries and harbor users, are provided with flow meters. Further meter-related reductions in water usage would therefore be expected to substantially come from new installations in the remaining community. Assuming that a 20% water use reduction could be realized in 10 years of phased meter installations (approximately 100 per year), this would equate to a reduction in ADD of about 143,000 gallons per day at that time of complete build-out. This calculation also assumes 10 years of water use growth from the year 2014, consistent with the estimate provided in the *Desktop Assessment*. This reduced water usage would equate to about 33% of the capacity of one slow sand filter and therefore would not be expected to significantly reduce the need for additional, future slow sand filter capacity.

Flow Meter Technologies

Generally speaking, water service meters fall into two broad categories: non-automated meters and automated meters (or smart meters).

Non-Automated Meters

As the name implies, non-automated meters do not transmit data. These meters must be manually read on a periodic basis to monitor water use. Where the meter is located (i.e., at the curb stop, or within customers' houses) will impact the amount of labor expended to read the meter. Meters used in cold weather regions are usually located in warm enclosures.

Automated Meters

There are two main categories of automated meter systems: automatic meter reading (AMR) and advanced metering infrastructure (AMI). While the two terms are sometimes used interchangeably, they are in fact very different. AMR uses mobile data collection which, for instance, might employ a utility truck with a data receiver that drives through a neighborhood and collects meter data as it drives by each house. For AMR, data is typically collected on a monthly basis. AMI, on the other hand, uses a network of transmitters to send meter data to a central collection point on a continuous, real-time basis.

Table 6 – Water Meter Technology Comparisons

	Advantages	Disadvantages
Non-automated meters	<ul style="list-style-type: none"> • Low capital cost • Simplest approach, no receiving or transmitting equipment required 	<ul style="list-style-type: none"> • Meter reading requires technician to visually inspect each meter which can be labor intensive • Limited data, meters are typically read on a monthly basis
Automated meters (AMR)	<ul style="list-style-type: none"> • Doesn't require technician to visually inspect meter, meter reading can be done remotely. 	<ul style="list-style-type: none"> • Limited data, meters are typically read on a monthly basis
Automated meters (AMI)	<ul style="list-style-type: none"> • Meters are continuously monitored, provided continuous real-time data • Leaks can be identified on a real-time basis • The utility can actively engage with customers to provide feedback on water use, potential leaks or abnormal water usage patterns • Optimizes revenue by improving meter accuracy and identifying meter tampering or service theft 	<ul style="list-style-type: none"> • Smaller utilities can be challenged with the AMI system which requires IT personnel and equipment • An AMI system generates large volumes of data that must be managed • AMI systems can be tied to a particular vendor • High capital cost

Cost Discussion

The capital cost for installing the three different water meter systems are presented below. The cost estimates assume:

- Installation of 1,016 meters.
- Meter installation will be within residences and businesses either in crawlspaces or mechanical rooms/plumbing areas.
- Existing curb stops will be used to isolate water services.
- Primary service line material is copper.

The meter installation costs are presented as budgetary allowances, with limited on-site data available. In order to present a more accurate cost estimate, detailed information regarding each water service and associated building would be required.

Table 6 – Water Meter Capital Costs

Description	Cost
Water Meters (non-automated)	\$3,425,000
Water Meters (AMR)	\$3,631,000
Water Meters (AMI)	\$4,625,000

According to the *Preliminary Engineering Report*, the average annual treatment O&M cost is \$186,000. Assuming a reduction in water use of 15% this could equate to a potential savings in treatment O&M costs of \$27,900. Realistically, some of the O&M costs are "fixed" (i.e., would not decrease based on a decrease in water production), so the actual cost reduction may be less than indicated. However, even with a conservative cost savings of \$27,900, the simple payback period for the lowest cost non-automated meter option would still be nearly 100 years. Any additional increases or decreases in distribution system O&M costs might somewhat vary the payback return, but the order of magnitude would be still a very long time. Therefore, metering is not considered an economically viable option.

Attachments:

Cost Estimates (12 pages)

Figures (6 sheets)

Conceptual Capital Cost Estimate

1/24/2018

Roughing Filter Upgrades

ACTIVITY	NOTES	QUANTITY	UNIT	UNIT COST	TOTAL COST
Rouging filter basin demolition		1	ls	\$15,000	\$15,000
Roughing filter modifications - material only		1	ls	\$270,000	\$270,000
Roughing filter modifications - shipping and installation costs		1	ls	\$81,000	\$81,000
Ozone contactor and roughing filter wall increase (concrete)		30	CY	\$1,300	\$39,000
Ozone contactor and roughing filter hydraulic modifications		1	ls	\$25,000	\$25,000
				Subtotal	\$430,000
				Estimating Contingency 25.0%	\$108,000
				Inflation 3.5%	\$16,000
				Construction Subtotal	\$554,000
				Design 12.0%	\$67,000
				Construction Administration 9.0%	\$50,000
				City Administration 2.0%	\$12,000
				Estimated Total Cost	\$683,000

Conceptual Capital Cost Estimate

1/24/2018

Forsta Filters

ACTIVITY	NOTES	QUANTITY	UNIT	UNIT COST	TOTAL COST
Demolition		LS	1	\$15,000	\$15,000
Concrete		CY	13	\$1,200	\$15,600
Filter Housing		EA	6	\$18,000	\$108,000
Pressure Pump		EA	2	\$10,000	\$20,000
Backwash Pump		EA	2	\$10,000	\$20,000
Piping & Valves		LS	1	\$45,000	\$45,000
Back Pressure Valve		EA	2	\$10,000	\$20,000
Ladder		LS	1	\$6,000	\$6,000
Controls/Electrical		LS	1	\$80,000	\$80,000
				Subtotal	\$330,000
			Estimating Contingency	20.0%	\$66,000
			Inflation	3.5%	\$12,000
				Construction Subtotal	\$408,000
			Construction Administration	10.0%	\$41,000
			City Administration	2.0%	\$9,000
				Estimated Total Cost	\$458,000

Conceptual Capital Cost Estimate

1/24/2018

Upflow Clarifier

ACTIVITY	NOTES	QUANTITY	UNIT	UNIT COST	TOTAL COST
Rouging filter basin demolition		1	ls	\$15,000	\$15,000
Upflow clarifier - material only		1	ls	\$200,000	\$200,000
Upflow clarifier - shipping and installation costs		1	ls	\$60,000	\$60,000
Roughing filter hydraulic modifications		1	ls	\$15,000	\$15,000
Subtotal					\$290,000
Estimating Contingency 25.0%					\$73,000
Inflation 3.5%					\$11,000
Construction Subtotal					\$374,000
Design 12.0%					\$45,000
Construction Administration 9.0%					\$34,000
City Administration 2.0%					\$8,000
Estimated Total Cost					\$461,000

Conceptual Capital Cost Estimate

1/24/2018

Slow Sand Cleaning

ACTIVITY	NOTES	QUANTITY	UNIT	UNIT COST	TOTAL COST
Cleaning Chemicals		1	ls	\$65,000	\$65,000
Neutralization Chemicals		1	ls	\$32,000	\$32,000
Chemical Shipping		20	tons	\$700	\$14,000
Support Equipment (dosing, neutralization, discharge)		1	ls	\$30,000	\$30,000

Subtotal \$141,000

Estimating Contingency 25.0% \$36,000

Inflation 3.5% \$5,000

Construction Subtotal \$182,000

Engineering Support 9.0% \$17,000

City Administration 2.0% \$4,000

Estimated Total Cost \$203,000

Conceptual Capital Cost Estimate

1/24/2018

Water Meters

ACTIVITY	NOTES	QUANTITY	UNIT	UNIT COST	TOTAL COST
Positive Displacement Meters	Budgetary Allowance	1	Is	\$2,220,000	\$2,220,000
Subtotal					\$2,220,000
Estimating Contingency 25.0%					\$555,000
Inflation 3.5%					\$78,000
Construction Subtotal					\$2,853,000
Design 9.0%					\$257,000
Construction Administration 9.0%					\$257,000
City Administration 2.0%					\$58,000
Estimated Total Cost					\$3,425,000

ACTIVITY	NOTES	QUANTITY	UNIT	UNIT COST	TOTAL COST
Positive Displacement Meters with Automatic Meter Reading (AMR)	Budgetary Allowance	1	Is	\$2,340,000	\$2,340,000
Subtotal					\$2,340,000
Estimating Contingency 25.0%					\$555,000
Inflation 3.5%					\$78,000
Construction Subtotal					\$2,973,000
Design 12.0%					\$343,000
Construction Administration 9.0%					\$257,000
City Administration 2.0%					\$58,000
Estimated Total Cost					\$3,631,000

ACTIVITY	NOTES	QUANTITY	UNIT	UNIT COST	TOTAL COST
Positive Displacement Meters with Advanced Metering Infrastructure (AMI)	Budgetary Allowance	1	Is	\$3,420,000	\$3,420,000
Subtotal					\$3,420,000
Estimating Contingency 25.0%					\$555,000
Inflation 3.5%					\$78,000
Construction Subtotal					\$4,053,000
Design 9.0%					\$257,000
Construction Administration 9.0%					\$257,000
City Administration 2.0%					\$58,000
Estimated Total Cost					\$4,625,000

Conceptual Capital Cost Estimate

1/24/2018

Alternative 1 - Additional 1 MG Water Storage Tank

Project Duration

4 weeks

ACTIVITY	NOTES	QUANTITY	UNIT	UNIT COST	TOTAL COST
<u>General</u>					
Per Diem		224	day	\$60	\$13,440
Superintendent		4	weeks	\$7,200	\$28,800
Project Manager	8 hrs/week	4	weeks	\$800	\$3,200
Expeditor	40 hrs/week	4	weeks	\$2,800	\$11,200
Roundtrip Air Fare		3	each	\$1,000	\$3,000
Allowance for Misc Air Freight		1	ls	\$25,000	\$25,000
Survey		1	ls	\$15,000	\$15,000
Erosion Control		1	ls	\$10,000	\$10,000
Equipment Mobilization		1	ls	\$50,000	\$50,000
<u>Meetings/Coordination</u>					
Project Meetings		8	hours		\$800
Project Schedule		1	months	\$200	\$200
Shop Drawings		16	hours		\$1,600
<u>Equipment</u>					
Pickup (2 each)	Rental/Ownership Cost	4	weeks	\$300	\$1,200
Flatbed Truck	Rental/Ownership Cost	4	weeks	\$500	\$2,000
Note: Heavy Equipment Cost Included in Unit Costs for WTP Upgrades					
<u>Other</u>					
Project Office	Office + equipment	1	months	\$750	\$750
Safety Equipment		1	ls	\$5,000	\$5,000
Temporary Power	Generators for Tools	1	months	\$500	\$500
Hand tools, consumables, signage, porta cans, etc.		1	ls	\$35,000	\$35,000
Fuel, oil and gas for equipment		1	months	\$1,500	\$1,500
<u>Housing</u>					
Housing		1	months	\$10,000	\$10,000
Utilities		1	months	\$1,500	\$1,500
<u>Insurance</u>					
Certified Payroll Fee		1	ls	\$5,000	\$5,000
<u>Water Treatment Plant Modifications</u>					
Clearing and Grubbing		0.4	ACRE	\$10,000	\$3,587
Fill		1700	CY	\$35	\$59,500
Site Grading and Drainage		1	LS	\$50,000	\$50,000
Bedrock Blasting and Removal		2900	CY	\$80	\$232,000
Water Storage Tank and Insulation Package		1,000,000	gal	\$1.75	\$1,750,000
<u>System Startup, Operator Training and O&M Manuals</u>					
		1	ls	\$15,000	\$15,000
<u>Project Closeout</u>					
Punchlist Items		1	ls	\$5,000	\$5,000

Conceptual Capital Cost Estimate

1/24/2018

Asbuilts of System		1	ls	\$5,000	\$5,000
Site Cleanup		1	ls	\$5,000	\$5,000
Demobilization		1	ls	\$15,000	\$15,000

Subtotal \$2,365,000

General Contractor Overhead and Profit 15.0% \$355,000

 General Contractor Bond & Insurance 3.0% \$71,000

 Estimating Contingency 15.0% \$355,000

 Inflation 3.5% \$83,000

 Construction Subt \$3,229,000

 Design 9.0% \$291,000

 Construction Administration 9.0% \$291,000

 City Administration 2.0% \$65,000

Estimated Total Cost (Alternative No. 1) \$3,876,000

Conceptual Capital Cost Estimate

1/24/2018

Alternative No. 1 - Expand Existing Slow Sand Filtration System

Project Duration

52 weeks

ACTIVITY	NOTES	QUANTITY	UNIT	UNIT COST	TOTAL COST
<u>General</u>					
Per Diem		2912	day	\$60	\$174,720
Superintendent		52	weeks	\$7,200	\$374,400
Project Manager	8 hrs/week	52	weeks	\$800	\$41,600
Expeditor	40 hrs/week	52	weeks	\$2,800	\$145,600
Roundtrip Air Fare		35	each	\$1,000	\$35,000
Allowance for Misc Air Freight		1	ls	\$100,000	\$100,000
Survey		1	ls	\$25,000	\$25,000
Erosion Control		1	ls	\$10,000	\$10,000
Equipment Mobilization		1	ls	\$50,000	\$50,000
<u>Meetings/Coordination</u>					
Project Meetings		104	hours		\$10,400
Project Schedule		13	months	\$200	\$2,600
Shop Drawings		208	hours		\$20,800
<u>Equipment</u>					
Pickup (2 each)	Rental/Ownership Cost	52	weeks	\$300	\$15,600
Flatbed Truck	Rental/Ownership Cost	52	weeks	\$500	\$26,000
Note: Heavy Equipment Cost Included in Unit Costs for WTP Upgrades					
<u>Other</u>					
Project Office	Office + equipment	13	months	\$750	\$9,750
Safety Equipment		1	ls	\$5,000	\$5,000
Temporary Power	Generators for Tools	13	months	\$500	\$6,500
Hand tools, consumables, signage, porta cans, etc.		1	ls	\$35,000	\$35,000
Fuel, oil and gas for equipment		12	months	\$1,500	\$18,000
<u>Housing</u>					
Housing		12	months	\$10,000	\$120,000
Utilities		12	months	\$1,500	\$18,000
<u>Insurance</u>					
Certified Payroll Fee		1	ls	\$5,000	\$5,000
<u>Water Treatment Plant Modifications</u>					
Clearing and Grubbing		0.5	ACRE	\$10,000	\$5,000
Fill		3000	CY	\$35	\$105,000
Site Grading and Drainage		1	LS	\$125,000	\$125,000
Cleaning Existing Filter Sand		1	LS	\$50	\$50
Addition of (2) Slow Sand Filters					
Bedrock Blasting and Removal		1100	CY	\$80	\$88,000
Concrete Filter Beds		460	CY	\$1,300	\$598,000
Filter Piping		528	LF	\$120	\$63,360
Filter Valves, Fittings, Etc.		1	LS	\$32,000	\$32,000
Connection to Existing System		1	LS	\$30,000	\$30,000
Media for Filters		8400	CF	\$7	\$58,800

Conceptual Capital Cost Estimate

1/24/2018

Freight for Media		535	TONS	\$700	\$374,220
Metal Building Over Filters		2096	SF	\$250	\$524,081
Addition of (2) Roughing Filter					
Bedrock Blasting and Removal		1000	CY	\$80	\$80,000
Concrete Filter Beds		180	CY	\$1,300	\$234,000
Filter Piping		500	LF	\$120	\$60,000
Filter Valves, Fittings, Etc.		1	LS	\$45,000	\$45,000
Connection to Existing System		1	LS	\$20,000	\$20,000
Media for Filters		4320	CF	\$7	\$30,240
1 ft GAC Cap		2160	CF	\$35	\$75,600
20 hp Backwash Pumps		2	EA	\$35,000	\$70,000
Freight for Media		270	TONS	\$700	\$189,000
Metal Building Over Filters		1080	SF	\$250	\$270,000
Chemical Feed System		1	ea	\$35,000	\$35,000
Replace Onsite Chlorine Generation System		1	LS	\$115,000	\$115,000
Caustic Feed System Improvements		1	ea	\$30,000	\$30,000
Air Scour System		1	LS	\$150,000	\$150,000
Oxygen Generator		1	EA	\$210,000	\$210,000
Ozone Destructor		1	EA	\$50,000	\$50,000
Expansion of Ozone Contactor by 50%					
Bedrock Blasting and Removal		300	CY	\$80	\$24,000
Concrete Contact Filter		20	CY	\$1,300	\$26,000
Connection to Existing System		1	LS	\$15,000	\$15,000
60 hp Booster Pumps		2	ea	\$20,000	\$40,000
150,000-gal Recaptured Water Storage Tank		150000	gal	\$2.50	\$375,000
150,000-gal Tank Insulation Package		150000	gal	\$0.50	\$75,000
10 hp Transfer Pumps		2	ea	\$10,000	\$20,000
Recapture Water Piping		200	LF	\$120	\$24,000
Sand Removal System		1	LS	\$200,000	\$200,000
Sand Cleaning System		1	LS	\$400,000	\$400,000
Standby Generator		1	LS	\$150,000	\$150,000
Fuel System		1	LS	\$24,000	\$24,000
Control Panels		1	LS	\$200,000	\$200,000
System Startup, Operator Training and O&M Manuals					
		1	ls	\$50,000	\$50,000
Project Closeout					
Punchlist Items		1	ls	\$25,000	\$25,000
Asbuilts of System		1	ls	\$15,000	\$15,000
Site Cleanup		1	ls	\$25,000	\$25,000
Demobilization		1	ls	\$50,000	\$50,000

Subtotal \$6,654,000

General Contractor Overhead and Profit	15.0%	\$999,000
General Contractor Bond & Insurance	3.0%	\$200,000
Estimating Contingency	15.0%	\$999,000
Inflation	3.5%	\$233,000
Construction Subt		\$9,085,000
Design	9.0%	\$818,000

Conceptual Capital Cost Estimate

1/24/2018

Construction Administration	9.0%	\$818,000
City Administration	2.0%	\$182,000
Estimated Total Cost (Alternative No. 1)		\$10,903,000

Conceptual Capital Cost Estimate

1/24/2018

Alternative No. 2 - Dissolved Air Flotation with Multimedia Filtration

Project Duration

36 weeks (Phase 1)

4 weeks (Phase 2)

ACTIVITY	NOTES	QUANTITY	UNIT	UNIT COST	TOTAL COST (PHASE 1)	QUANTITY	UNIT	UNIT COST	TOTAL COST (PHASE 1)
General									
Meals and lodging		2016	day	\$60	\$120,960	224	day	\$60	\$13,440
Superintendent		36	weeks	\$7,200	\$259,200	4	weeks	\$7,200	\$28,800
Project Manager	8 hrs/week	36	weeks	\$800	\$28,800	4	weeks	\$800	\$3,200
Expeditor	40 hrs/week	36	weeks	\$2,800	\$100,800	4	weeks	\$2,800	\$11,200
Roundtrip Air Fare		24	each	\$1,000	\$24,000	3	each	\$1,000	\$3,000
Allowance for Misc Air Freight		1	ls	\$75,000	\$75,000	1	ls	\$25,000	\$25,000
Equipment Mobilization		1	ls	\$50,000	\$50,000	1	ls	\$10,000	\$10,000
Meetings/Coordination									
Project Meetings		72	hours	\$100	\$7,200	8	hours	\$100	\$800
Project Schedule		9	months	\$200	\$1,800	1	months	\$200	\$200
Shop Drawings		144	hours	\$100	\$14,400	16	hours	\$100	\$1,600
Equipment									
Pickup (2 each)	Rental/Ownership Cost	36	weeks	\$300	\$10,800	4	weeks	\$300	\$1,200
Flatbed Truck	Rental/Ownership Cost	36	weeks	\$500	\$18,000	4	weeks	\$500	\$2,000
Other									
Project Office	Office + equipment	9	months	\$750	\$6,750	1	months	\$750	\$750
Safety Equipment		1	ls	\$5,000	\$5,000	1	ls	\$5,000	\$5,000
Temporary Power	Generators for Tools	9	months	\$500	\$4,500	1	months	\$500	\$500
Hand tools, consumables, signage, porta cans, etc.		1	ls	\$30,000	\$30,000	1	ls	\$7,500	\$7,500
Fuel, oil and gas for equipment		9	months	\$1,500	\$13,500	1	months	\$1,500	\$1,500
Housing									
Housing		9	months	\$10,000	\$90,000	1	months	\$10,000	\$10,000
Utilities		9	months	\$1,500	\$13,500	1	months	\$1,500	\$1,500
Insurance									
Certified Payroll Fee		1	ls	\$5,000	\$5,000	1	ls	\$1,000	\$1,000
Water Treatment Plant Modifications - Phase 1									
Bedrock Blasting and Removal		1400	CY	\$80	\$112,000				
Site Grading and Drainage		1	LS	\$25,000	\$25,000				
Remodel Roughing Filter Bldg		1936	SF	\$50	\$96,800				
Expand Roughing Filter Bldg		2640	SF	\$325	\$858,000				
DAF Treatment System		1	LS	\$1,360,000	\$1,360,000				
Streaming Current Detector		1	ea	\$25,000	\$25,000				
Connection to Existing WTP Piping		1	LS	\$50,000	\$50,000				
Process Piping and Instrumentation		1	LS	\$350,000	\$350,000				
Chemical Feed Systems		1	LS	\$35,000	\$35,000				
10 hp Transfer Pumpst to Treatment System		2	ea	\$12,000	\$24,000				
60 hp Booster Pumps		2	ea	\$20,000	\$40,000				
Control Panels		1	LS	\$150,000	\$150,000				
Water Treatment Plant Modifications - Phase 2									
Conversion of Filters to Clearwells						4	ea	\$25,000	\$100,000
Demolish Ozone Generation System						1	LS	\$10,000	\$10,000
Remodel Part of Control Bldg for Chemical Storage						400	SF	\$50	\$20,000
Replace Onsite Chlorine Generation System						1	LS	\$115,000	\$115,000
Caustic Feed System Improvements						1	ea	\$30,000	\$30,000
Standby Generator						1	LS	\$150,000	\$150,000
Fuel System						1	LS	\$24,000	\$24,000
Temporary Water Treatment Facilities									
		1	ls	\$300,000	\$300,000				
System Startup, Operator Training and O&M Manuals									
		1	ls	\$50,000	\$50,000	1	ls	\$5,000	\$5,000
Project Closeout									
Punchlist Items		1	ls	\$25,000	\$25,000	1	ls	\$5,000	\$5,000
Asbuilts of System		1	ls	\$15,000	\$15,000	1	ls	\$2,500	\$2,500
Site Cleanup		1	ls	\$25,000	\$25,000	1	ls	\$5,000	\$5,000
Demobilization		1	ls	\$50,000	\$50,000	1	ls	\$10,000	\$10,000

Conceptual Capital Cost Estimate

1/24/2018

	Subtotal	\$4,470,000	Subtotal	\$605,000
General Contractor Overhead and Profit	15.0%	\$671,000		\$91,000
General Contractor Bond & Insurance	3.0%	\$135,000		\$19,000
Estimating Contingency	15.0%	\$671,000		\$91,000
Inflation	3.5%	\$157,000		\$22,000
Construction Subtotal		\$6,104,000		\$828,000
Design	9.0%	\$550,000		\$75,000
Construction Administration	9.0%	\$550,000		\$75,000
City Administration	2.0%	\$123,000		\$17,000
Estimated Total Cost (Alternative No. 4)		\$7,327,000		\$995,000
Combined Phase 1 + Phase 2 Total		\$8,322,000		

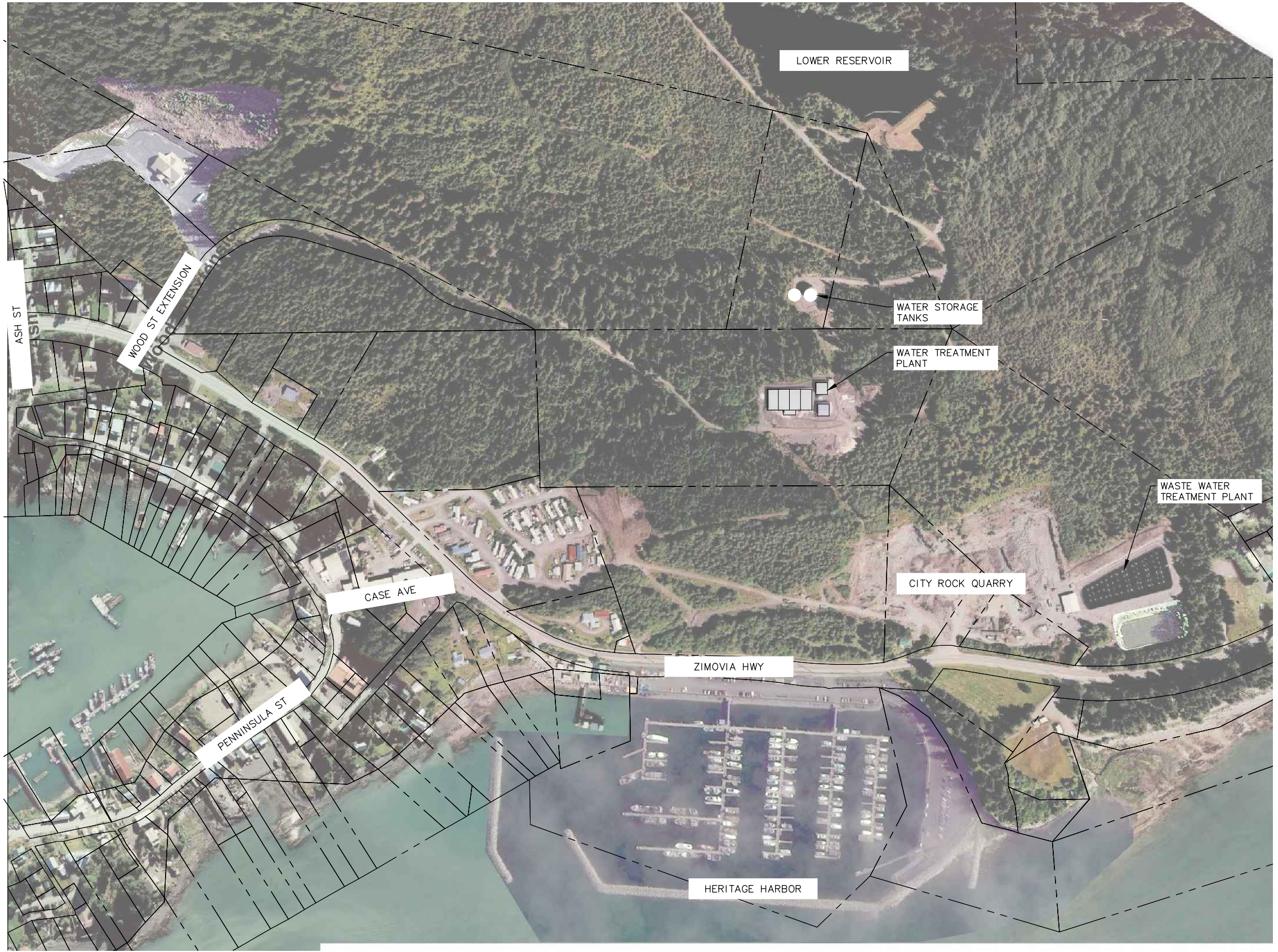

PROJECT: 20901.00
 STATUS: FINAL



WRANGELL WTP TECH MEMO
 EXISTING AREA MAP

DATE
10/24/17
 SCALE
GRAPHIC
 FIGURE
1



NEW 1,000,000 GALLON WATER STORAGE TANK

EXISTING WATER STORAGE TANKS

TREATMENT SYSTEM EXPANSION, SEE FIGURE 3

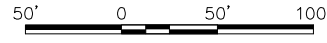

PROJECT: 20901.00
STATUS: FINAL



WRANGELL WTP TECH MEMO
1 MG WATER STORAGE TANK ALTERNATIVE 1

DATE	1/24/18
SCALE	GRAPHIC
FIGURE	2

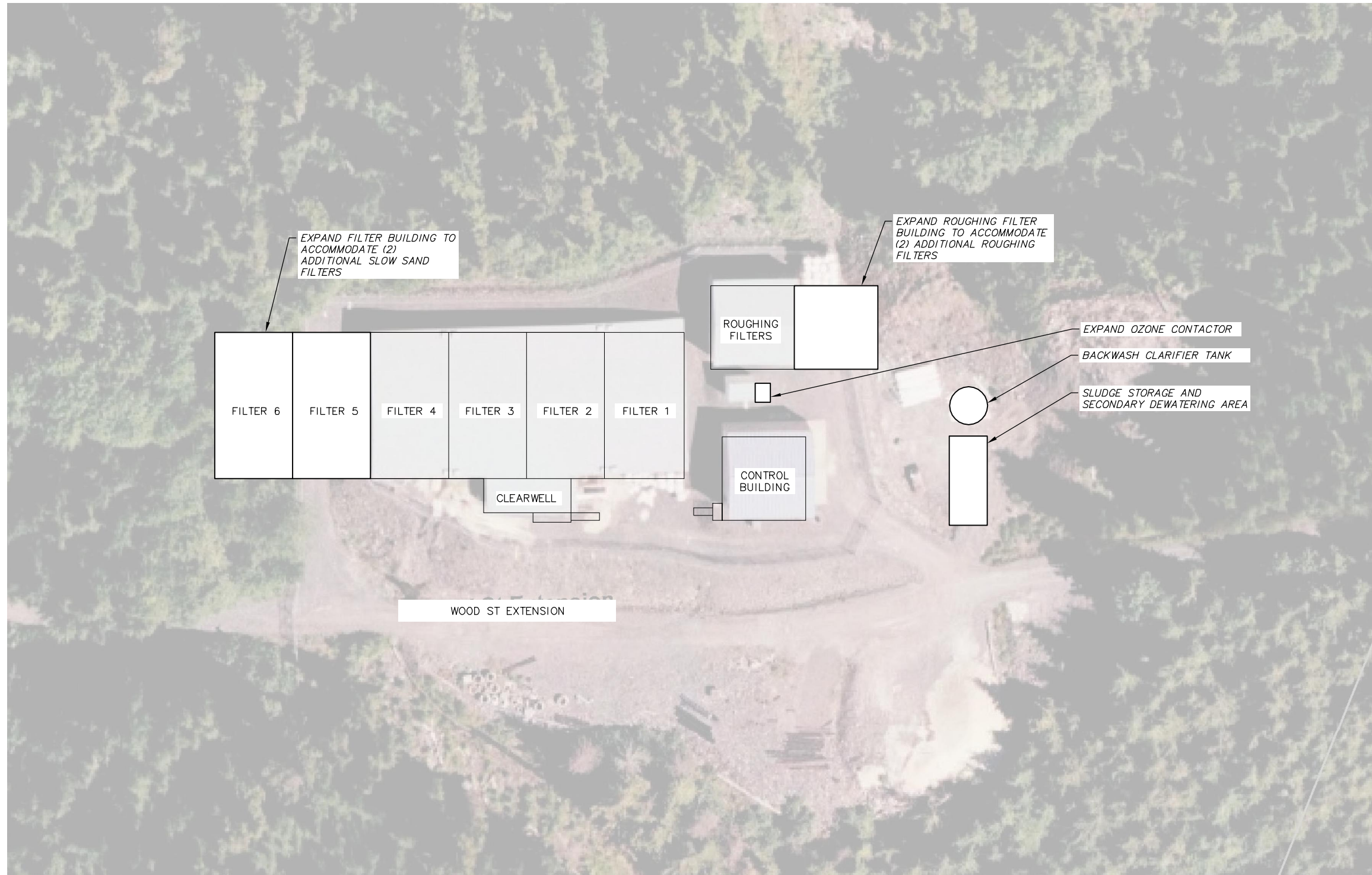

PROJECT: 20901.00
STATUS: FINAL



WRANGELL WTP TECH MEMO
SITE PLAN - ALTERNATIVE 1
IMPROVE EXISTING WATER
TREATMENT PROCESS

DATE	12/19/17
SCALE	GRAPHIC
FIGURE	3

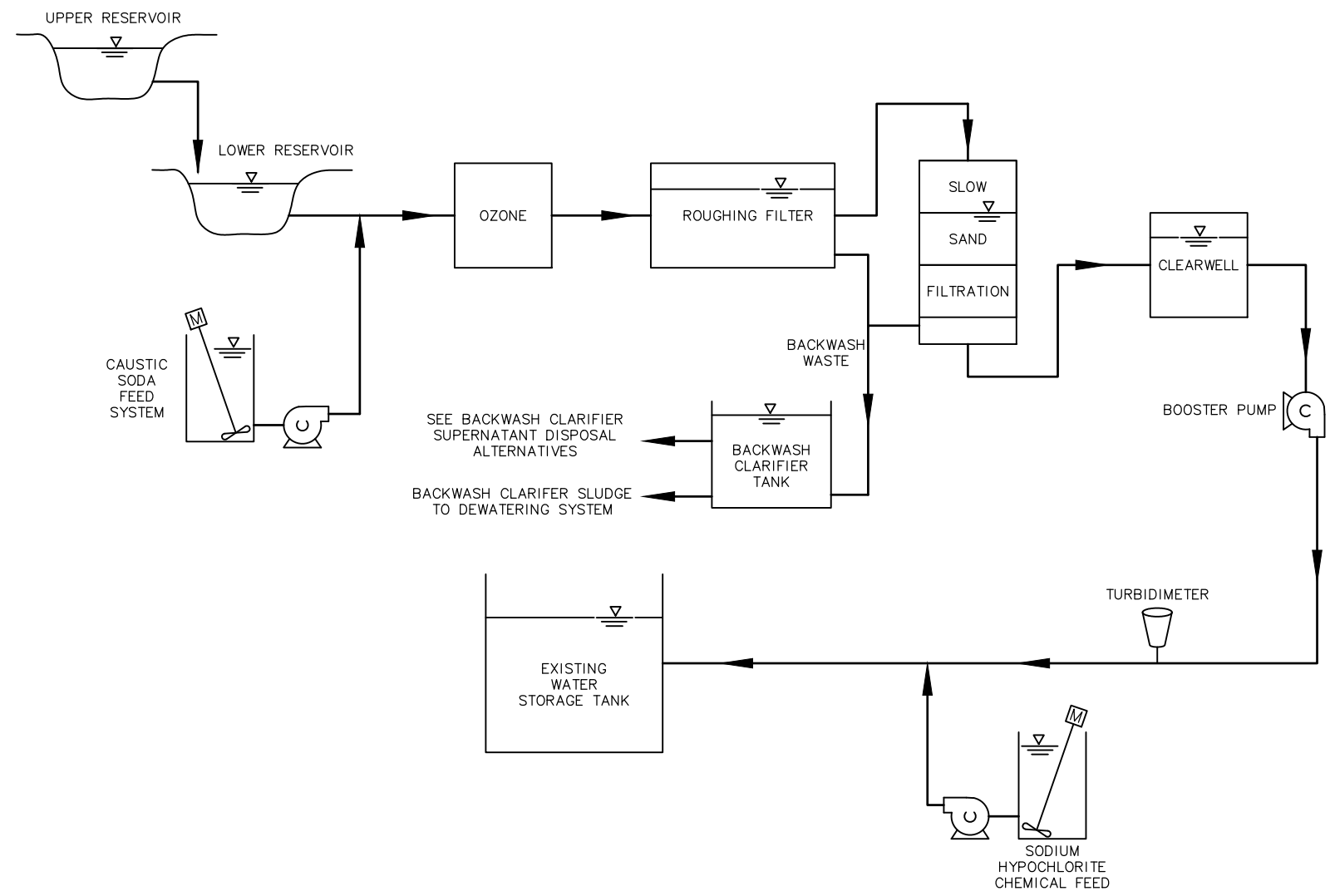

PROJECT: 20901.00
STATUS: FINAL



WRANGELL WTP TECH MEMO
PROCESS SCHEMATIC – ALTERNATIVE 1
IMPROVE EXISTING WATER TREATMENT
PROCESS

DATE
10/24/17
SCALE
GRAPHIC
FIGURE
4

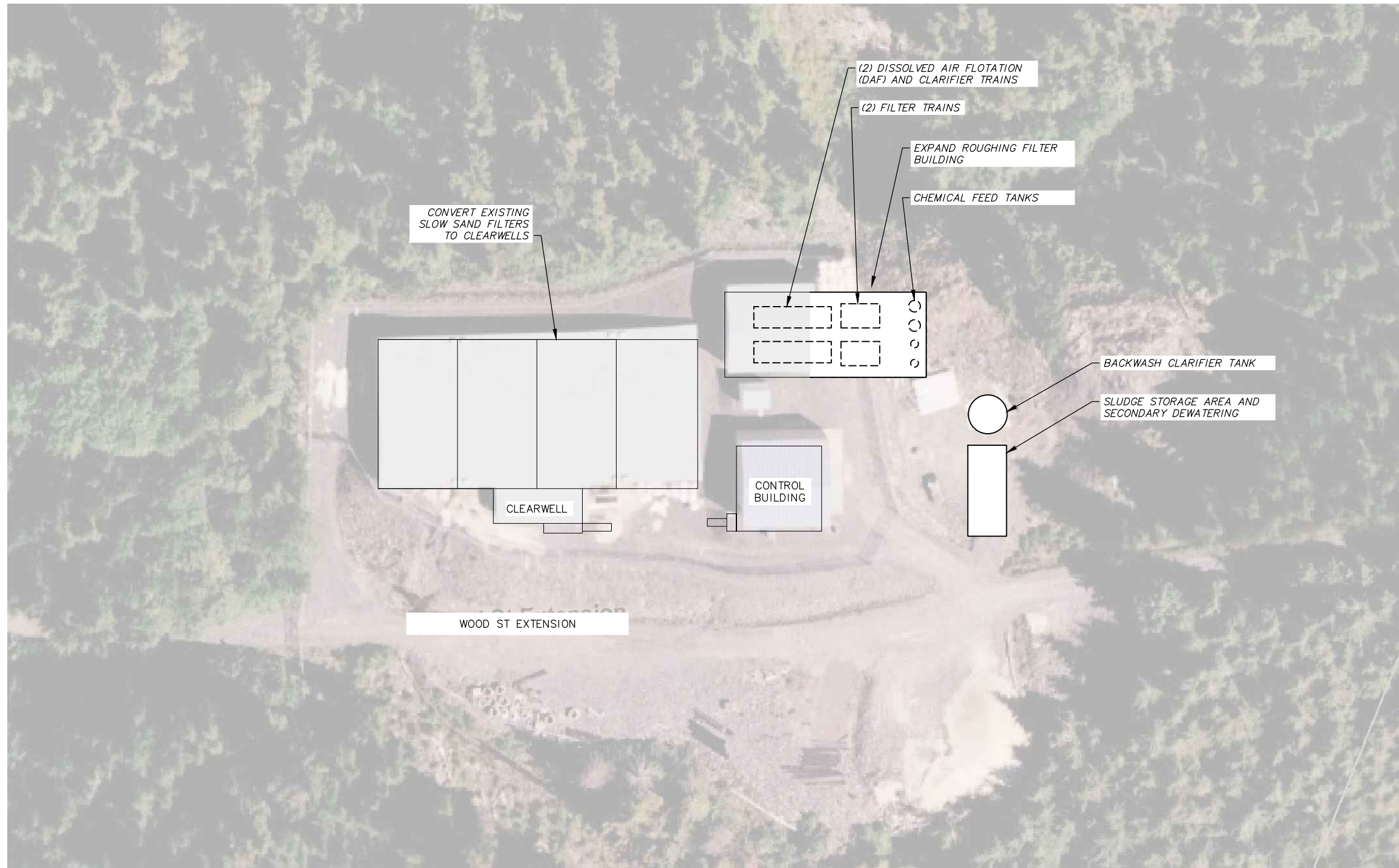

PROJECT: 20901.00
 STATUS: FINAL



WRANGELL WTP TECH MEMO
 SITE PLAN – ALTERNATIVE 2
 DISSOLVED AIR FILTRATION WITH
 MULTIMEDIA FILTRATION

DATE
10/24/17
 SCALE
GRAPHIC
 FIGURE
5

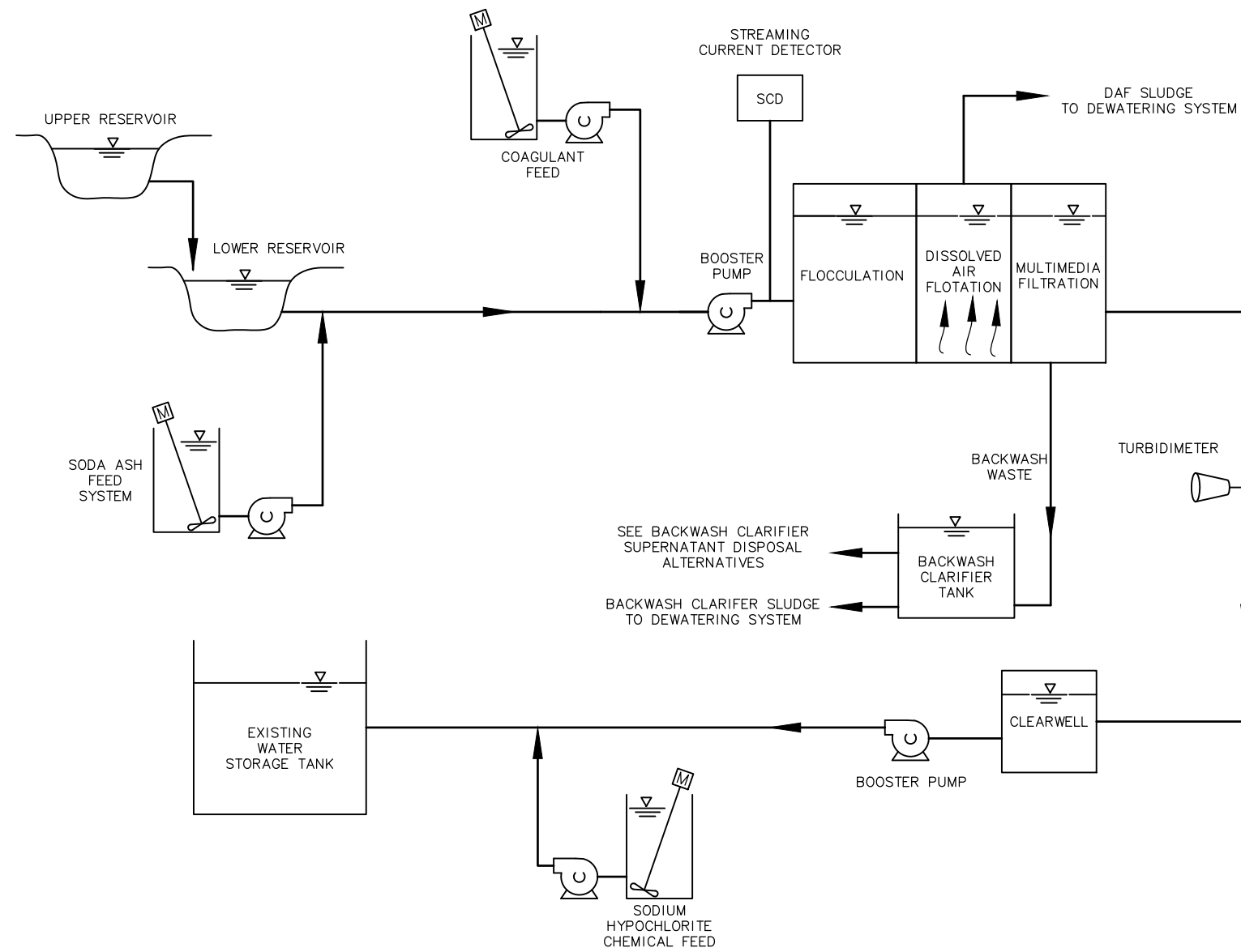

PROJECT: 20901.00
STATUS: FINAL



WRANGELL WTP TECH MEMO
PROCESS SCHEMATIC – ALTERNATIVE 2
DISSOLVED AIR FLOTATION AND
MULTIMEDIA FILTRATION

DATE
10/24/17
SCALE
GRAPHIC
FIGURE
6