

CITY AND BOROUGH OF WRANGELL



REID STREET SIDEWALK REPLACEMENT PROJECT MANUAL

June 2022

SECTION 00005 - TABLE OF CONTENTS

DIVISION 0 - BIDDING AND CONTRACT REQUIREMENTS, CONTRACT FORMS, AND CONDITIONS OF THE CONTRACT

BIDDING AND CONTRACT REQUIREMENTS No. of Pages

00005	Table of Contents	1
00030	Notice Inviting Bids	2
00100	Instructions to Bidders	8
00300	Bid	3
00310	Bid Schedule	1
00320	Bid Bond	1
00360	Subcontractor Report	2

CONTRACT FORMS

00500	Agreement	7
00610	Performance Bond	2
00620	Payment Bond	2

CONDITIONS OF THE CONTRACT

00700	General Conditions	47
00800	Supplementary General Conditions	3
00830	Alaska Labor Standards, Reporting & Prevailing Wage Rate Determination	1

DIVISION 1 - GENERAL REQUIREMENTS

01010	Summary of Work	4
01025	Measurement and Payment	3
01045	Cutting and Patching	3
01400	Quality Control	2
01505	Mobilization	1
01700	Project Closeout	1
01704	Final Clean-up and Site Restoration	1

DIVISION 2 – SITE WORK

02204	Base Course	3
02220	Demolition	2

DIVISION 3 – CONCRETE

03301	Concrete Paving	6
-------	-----------------------	---

DIVISION 5 – METAL

05520	Handrails and Railings	4
-------	------------------------------	---

DRAWINGS

Drawings Sheets 1-5	5
---------------------------	---

END OF SECTION

SECTION 00030 - NOTICE INVITING BIDS

OBTAINING CONTRACT DOCUMENTS. The Contract Documents are entitled:

REID STREET SIDEWALK REPLACEMENT

Notice is hereby given that the City and Borough of Wrangell, Alaska will receive sealed bids for the construction of the **REID STREET SIDEWALK REPLACEMENT** project.

The Contract Documents may be downloaded free of charge on the City & Borough of Wrangell (CBW) website (www.wrangell.com) under the Bids and RFPs section. Downloading Contract Documents from the City & Borough of Wrangell's website requires registration with the Borough Clerk to be placed on the Plan Holders List and to ensure receipt of subsequent Addenda. Failure to register may adversely affect your proposal. It is the Offeror's responsibility to ensure that they have received all Addenda affecting this Solicitation. To be registered, contact the Borough Clerk at 907-874-2381; Borough Clerks Office, 205 Brueger Street, Wrangell, Alaska 99929; or at clerk@wrangell.com.

DESCRIPTION OF WORK. The Work consists of all activities necessary to construct the Reid Street Sidewalk Replacement project, including asphalt cutting, concrete and guardrail demolition and disposal, excavation, base course, concrete paving, and metal guardrail installation. The Owner's estimate for the project is approximately \$55,000.

SITE OF WORK. The WORK is located along Reid Street behind the Community Center in Wrangell, Alaska.

COMPLETION OF WORK. The OWNER will open the work site to the CONTRACTOR immediately upon issuing a Notice to Proceed. Substantial completion must be reached by August 19, 2022.

BIDDING, CONTRACT, or TECHNICAL QUESTIONS. All communications relative to this WORK, prior to opening Bids, shall be directed to the following:

Amber Al-Haddad
Capital Facilities Director
Telephone: (907) 874-3902
Email: aal-haddad@wrangell.com

BID SECURITY. Each bid shall be accompanied by a bid bond, cashier's check or certified check made payable to the City and Borough of Wrangell in the amount of five percent (5%) of the total bid price. This serves as a guarantee that the Bidder, if its Bid is accepted, will promptly execute the Agreement. A Bid shall not be considered unless one of the forms of Bidder's security is enclosed with it.

RECEIPT OF BIDS. Sealed bids will be received by the City and Borough of Wrangell, Post Office Box 531, Wrangell, Alaska 99929, located at the Borough Clerk's Office, 205 Brueger Street, Wrangell, Alaska 99929, until **2:00 PM prevailing time on July 6, 2022**, at which time they shall be opened and read aloud. Opening date and time may be changed to a later date or time via Addendum. Clearly mark on the outside of the envelope "**Sealed Bid for REID STREET SIDEWALK REPLACEMENT.**"

SUBCONTRACTORS. The apparent low Bidder is required to complete and submit the following documentation within five (5) calendar days following the posting of bids by the City and Borough of Wrangell:

- Section 00360 - Subcontractor Report.

SECTION 00030 - NOTICE INVITING BIDS

CONTRACTOR'S LICENSE. All contractors are required to have a current Alaska Contractor's License, prior to submitting a Bid, and a current Alaska Business License prior to award of the bid.

BID TO REMAIN OPEN. The Bidder shall guarantee the Bid for a period of sixty (60) days from the date of Bid opening. Any component of the Bid including additive alternates may be awarded anytime during the 60 Days.

OWNER'S RIGHTS RESERVED. The OWNER reserves the right to reject any or all Bids, to waive any informality in a Bid, and to make award to the lowest responsive, responsible Bidder as it may best serve the interests of the OWNER.

OWNER: The City and Borough of Wrangell

By: _____ Date _____
Jeff Good, Borough Manager

END OF SECTION

SECTION 00100 - INSTRUCTIONS TO BIDDERS

1.0 DEFINED TERMS. Terms used in these “Instructions to Bidders” and the “Notice Inviting Bids” which are defined in the General Conditions have the meanings assigned to them in the General Conditions. The term “Bidder” means one who submits a Bid directly to the OWNER, as distinct from a sub-bidder, who submits a Bid to a Bidder.

2.0 INTERPRETATIONS AND ADDENDA.

A. **INTERPRETATIONS.** All questions about the meaning or intent of the Contract Documents are to be directed to the ENGINEER. Interpretations or clarifications considered necessary by the ENGINEER in response to such questions will be issued by Addendum and emailed to all parties recorded by the OWNER as having received the Contract Documents. Questions received less than 7 Days prior to the date for opening of Bids may not be answered. Only questions answered by formal written Addendum will be binding. Oral and other interpretations or clarifications will be without legal effect.

B. **ADDENDA.** Addenda may be issued to modify the Contract Documents as deemed advisable by the OWNER. The OWNER may issue addenda by fax, with a follow-up addendum copy issued by regular mail. Addenda may be emailed less than 7 Days prior to the anticipated Bid opening. The OWNER will make reasonable attempts to provide addenda; however, it is strongly recommended by the OWNER that Bidders independently confirm the contents, number, and dates of each Addenda prior to submitting a Bid. All Bidders who submit a bid shall be deemed to have received and reviewed all addenda.

3.0 FAIR COMPETITION. More than one Bid from an individual, firm, partnership, corporation, or association under the same or different names will not be considered. If the OWNER believes that any Bidder is interested in more than one Bid for the WORK contemplated, all Bids in which such Bidder is interested will be rejected. If the OWNER believes that collusion exists among the Bidders, all Bids will be rejected.

4.0 RESPONSIBLE BIDDER. Only responsive Bids from responsible Bidders will be considered. A Bid submitted by a Bidder determined to be not responsible may be rejected. A responsible Bidder is one who is considered to be capable of performing the WORK.

A. The general standards for responsibility are to determine the CONTRACTOR’s ability to perform WORK adequately, considering the CONTRACTOR’s

1. Financial Resources
2. Ability to Meet Delivery Standards
3. Past Performance Record
 - a. References from others on CONTRACTOR’s performance
 - b. Record of performance on prior OWNER contracts
4. Record of Integrity
5. Obligations to OWNER
 - a. Bidders must be registered as required by law and in good standing for all amounts owed to the OWNER within 5 Days of OWNER’s Notice of Intent to Award.

SECTION 00100 - INSTRUCTIONS TO BIDDERS

- B. Special standards for responsibility, if applicable, will be specified. These special standards establish minimum standards or experience required for a responsible Bidder on a specific contract.
- C. Before a Bid is considered for award, a Bidder may be requested to submit information documenting its ability and competency to perform the WORK, according to general standards of responsibility and any special standards which may apply. It is Bidder's responsibility to submit sufficient, relevant, and adequate information. OWNER will make its determination of responsibility and has no obligation to request clarification or supplementary information.

5.0 RESPONSIVE BIDS. Only responsive Bids will be considered. Bids may be considered non-responsive and may be rejected. Some of the reasons a Bid may be rejected for being non-responsive are:

- A. If the Bid is on a form other than that furnished by the OWNER, or legible copies thereof; or if the form is altered or any part thereof is detached; or if the Bid is improperly signed.
- B. If there are unauthorized additions, conditional or alternate bids, or irregularities of any kind which may tend to make the proposal incomplete, indefinite, or ambiguous as to its meaning.
- C. If the Bidder adds any unauthorized conditions, limitations, or provisions reserving the right to accept or reject any award, or to enter into a contract pursuant to an award. This does not exclude a Bid limiting the maximum gross amount of awards acceptable to any one Bidder at any one bid opening, provided that any selection of awards will be made by the OWNER.
- D. If the Bid does not contain a unit price for each pay item listed, except in the case of authorized alternate pay items.
- E. If the Bidder has not acknowledged receipt of each Addendum.
- F. If the Bidder fails to furnish an acceptable Bid Guaranty with the Bid.
- G. If any of the unit prices bid are excessively unbalanced (either above or below the amount of a reasonable Bid) to the potential detriment of the OWNER.
- H. If a bid does not conform to Articles 15.0 and 16.0 of this Section.

6.0 BIDDER'S EXAMINATION OF CONTRACT DOCUMENTS AND SITE. It is the responsibility of each Bidder before submitting a Bid:

- A. To examine thoroughly the Contract Documents, and other related data identified in the bidding documents (including "technical data" referred to below):
 - 1. To visit the site to become familiar with and to satisfy the Bidder as to the general and local conditions that may affect cost, progress, or performance of the WORK;

SECTION 00100 - INSTRUCTIONS TO BIDDERS

2. To consider federal, state and local laws and regulations that may affect cost, progress, or performance of the WORK;
3. To study and carefully correlate the Bidder's observations with the Contract Documents, and other related data; and
4. To notify the ENGINEER of all conflicts, errors, or discrepancies in or between the Contract Documents and such other related data.

7.0 REFERENCE IS MADE TO THE SUPPLEMENTARY GENERAL CONDITIONS FOR IDENTIFICATION OF:

- A. Those reports of explorations and tests of subsurface conditions at the site which have been utilized by the Engineer of Record in the preparation of the Contract Documents. The Bidder may rely upon the accuracy of the technical data contained in such reports; however, the interpretation of such technical data is the responsibility of the Bidder.
- B. Those drawings of physical conditions in or relating to existing surface and subsurface conditions (except underground utilities) which are at, or contiguous to, the site have been utilized by the Engineer of Record in the preparation of the Contract Documents. The Bidder may rely upon the accuracy of the technical data contained in such drawings; however, the interpretation of such technical data is the responsibility of the Bidder.
- C. Copies of such reports and drawings will be made available by the OWNER to any Bidder on request if said reports and drawings are not bound herein. Those reports and drawings are not part of the Contract Documents, but the technical data contained therein upon which the Bidder is entitled to rely, as provided in Paragraph SGC-4.2 of the Supplementary General Conditions, are incorporated herein by reference.
- D. Information and data reflected in the Contract Documents with respect to underground utilities at or contiguous to the site is based upon information and data furnished to the OWNER and the Engineer of Record by the owners of such underground utilities or others, and the OWNER and ENGINEER do not assume responsibility for the accuracy or completeness thereof unless it is expressly provided otherwise in the Supplementary General Conditions, or in Section 01530 - Protection and Restoration of Existing Facilities.
- E. Provisions concerning responsibilities for the adequacy of data furnished to prospective Bidders on subsurface conditions, underground utilities and other physical conditions, and possible changes in the Contract Documents due to differing conditions appear in Paragraphs 4.2, 4.3, and 4.4 of the General Conditions.
- F. Before submitting a Bid, each Bidder will, at its own expense, make or obtain any additional examinations, investigations, explorations, tests, and studies and obtain any additional information and data which pertain to the physical conditions (surface, subsurface, and underground utilities) at, or contiguous to, the site or otherwise which may affect cost, progress, or performance of the WORK and which the Bidder deems necessary to determine its Bid for performing the WORK in accordance with the time, price, and other terms and conditions of the Contract Documents.
- G. On request in advance, the OWNER will provide each Bidder access to the site to conduct such explorations and tests as each Bidder deems necessary for submission of a

SECTION 00100 - INSTRUCTIONS TO BIDDERS

Bid. Bidder shall fill all holes and shall clean up and restore the site to its former condition upon completion of such explorations.

- H. The lands upon which the WORK is to be performed, rights-of-way and easements for access thereto and the lands designated for use by the CONTRACTOR in performing the WORK are identified in the Contract Documents. All additional lands and access thereto required for temporary construction facilities or storage of materials and equipment are to be provided by the CONTRACTOR. Easements for permanent structures or permanent changes in existing structures are to be obtained and paid for by the OWNER unless otherwise provided in the Contract Documents.
- I. The submission of a Bid will constitute an incontrovertible representation by the Bidder that the Bidder has complied with every requirement of Article 6, "Bidder's Examination of Contract Documents and Site" herein, that without exception the Bid is premised upon performing the WORK required by the Contract Documents and such means, methods, techniques, sequences, or procedures of construction as may be indicated in or required by the Contract Documents, and that the Contract Documents are sufficient in scope and detail to indicate and convey understanding of all terms and conditions for performance of the WORK.

8.0 BID FORM.

- A. The Bid shall be made on the Bid Schedule(s) bound herein, or on legible and complete copies thereof, and shall contain the following: Sections 00300 - Bid, 00310 – Bid Schedule, and the required Bid Security. In the event there is more than one Bid Schedule, the Bidder may bid on any individual schedule or on any combination of schedules. The envelope enclosing the sealed Bids shall be plainly marked in the upper left-hand corner with the name and address of the Bidder and shall bear the words "BID FOR," followed by the title of the Contract Documents for the WORK, the name of the OWNER, the address where Bids are to be delivered or mailed to, and the date and hour of opening of Bids. The Bid Security shall be enclosed in the same envelope with the Bid.
- B. All blanks on the Bid Form and Bid Schedule(s) must be completed in ink or typed.
- C. Bids by corporations shall be executed in the corporate name by the president, a vice-president (or another corporate officer). The corporate address and state of incorporation must appear below the signature.
- D. Bids by partnerships must be executed in the partnership name and be signed by a managing partner, and the official address of the partnership must appear below the signature.
- E. The Bidder's Bid shall be signed with ink. All names must be printed or typed below the signature.
- F. The Bid shall contain an acknowledgment of receipt of all Addenda, the numbers of which must be filled in on the Bid Form. Failure to acknowledge Addenda shall render Bid non-responsive and shall cause its rejection.
- G. The address to which communications regarding the Bid are to be directed must be shown.

SECTION 00100 - INSTRUCTIONS TO BIDDERS

- H. All Bidders shall provide evidence of authority to conduct business in Alaska to the extent required by law.
- I. On Projects including Federal funding, any contractor otherwise qualified to perform the WORK is not required to be licensed nor to submit application for license in advance of submitting a Bid or having such Bid considered; provided, however, that such exemption does not constitute a waiver of the OWNER's right under existing license laws to require a contractor, determined to be a successful Bidder, to be licensed to do business as a contractor in the State of Alaska in connection with the award of a contract to the successful Bidder.
- J. A Bid for the WORK will not be accepted from a contractor who does not hold a valid Alaska Business License and a valid Contractor's License in Alaska (applicable to the type of work bid upon) at the time of opening Bids.

9.0 BID ALTERNATES. The project contains the following alternates:

- A. Not Used.

10.0 QUANTITIES OF WORK. The quantities of WORK, or material, stated in unit price items of the Bid are supplied only to give an indication of the general scope of the WORK; the OWNER does not expressly or by implication agree that the actual amount of WORK, or material, will correspond therewith, and reserves the right after award to increase or decrease the amount of any unit price item of the WORK by an amount up to and including 25 percent of any Bid item, without a change in the unit price, and shall include the right to delete any Bid item in its entirety, or to add additional Bid items up to and including an aggregate total amount not to exceed 25 percent of the Contract Price (see General Conditions, Article 10 Changes In the Work).

11.0 SUBSTITUTE OR "OR-EQUAL" ITEMS. The procedure for the submittal of substitute or "or-equal" products is specified in Section 01300 - Contractor Submittals.

12.0 SUBMISSION OF BIDS. The Bid shall be delivered by the time and to the place stipulated in the Notice Inviting Bids. It is the Bidder's sole responsibility to see that its Bid is received in proper time. Oral, telegraphic, telephonic or faxed Bids will not be considered.

13.0 BID SECURITY, BONDS, AND INSURANCE. Each Bid shall be accompanied by a certified, or cashier's check, or approved Bid Bond in an amount of at least 5 percent of the total Bid price. The "total Bid price" is the amount of the base bid, plus the amount of alternate bids, if any, which total to the maximum amount for which the contract could be awarded. Said check or Bond shall be made payable to the OWNER and shall be given as a guarantee that the Bidder, if offered the WORK, will enter into an Agreement with the OWNER, and will furnish the necessary insurance certificates, Payment Bond, and Performance Bond; each of said Bonds, if required, and insurance amounts shall be as stated in the Supplementary General Conditions. In case of refusal or failure to enter into said Agreement, the check or Bid Bond, as the case may be, shall be forfeited to the OWNER. If the Bidder elects to furnish a Bid Bond as its Bid security, the Bidder shall use the Bid Bond form bound herein, or one conforming substantially to it in form. Bid Bonds must be accompanied by a legible power of attorney.

14.0 RETURN OF BID SECURITY. Within 14 Days after award of the contract, the OWNER will return the Bid securities accompanying such of the Bids as are not considered in making the

SECTION 00100 - INSTRUCTIONS TO BIDDERS

award. All other Bid securities will be held until the Agreement has been executed. They will then be returned to the respective Bidders whose Bids they accompanied.

15.0 DISCREPANCIES IN BIDS. In the event there is more than one pay item in a Bid Schedule, the Bidder shall furnish a price for all pay items in the schedule, and failure to do so may render the Bid non-responsive and cause its rejection. In the event there are unit price pay items in a Bid Schedule and the “amount” indicated for a unit price pay item does not equal the product of the unit price and quantity, the unit price shall govern and the amount will be corrected accordingly, and the Bidder shall be bound by said correction. In the event there is more than one pay item in the Bid Schedule and the total indicated for the schedule does not agree with the sum of the prices bid on the individual items, the prices bid on the individual items shall govern and the total for the schedule will be corrected accordingly, and the Bidder shall be bound by the correction.

16.0 BID MODIFICATIONS AND UNAUTHORIZED ALTERNATIVE BIDS.

A. Any Bidder may modify a Bid by mail, email (clerk@wrangell.com), or fax (**Fax: 907-874-3952**) provided that such modification is received by the OWNER prior to the time set for opening of Bids. Bid modifications shall be made using the project Modified Bid Schedule form and shall be used with bid modifications made as a line by line pay item adjustment per the schedule. Bidders are strongly advised to telephone the City & Borough of Wrangell (**Telephone: 907-874-2381**) to confirm the successful and timely transmission of all email and fax Bid modifications.

An email or fax Bid Modification shall not reveal the Bid price but shall provide the addition or subtraction or other modification so that the final prices will not be known by the OWNER until the sealed Bid is opened. Modifications shall include both the modification of the unit bid price and the total modification of each item modified. The OWNER shall not be responsible for its failure to receive fax modifications whether such failure is caused by transmission line problems, fax device problems, operator error or otherwise.

B. Unauthorized conditions, limitations, or provisions attached to the Bid will render it informal and cause its rejection as being non-responsive. The completed bid forms shall be without interlineation, alterations, or erasures in the printed text. All changes shall be initialed by the person signing the Bid. Alternative bids will not be considered unless called for.

17.0 WITHDRAWAL OF BID. The Bid may be withdrawn by the Bidder by means of a written request, signed by the Bidder or its properly authorized representative. Such written request must be delivered to the place stipulated in the Notice Inviting Bids for receipt of Bids prior to the scheduled closing time for receipt of Bids.

18.0 AWARD OF CONTRACT.

A. Award of a contract, if it is awarded, will be on the basis of materials and equipment described in the Drawings or specified in the Technical Specifications and will be made to the lowest responsive, responsible Bidder whose Bid complies with all the requirements prescribed. Unless otherwise specified, any such award will be made within the period stated in the Notice Inviting Bids that the Bids are to remain open. Unless otherwise indicated, a single award will be made for all the pay items in an individual Bid Schedule.

SECTION 00100 - INSTRUCTIONS TO BIDDERS

- B. If the OWNER has elected to advertise this Project with a base bid and additive or deductive alternates, the OWNER may elect to award the contract for the base bid, or the base bid plus one or more alternates selected by the OWNER. In either case, award shall be made to the responsive, responsible Bidder offering the lowest total bid for the WORK to be awarded.
- C. Low Bidder will be determined based on the lowest total of the base bid plus combinations of additive alternatives as deemed in the best interest of the OWNER.
- D. A Local Bidder Preference shall apply to all City and Borough of Wrangell procurements, except when restricted by state or federal regulations. To be considered a qualifying bidder, bidders shall meet the requirements of the Local Bidder Preference ordinance, according to WMC 5.10.040 (D). The Owner may request documentation to support entries made on this form.

The Wrangell Municipal Code (WMC) Article 5.10.040, Section D. LOCAL BIDDER PREFERENCE AWARD reads:

1. Unless contrary to federal or state law or regulation, or as otherwise provided in section (D)(2) of this section, a contract for, or purchase of, supplies, materials, equipment, contractual services, or public improvements shall be awarded to a local bidder where the bid by such local bidder is in all material respects comparable to the lowest responsible nonlocal bid, and if the amount bid by such local bidder does not exceed the lowest responsible nonlocal bid by more than:
 - a. Five percent of the amount bid by the lowest responsible nonlocal bidder if that nonlocal bidder's bid is \$1,000,000 or less;
 - b. Three percent of the amount bid by the lowest responsible nonlocal bidder if that nonlocal bidder's bid is \$1,000,001 or more.
2. This preference shall not be interpreted to mean that the borough is precluded from making the purchase from whatever source is most advantageous to the borough after considering all factors in the public interest even when the price quoted by the local bidder satisfies subsection (D)(1)(a) or (b) of this section.
3. "Local bidder" for purposes of the section shall mean a bidder who:
 - a. Holds a current Alaska business license;
 - b. Submits a bid for goods or services under the name appearing on the person's current Alaska business license;
 - c. Has maintained a place of business within the boundaries of the borough for a period of six months immediately preceding the date of the bid;

SECTION 00100 - INSTRUCTIONS TO BIDDERS

- d. Is not delinquent in the payment of any utilities, taxes, charges or assessments owing to the borough on account of that business;
- e. Is incorporated or qualified to do business under the laws of Alaska with its principal place of business in the borough, is a proprietorship and the proprietor is a resident of the borough, or is a partnership and all partners are residents of the City and Borough of Wrangell;
- f. If a joint venture, all joint venture partners must qualify under subsection (D)(3)(a) through (e) of this section;
- g. The manager may require such documentation or verification by the person claiming to be a local bidder as is deemed necessary to establish the requirements of this section.

19.0 EXECUTION OF AGREEMENT.

- A. All Bids must be approved by the Wrangell Borough Assembly. After the Assembly has approved the award, the OWNER will issue a Notice of Intent to Award to the approved Bidder following the Bid Opening. The Bidder to whom award is made shall execute a written Agreement with the OWNER on the Agreement form, Section 00500, and shall secure all insurance and furnish all certificates and bonds required by the Contract Documents within 10 Days from the date stated in the Notice of Intent to Award letter.
- B. Failure or refusal to enter into the Agreement as herein provided or to conform to any of the stipulated requirements in connection therewith shall be just cause for annulment of the award and forfeiture of the Bid security. If the lowest responsive, responsible Bidder refuses or fails to execute the Agreement, the OWNER may award the contract to the second lowest responsive, responsible Bidder. If the second lowest responsive, responsible Bidder refuses or fails to execute the Agreement, the OWNER may award the contract to the third lowest responsive, responsible Bidder. On the failure or refusal of such second or third lowest Bidder to execute the Agreement, each such Bidder's Bid securities shall be likewise forfeited to the OWNER.

20.0 LIQUIDATED DAMAGES. Provisions for liquidated damages are set forth in the Agreement.

21.0 PERMITS. The CONTRACTOR is responsible for all WORK associated with meeting any local, state, and federal permit requirements as identified in Section 00852 Permits.

END OF SECTION



CITY AND BOROUGH OF WRANGELL

LOCAL BIDDER PREFERENCE AFFIDAVIT

In response to the Invitation to Bid for:

Project Name: _____

I certify under penalty of perjury that (Bidder Name)

_____ qualifies for the City and Borough of Wrangell's Local Bidder's Preference under the following conditions:

- A. If a bidder qualifies under WMC 5.10.040 (D) as a Local Bidder and is a qualifying entity, a five percent (5%) bid preference shall be applied to the bid price for the purpose of award. In this subsection, a "qualifying entity" means a local bidder who:
1. Holds a current Alaska business license;
 2. Submits a bid for goods or services under the name appearing on the person's current Alaska business license;
 3. Has maintained a place of business within the boundaries of the borough for a period of six months immediately preceding the date of the bid;
 4. Is not delinquent in the payment of any utilities, taxes, charges or assessments owing to the borough on account of that business;
 5. Is incorporated or qualified to do business under the laws of Alaska with its principal place of business in the borough, is a proprietorship and the proprietor is a resident of the borough, or is a partnership and all partners are residents of the City and Borough of Wrangell;
 6. If a joint venture, all joint venture partners must qualify under subsection (D)(3)(a) through (e) of this section.

The Owner may request documentation to support entries made on this form.

Authorized Signature

Printed Name

Date

SECTION 00300 - BID

BID TO: CITY AND BOROUGH OF WRANGELL

For Project Name: REID STREET SIDEWALK REPLACEMENT

By Company Name: _____

To the Contracting Officer, City and Borough of Wrangell:

1. In compliance with your Invitation to Bid for the above-referenced project, the undersigned proposes to furnish and deliver all the materials and to perform all the work and labor required in the construction of the Project, located in Wrangell, Alaska, according to all of the terms in the plans and specifications and for the amount and prices named herein as indicated on the Bid Schedule which is made a part of this Bid.
2. If this Bid is accepted, the undersigned does hereby agree to enter into an Agreement with the OWNER on the form included in the Contract Documents (as defined in Article 7 of Section 00500 - Agreement) to perform the WORK as specified or indicated in said Contract Documents.
3. This Bid will remain open for the period stated in the "Notice Inviting Bids" unless otherwise required by law. The undersigned will enter into an Agreement within the time and in the manner required in the "Notice Inviting Bids" and the "Instructions to Bidders." The undersigned agrees to commence the work within 10 calendar days, unless otherwise stipulated in the contract, and to complete the work within by the Substantial Completion Date provided in the contract, after the effective date of the Notice to Proceed, unless extended in writing by the Owner.
4. The undersigned will furnish insurance certificates, Payment Bond, Performance Bond, and any other documents as required by the Contract Documents as surety for the full, complete and faithful performance of this contract.
5. Bidder has familiarized itself with the nature and extent of the Contract Documents, WORK, site, locality where the WORK is to be performed, the legal requirements (federal, state and local laws, ordinances, rules, and regulations), and the conditions affecting cost, progress or performance of the WORK and has made such independent investigations as Bidder deems necessary.
6. The Undersigned declares that they have carefully examined the contract requirements and that they have made a personal examination of the site of the work; that they understand that the quantities, where such are specified in the Bid Schedule or on the plans for this project, are approximate only and subject to increase or decrease, and that they are willing to perform increased or decreased quantities of work at unit prices bid under the conditions set forth in the Contract Documents.
7. This Bid is genuine and not made in the interest of or on behalf of any undisclosed person, firm or corporation and is not submitted in conformity with any agreement or rules of any group, association, organization or corporation; Bidder has not directly or indirectly induced or solicited any other Bidder to submit a false or sham Bid; Bidder has not solicited or induced any person, firm or corporation to refrain from bidding; and Bidder has not sought by collusion to obtain for itself any advantage over any other Bidder or over OWNER.
8. To all the foregoing, and including all Bid Schedule and information required of Bidder contained in this Bid Form, said Bidder further agrees to complete the WORK required under the Contract

SECTION 00300 - BID

Documents within the Contract Time stipulated in said Contract Documents, and to accept in full payment therefor the Contract Price based on the total bid price(s) named in the Bid Schedule.

9. The undersigned has examined copies of all the Contract Documents and acknowledges receipt of the following addenda to the drawings and/or specifications

Addenda No.	Date Issued	Addenda No.	Date Issued

Give number and date of each Addendum above. Failure to acknowledge receipt of all Addenda will cause the Bid to be non-responsive and shall cause its rejection.

10. The undersigned has read the forgoing and hereby agrees to the conditions stated therein by affixing their signature below.

Dated: _____	Bidder: _____ (Company Name)
Contractor's License No.: _____	By: _____ (Signature in Ink)
Telephone No.: _____	Printed Name: _____
Email: _____	Title: _____
	Address: _____ (Street or P.O. Box)

	(City, State, Zip)

11. **DOCUMENTS REQUIRED FOR BID. TO BE CONSIDERED, ALL BIDDERS MUST COMPLETE AND INCLUDE THE FOLLOWING AT THE TIME OF THE BID OPENING:**

- Bid form, Section 00300
- Bid Schedule, Section 00310
- Bid Security, Section 00320

12. **REQUIRED AFTER NOTICE OF APPARENT LOW BIDDER.** Unless otherwise notified by the OWNER, the apparent low Bidder is required to complete and submit the following document within five (5) working days following notice of apparent low bidder:

- Subcontractor Report, Section 00360

13. **REQUIRED FOR AWARD.** To be awarded the contract, the successful Bidder must complete and submit, within ten (10) days after the date of the "Notice of Intent to Award" letter, the following executed documents:

- Alaska Business License
- Contractor's License
- Agreement Form, Section 00500

SECTION 00300 - BID

- Performance Bond, Section 00610
- Payment Bond, Section 00620
- Certificates of Contractor Insurance Section 00700 and Section 00800

14. The successful Bidder will be required to submit, within ten Days after the date stated in the “Notice to Proceed” the following executed documents:

- Certificates of Subcontractor Insurance Section 00700 and Section 00800
- One executed copy of each subcontract for WORK that exceeds one half of one percent of the intended contract award amount.

END OF SECTION

SECTION 00310 - BID SCHEDULE

Bidders Please Note: Before preparing this Bid Schedule, carefully read the Invitation for Bids, Instructions to Bidders, and the Technical Specifications.

The Bidder shall insert a unit price opposite each pay item in the Bid Schedule and multiply the unit price by the estimated quantities for this contract. No price is to be tendered for any item not appearing in the Bid Schedule.

In the event there is more than one pay item in the Bid Schedule and the total indicated for the schedule does not agree with the sum of the prices bid on the individual items, the prices bid on the individual items shall govern and the total for the schedule will be corrected accordingly, and the Bidder shall be bound by the correction.

A Local Bidder Preference of five percent (5%) X will, _____ will not be utilized on this project for the purpose of award.

HERITAGE HARBOR BOAT RAMP CONCRETE PAVING

Pay Item No.	Pay Item Description	Pay Unit	Approximate Quantity	Unit Price		Amount	
				Dollars	Cents	Dollars	Cents
01505.1	Mobilization	LS	All Req'd				
2204.1	Base Course	CY	25				
2220.1	Demolition	LS	All Req'd				
3301.1	Concrete Sidewalk, Curb and Gutter	CY	20				
5520.1	Guardrail and Railings	LF	130				

TOTAL REID STREET SIDEWALK REPLACEMENT IN FIGURES:

\$ _____

TOTAL REID STREET SIDEWALK REPLACEMENT AMOUNT IN WORDS:

BIDDER NAME: _____

BIDDER'S TELEPHONE: _____

END OF SECTION

SECTION 00320 - BID BOND

KNOW ALL PERSONS BY THESE PRESENTS, that _____

_____ as Principal, and _____

as Surety, are held and firmly bound unto the **CITY AND BOROUGH OF WRANGELL** hereinafter called "OWNER," in the sum of _____ dollars, (not less than five percent (5%) of the total amount of the Bid) for the payment of which sum, well and truly to be made, we bind ourselves, our heirs, executors, administrators, successors, and assigns, jointly and severally, firmly by these presents.

WHEREAS, said Principal has submitted a Bid to said OWNER to perform the WORK required under the Bid Schedule of the OWNER's Contract Documents entitled

REID STREET SIDEWALK REPLACEMENT

NOW THEREFORE, if said Principal is awarded a contract by said OWNER and, within the time and in the manner required in the "Notice Inviting Bids" and the "Instructions to Bidders" enters into a written Agreement on the form of Agreement bound with said Contract Documents, furnishes the required certificates of insurance, and furnishes the required Performance Bond and Payment Bond, then this obligation shall be null and void, otherwise it shall remain in full force and effect. In the event suit is brought upon this bond by said OWNER and OWNER prevails, said Surety shall pay all costs incurred by said OWNER in such suit, including a reasonable attorney's fee to be fixed by the court.

SIGNED AND SEALED, this _____ day of _____, 20__

(SEAL) _____
(Principal)

(SEAL) _____
(Surety)

By: _____
(Signature)

By: _____
(Signature)

END OF SECTION

SECTION 00360 - SUBCONTRACTOR REPORT

LIST OF SUBCONTRACTORS

The apparent low Bidder must submit a list of Subcontractors that the Bidder proposes to use in the performance of this contract by close of business on the fifth calendar day following the posting of the bid tabulations. If the fifth calendar day falls on a weekend or holiday, the report is due by close of business on the next business day following the weekend or holiday. The list must include each Subcontractor's name, address, location, evidence of valid Alaska Business License, and valid Alaska Contractor's Registration under AS 08.18. *If no Subcontractors are to be utilized in the performance of the WORK, write in ink or type "NONE" on line (1) below.*

<u>SUBCONTRACTOR</u>	¹ AK Contractor <u>License No.</u>	¹ <u>Contact Name</u>	<u>Type of</u>	<u>Contract</u>	<input type="checkbox"/>
<u>ADDRESS</u>	² AK Business <u>License No.</u>	² <u>Phone No.</u>	<u>Work</u>	<u>Amount</u>	<input type="checkbox"/> [✓] if <u>DBE</u>
1. _____ _____ _____	1 _____ 2 _____	_____ _____	_____ _____	\$ _____	<input type="checkbox"/>
2. _____ _____ _____	1 _____ 2 _____	_____ _____	_____ _____	\$ _____	<input type="checkbox"/>
3. _____ _____ _____	1 _____ 2 _____	_____ _____	_____ _____	\$ _____	<input type="checkbox"/>
4. _____ _____ _____	1 _____ 2 _____	_____ _____	_____ _____	\$ _____	<input type="checkbox"/>

I certify that the above listed Alaska Business License(s) and CONTRACTOR Registration(s), if applicable, were valid at the time Bids were opened for this Project.

CONTRACTOR, Authorized Signature

CONTRACTOR, Printed Name

SECTION 00360 - SUBCONTRACTOR REPORT

- A. A Bidder may replace a listed Subcontractor if the Subcontractor:
1. fails to comply with AS 08.18;
 2. files for bankruptcy or becomes insolvent;
 3. fails to execute a contract with the Bidder involving performance of the WORK for which the Subcontractor was listed and the Bidder acted in good faith;
 4. fails to obtain bonding;
 5. fails to obtain insurance acceptable to the OWNER;
 6. fails to perform the contract with the Bidder involving work for which the Subcontractor was listed;
 7. must be substituted in order for the CONTRACTOR to satisfy required state and federal affirmative action requirements;
 8. refuses to agree or abide with the Bidder's labor agreement; or
 9. is determined by the OWNER not to be a responsible Bidder.
- B. If a Bidder fails to list a Subcontractor or lists more than one Subcontractor for the same portion of WORK, the Bidder shall be considered to have agreed to perform that portion of WORK without the use of a Subcontractor and to have represented the Bidder to be qualified to perform that WORK.
- C. A Bidder who attempts to circumvent the requirements of this section by listing as a Subcontractor another contractor who, in turn, sublets the majority of the WORK required under the contract violates this section.
- D. If a contract is awarded to a Bidder who violates this section, the OWNER may:
1. cancel the contract; or
 2. after notice and a hearing, assess a penalty on the Bidder in an amount that does not exceed 10 percent of the value of the subcontract at issue.
- E. For contract award, the apparent low Bidder must submit one copy of each subcontract, to the OWNER, for WORK with a value of greater than one half of one percent of the intended award amount.
- F. An apparent low Bidder who fails to submit a completed Subcontractor Report within the time specified in this section will be found to be not a responsible Bidder and may be required to forfeit the Bid security. The OWNER will then consider the next lowest Bidder for award of the contract.

END OF SECTION

SECTION 00500 - AGREEMENT

THIS AGREEMENT is between THE CITY & BOROUGH OF WRANGELL (hereinafter called OWNER) and _____ (hereinafter called CONTRACTOR) OWNER and CONTRACTOR, in consideration of the mutual covenants hereinafter set forth, agree as follows:

ARTICLE 1. WORK.

- A. CONTRACTOR shall complete the WORK as specified or as indicated under the Bid Schedule of the OWNER's Contract Documents entitled **REID STREET SIDEWALK REPLACEMENT**. The WORK is generally described as follows: The Work consists of all activities necessary to construct the Reid Street Sidewalk Replacement project, including asphalt cutting, concrete and guardrail demolition and disposal, excavation, base course, and concrete placement.

ARTICLE 2. CONTRACT COMPLETION TIME.

The OWNER will open the work site to the CONTRACTOR immediately upon issuing a Notice to Proceed. Substantial Completion must be reached by August 19, 2022. Final Completion, including handrail installation must be reached no later than September 30, 2022.

ARTICLE 3. DATE OF AGREEMENT

The date of this Agreement will be the later of the date of the Borough Manager signature on page three of this section and the signature of the CONTRACTOR authorized representative.

ARTICLE 4. LIQUIDATED DAMAGES.

OWNER and the CONTRACTOR recognize that time is of the essence of this Agreement and that the OWNER will suffer financial loss if the WORK is not completed within the time specified in Article 2 herein, plus any extensions thereof allowed in accordance with Article 12 of the General Conditions. They also recognize the delays, expense, and difficulties involved in proving in a legal proceeding the actual damages suffered by the OWNER if the WORK is not completed on time. Accordingly, instead of requiring any such proof, the OWNER and the CONTRACTOR agree that as liquidated damages for delay (but not as a penalty) the CONTRACTOR shall pay the OWNER \$ 1,500 for each Calendar Day that expires after the substantial completion time specified in Article 2 above. The amount of liquidated damages specified above is agreed to be a reasonable estimate based on all facts known as of the date of this Agreement.

ARTICLE 5. CONTRACT PRICE.

OWNER shall pay CONTRACTOR for completion of the WORK in accordance with the Contract Documents in the amount set forth in the Bid Schedule. The CONTRACTOR agrees to accept as full and complete payment for all WORK to be done in this contract for: \$ _____ (IN WORDS) those Unit Price amounts as set forth in the Bid Schedule in the Contract Documents for this Project.

The total amount of this contract shall be \$ _____ except as adjusted in accordance with the provisions of the Contract Documents.

ARTICLE 6. PAYMENT PROCEDURES.

CONTRACTOR shall submit Applications for Payment in accordance with Article 14 of the General

SECTION 00500 - AGREEMENT

Conditions. Applications for Payment will be processed by the ENGINEER as provided in the General Conditions.

Progress payments will be paid in full in accordance with Article 14 of the General Conditions until ninety (90) percent of the Contract Price has been paid. The remaining ten (10) percent of the Contract Price may be retained, in accordance with applicable Alaska State Statutes, until final inspection, completion, and acceptance of the Project by the OWNER.

ARTICLE 7. CONTRACT DOCUMENTS.

The Contract Documents which comprise the entire Agreement between OWNER and CONTRACTOR concerning the WORK consist of this Agreement (pages 00500-1 to 00500-6, inclusive) and the following sections of the Contract Documents:

- Table of Contents
- Notice Inviting Bids
- Instructions to Bidders
- Bid
- Bid Schedule
- Bid Bond
- Subcontractor Report
- Performance Bond
- Payment Bond
- Insurance Certificate(s)
- General Conditions
- Supplementary General Conditions
- Alaska Labor Standards, Reporting, and Prevailing Wage Determination
- Technical Specifications as listed in the Table of Contents
- Drawings consisting of ___ sheets
- Addenda numbers ___ to ___, inclusive.
- Change Orders which may be delivered or issued after the Date of the Agreement and which are not attached hereto.

There are no Contract Documents other than those listed in this Article 7. The Contract Documents may only be amended by Change Order as provided in Paragraph 3.3 of the General Conditions.

ARTICLE 8. MISCELLANEOUS.

Terms used in this Agreement, which are defined in Article 1 of the General Conditions, will have the meanings indicated in the General Conditions.

No assignment by a party hereto of any rights under or interests in the Contract Documents will be binding on another party hereto without the written consent of the party sought to be bound; and specifically but without limitation monies that may become due and monies that are due may not be assigned without such written consent (except to the extent that the effect of this restriction may be limited by law), and unless specifically stated to the contrary in any written consent to an assignment, no assignment will release or discharge the assignor from any duty or responsibility under the Contract Documents. CONTRACTOR understands and agrees that the Borough will not accept any assignment of this Contract to an LLC unless all the members of the LLC sign as guarantors of performance of this

SECTION 00500 - AGREEMENT

Contract.

OWNER and CONTRACTOR each binds itself, its partners, successors, assigns and legal representatives to the other party hereto, its partners, successors, assigns and legal representatives in respect of all covenants, agreements and obligations contained in the Contract Documents. This Agreement shall be governed by the laws of the State of Alaska. The Superior Court for the State of Alaska, First Judicial District at Wrangell, Alaska, shall be the exclusive jurisdiction and venue for any action of any kind an any nature arising out of or relating to this Agreement and all Contract documents or for any action of any kind and any nature arising out of or related to the performance of non-performance of the CONTRACTOR, and CONTRACTOR’S employees, subcontractors, consultants and representatives.

The CONTRACTOR acknowledges that the CONTRACTOR has read and understands the terms of this Agreement and the terms and conditions of all the Contract documents listed in this Agreement and has had the opportunity to review the Agreement with counsel of his/her choice, and is executing this Agreement of his/her own free will. CONTRACTOR acknowledges and agrees that CONTRACTOR is not relying on any representations by any Borough employee, the Mayor, an assembly member, the borough attorney, the borough manager or any consultant of the Borough in deciding to enter this Agreement and perform this project.

IN WITNESS WHEREOF, OWNER and CONTRACTOR have caused this Agreement to be executed on the date listed below by OWNER.

OWNER:

CONTRACTOR:

City & Borough of Wrangell

(Company Name)

(Signature)

(Signature)

By: Jeff Good, Borough Manager
(Printed Name)

By: _____
(Printed Name, Authority or Title)

Date: _____

Date: _____

Address: P.O. Box 531

Address: _____

Wrangell, Alaska 99929

907-874-2381 907-874-3952
(Telephone) (Fax)

(Telephone) (Fax)

(E-mail address)

Owner Attest:

Contractor Attest:

By: Kim Lane, Borough Clerk

By: _____
Name/Title:

SECTION 00500 - AGREEMENT

**CERTIFICATE
(if Corporation)**

STATE OF)
) SS:
COUNTY OF)

I HEREBY CERTIFY that a meeting of the Board of Directors of the
_____ a corporation existing under the laws of
the State of _____, held on _____, 20____, the following resolution
was duly passed and adopted:

“RESOLVED, that _____, as _____ President
of the Corporation, be and is hereby authorized to **execute the Agreement** with OWNER and this
corporation and that the execution thereof, attested by the Secretary of the Corporation, and with
the Corporate Seal affixed, shall be the official act and deed of this Corporation.”

I further certify that said resolution is now in full force and effect.

IN WITNESS WHEREOF, I have hereunto set my hand and affixed the official seal of the
Corporation this _____ day of _____, 20_____.

Secretary

(SEAL)

SECTION 00500 - AGREEMENT

CERTIFICATE
(if Partnership)

STATE OF)
) SS:
COUNTY OF)

I HEREBY CERTIFY that a meeting of the Partners of the _____ a partnership existing under the laws of the State of _____, held on _____, 20____, the following resolution was duly passed and adopted:

"RESOLVED, that _____, as _____ of the Partnership, be and is hereby authorized to **execute the Agreement** with the OWNER and this partnership and that the execution thereof, attested by the _____ shall be the official act and deed of this Partnership."

I further certify that said resolution is now in full force and effect.

IN WITNESS WHEREOF, I have hereunto set my hand this _____, day of _____, 20_____.

Secretary

(SEAL)

SECTION 00500 - AGREEMENT

CERTIFICATE
(if Joint Venture)

STATE OF)
) SS:
COUNTY OF)

I HEREBY CERTIFY that a meeting of the Principals of the

_____ a joint venture existing under the laws of the

State of _____, held on _____, 20____, the following resolution was duly passed and adopted:

"RESOLVED, that _____, as _____ of the Joint Venture, be and is hereby authorized to **execute the Agreement** with the OWNER and this joint venture and that the execution thereof, attested by the _____ shall be the official act and deed of this Joint Venture."

I further certify that said resolution is now in full force and effect.

IN WITNESS WHEREOF, I have hereunto set my hand this _____, day of _____, 20____.

Secretary

(SEAL)

SECTION 00500 - AGREEMENT

CERTIFICATE
(If Limited Liability Company)

STATE OF)
) SS:
COUNTY OF)

I HEREBY CERTIFY that a meeting of the members of the

_____, a Limited Liability Company (LLC) existing under the laws of the State of _____, held on _____, 20____, the following resolution was duly passed and adopted:

"RESOLVED, that _____, acting as _____ of the Limited Liability Company, is hereby authorized by all Members to **execute the Agreement** with the OWNER and this Limited Liability Company and that the execution thereof, attested by the _____ shall be the official act and deed of this Limited liability Company."

I further certify that said resolution is now in full force and effect.

IN WITNESS WHEREOF, I have hereunto set my hand this _____, day of _____, 20_____.

Secretary

(SEAL)

By: _____
(Signature of authorized Member)

(Title of person signing)

END OF SECTION

SECTION 00610 - PERFORMANCE BOND

KNOW ALL PERSONS BY THESE PRESENTS: That we _____
(Name of Contractor)

_____ a _____
(Corporation, Partnership, Individual)

hereinafter called "Principal" and _____
(Surety)

of _____, State of _____ hereinafter called the "Surety," are held and
firmly bound to the CITY & BOROUGH of WRANGELL, ALASKA hereinafter called "OWNER,"
(Owner) (City and State)

for the penal sum of _____

_____ dollars (\$ _____) in lawful money of the
United States, for the payment of which sum well and truly to be made, we bind ourselves, our heirs,
executors, administrators and successors, jointly and severally, firmly by these presents.

THE CONDITION OF THIS OBLIGATION is such that whereas, the CONTRACTOR has
entered into a certain contract with the OWNER, the effective date of which is
_____, a copy of which is hereto attached and made a part hereof for the
construction of:

REID STREET SIDEWALK REPLACEMENT

NOW, THEREFORE, if the Principal shall truly and faithfully perform its duties, all the
undertakings, covenants, terms, conditions, and agreements of said contract during the original term
thereof, and any extensions thereof, which may be granted by the OWNER, with or without notice to the
Surety, and if it shall satisfy all claims and demands incurred under such contract, and shall fully
indemnify and save harmless the OWNER from all costs and damages which it may suffer by reason of
failure to do so, and shall reimburse and repay the OWNER all outlay and expense which the OWNER
may incur in making good any default, then this obligation shall be void; otherwise to remain in full force
and effect.

PROVIDED, FURTHER, that the said Surety, for value received hereby stipulates and agrees that
no change, extension of time, alteration or addition to the terms of the contract or to the WORK to be
performed thereunder or the specifications accompanying the same shall in any wise affect its obligation
on this bond, and it does hereby waive notice of any such change, extension of time, alteration or addition
to the terms of the contract or to the WORK or to the Specifications.

PROVIDED, FURTHER, that no final settlement between the OWNER and the Principal shall
abridge the right of any beneficiary hereunder, whose claim may be unsatisfied.

IN WITNESS WHEREOF, this instrument is issued in two (2) identical counterparts, each one of
which shall be deemed an original.

SECTION 00610 - PERFORMANCE BOND

CONTRACTOR:

By: _____
(Signature)

(Printed Name)

(Company Name)

(Street or P.O. Box)

(City, State, Zip Code)

SURETY:

By: _____
(Signature of Attorney-in-Fact)

Date Issued: _____

(Printed Name)

(Company Name)

(Street or P.O. Box)

(City, State, Zip Code)

(Affix SURETY'S SEAL)

NOTE: If CONTRACTOR is Partnership, all Partners must execute bond.

END OF SECTION

SECTION 00620 - PAYMENT BOND

KNOW ALL PERSONS BY THESE PRESENTS: That we _____
(Name of Contractor)

_____ a _____
(Corporation, Partnership, Individual)

hereinafter called "Principal" and _____
(Surety)

of _____, State of _____ hereinafter called the "Surety," are held and
firmly bound to the CITY & BOROUGH of WRANGELL, ALASKA hereinafter called "OWNER,"
(Owner) (City and State)

for the penal sum of _____

_____ dollars (\$ _____) in lawful money of the
United States, for the payment of which sum well and truly to be made, we bind ourselves, our heirs,
executors, administrators and successors, jointly and severally, firmly by these presents.

THE CONDITION OF THIS OBLIGATION is such that whereas, the CONTRACTOR has
entered into a certain contract with the OWNER, the effective date of which is
_____, a copy of which is hereto attached and made a part hereof for the
construction of:

REID STREET SIDEWALK REPLACEMENT

NOW, THEREFORE, if the Principal shall promptly make payment to all persons, firms,
Subcontractors, and corporations furnishing materials for, or performing labor in the prosecution of the
WORK provided for in such contract, and any authorized extension or modification thereof, including all
amounts due for materials, lubricants, oil, gasoline, coal and coke, repairs on machinery, equipment and
tools, consumed or used in connection with the construction of such WORK, and all insurance premiums
on said work, and for all labor performed in such WORK, whether by Subcontractor or otherwise, then
this obligation shall be void; otherwise to remain in full force and effect.

PROVIDED, FURTHER, that the said Surety, for value received hereby stipulates and agrees that
no change, extension of time, alteration or addition to the terms of the contract or to the work to be
performed thereunder or the specifications accompanying the same shall in any wise affect its obligation
on this bond, and it does hereby waive notice of any such change, extension of time, alteration or addition
to the terms of the contract or to the WORK or to the Specifications.

PROVIDED, FURTHER, that no final settlement between the OWNER and the Principal shall
abridge the right of any beneficiary hereunder, whose claim may be unsatisfied.

SECTION 00620 - PAYMENT BOND

IN WITNESS WHEREOF, this instrument is issued in two (2) identical counterparts, each one of which shall be deemed an original.

CONTRACTOR:

By: _____
(Signature)

(Printed Name)

(Company Name)

(Street or P.O. Box)

(City, State, Zip Code)

SURETY:

By: _____
(Signature of Attorney-in-Fact)

Date Issued: _____

(Printed Name)

(Company Name)

(Street or P.O. Box)

(City, State, Zip Code)

(Affix SURETY'S SEAL)

NOTE: If CONTRACTOR is Partnership, all Partners must execute bond.

END OF SECTION

SECTION 00700 - GENERAL CONDITIONS

TABLE OF CONTENTS

ARTICLE 1 DEFINITIONS 00700-5

ARTICLE 2 PRELIMINARY MATTERS

2.1 Delivery of Bonds/Insurance Certificates 00700-8
2.2 Copies of Documents 00700-8
2.3 Commencement of Contract Time; Notice to Proceed 00700-9
2.4 Starting the WORK 00700-9
2.5 Pre-construction Conference 00700-9

ARTICLE 3 CONTRACT DOCUMENTS: INTENT, AMENDING, REUSE

3.1 Intent 00700-9
3.2 Order of Precedence of Contract Documents 00700-10
3.3 Amending and Supplementing Contract Documents 00700-10
3.4 Reuse of Documents 00700-10

ARTICLE 4 AVAILABILITY OF LANDS; PHYSICAL CONDITIONS; REFERENCE POINTS

4.1 Availability of Lands 00700-11
4.2 Physical Conditions - Subsurface and Existing Structures 00700-11
4.3 Differing Site Conditions 00700-11
4.4 Physical Conditions - Underground Utilities 00700-12
4.5 Reference Points 00700-12

ARTICLE 5 BONDS AND INSURANCE

5.1 Performance, Payment and Other Bonds 00700-13
5.2 Insurance 00700-13

ARTICLE 6 CONTRACTOR’S RESPONSIBILITIES

6.1 Supervision and Superintendence 00700-14
6.2 Labor, Materials, and Equipment 00700-14
6.3 Adjusting Progress Schedule 00700-16
6.4 Substitutes or “Or Equal” Items 00700-16
6.5 Concerning Subcontractors, Suppliers and Others 00700-16
6.6 Permits 00700-16
6.7 Patent Fees and Royalties 00700-17
6.8 Laws and Regulations 00700-17

SECTION 00700 - GENERAL CONDITIONS

ARTICLE 6 CONTRACTOR’S RESPONSIBILITIES (Cont’d.)

6.9 Taxes 00700-17
6.10 Use of Premises..... 00700-18
6.11 Safety and Protection 00700-18
6.12 Shop Drawings and Samples..... 00700-19
6.13 Continuing the WORK..... 00700-19
6.14 Indemnification 00700-19
6.15 Contractor’s Daily Reports 00700-20
6.16 Assignment of Contract 00700-20
6.17 Contractor’s Responsibility for Utility Property and Services 00700-20
6.18 Operating Water System Valves 00700-21
6.19 CONTRACTOR’S WORK Schedule Limitations 00700-21

ARTICLE 7 OTHER WORK

7.1 Related WORK at Site 00700-21
7.2 Coordination..... 00700-22

ARTICLE 8 OWNER’S RESPONSIBILITIES

8.1 Communications 00700-22
8.2 Payments 00700-22
8.3 Lands, Easements, and Surveys 00700-22
8.4 Change Orders..... 00700-22
8.5 Inspections and Tests 00700-22
8.6 Suspension of WORK..... 00700-22
8.7 Termination of Agreement..... 00700-22

ARTICLE 9 ENGINEER’S STATUS DURING CONSTRUCTION

9.1 OWNER’s Representative 00700-22
9.2 Visits to Site 00700-22
9.3 Project Representation 00700-23
9.4 Clarifications and Interpretations..... 00700-25
9.5 Authorized Variations in WORK..... 00700-25
9.6 Rejecting Defective WORK..... 00700-25
9.7 CONTRACTOR Submittals, Change Orders, and Payments 00700-25
9.8 Decisions on Disputes 00700-25
9.9 Limitation on Engineer’s Responsibilities 00700-26

ARTICLE 10 CHANGES IN THE WORK

10.1 General 00700-27
10.2 Allowable Quantity Variations 00700-27

ARTICLE 11 CHANGE OF CONTRACT PRICE

SECTION 00700 - GENERAL CONDITIONS

11.1 General..... 00700-28
11.2 Costs Relating to Weather..... 00700-28
11.3 Cost of WORK (Based on Time and Materials) 00700-29
11.4 CONTRACTOR’S Fee 00700-31
11.5 Excluded Costs..... 00700-32

ARTICLE 12 CHANGE OF CONTRACT TIME

12.1 General..... 00700-33
12.2 Extensions of Time for Delay Due to Weather..... 00700-33

ARTICLE 13 WARRANTY AND GUARANTEE; TESTS AND INSPECTIONS, CORRECTION, REMOVAL, OR ACCEPTANCE OF DEFECTIVE WORK

13.1 Warranty and Guarantee 00700-34
13.2 Access to WORK..... 00700-34
13.3 Tests and Inspections 00700-34
13.4 OWNER May Stop the WORK 00700-35
13.5 Correction or Removal of Defective WORK..... 00700-35
13.6 One Year Correction Period..... 00700-35
13.7 Acceptance of Defective WORK..... 00700-36

ARTICLE 14 PAYMENTS TO CONTRACTOR AND COMPLETION

14.1 Schedule of Values (Lump Sum Price Breakdown)..... 00700-36
14.2 Unit Price Bid Schedule..... 00700-36
14.3 Application for Progress Payment 00700-36
14.4 CONTRACTOR’S Warranty of Title 00700-37
14.5 Review of Applications for Progress Payment 00700-37
14.6 Partial Utilization 00700-38
14.7 Substantial Completion..... 00700-38
14.8 Final Application for Payment..... 00700-38
14.9 Final Payment and Acceptance 00700-38
14.10 Release of Retainage and Other Deductions 00700-39
14.11 CONTRACTOR’S Continuing Obligation 00700-39
14.12 Final Payment Terminates Liability of OWNER 00700-39

ARTICLE 15 SUSPENSION OF WORK AND TERMINATION

15.1 Suspension of WORK by OWNER 00700-40
15.2 Termination of Agreement by OWNER (CONTRACTOR Default)..... 00700-40
15.3 Termination of Agreement by OWNER (For Convenience) 00700-40
15.4 Termination of Agreement by CONTRACTOR..... 00700-41

ARTICLE 16 MISCELLANEOUS

16.1 Giving Notice..... 00700-41
16.2 Rights In and Use of Materials Found on the WORK 00700-41

SECTION 00700 - GENERAL CONDITIONS

16.3 Right to Audit..... 00700-42
16.4 Archaeological or Historical Discoveries 00700-42
16.5 Construction Over or Adjacent to Navigable Waters..... 00700-42
16.6 Gratuity and Conflict of Interest 00700-42
16.7 Suits of Law Concerning the WORK..... 00700-42
16.8 Certified Payrolls 00700-43
16.9 Prevailing Wage Rates 00700-43
16.10 Employment Reference..... 00700-44
16.11 Cost Reduction Incentive 00700-44

SECTION 00700 - GENERAL CONDITIONS

ARTICLE 1 DEFINITIONS

Wherever used in these General Conditions or in the other Contract Documents the following terms have the meanings indicated which are applicable to both the singular and plural thereof. Where an entire word is capitalized in the definitions and is found not capitalized in the Contract Documents it has the ordinary dictionary definition.

Addenda - Written or graphic instruments issued prior to the opening of Bids which make additions, deletions, or revisions to the Contract Documents.

Agreement - The written contract between the OWNER and the CONTRACTOR covering the WORK to be performed; other documents are attached to the Agreement and made a part thereof as listed out in the Agreement.

Application for Payment - The form furnished by the ENGINEER which is to be used by the CONTRACTOR to request progress or final payment and which is to be accompanied by such supporting documentation as is required by the Contract Documents.

Asbestos - Any material that contains more than one percent asbestos and is friable or is releasing asbestos fibers into the air above current action levels established by the United States Occupational Safety and Health Administration.

Bid - The offer or proposal of the Bidder submitted on the prescribed form setting forth the price or prices for the WORK.

Bonds - Bid, Performance, and Payment Bonds and other instruments which protect against loss due to inability or refusal of the CONTRACTOR to perform its contract.

Project Manager - The authorized representative of the City and Borough of Wrangell, as OWNER, who is responsible for administration of the contract.

Change Order - A document recommended by the ENGINEER, which is signed by the CONTRACTOR and the OWNER and authorizes an addition, deletion, or revision in the WORK, or an adjustment in the Contract Price or the Contract Time, issued on or after the Effective Date of the Agreement.

Contract Documents - The Table of Contents, Notice Inviting Bids, Instructions to Bidders, Bid Forms (including the Bid, Bid Schedule(s), Information Required of Bidder, Bid Bond, and all required certificates and affidavits), Agreement, Performance Bond, Payment Bond, General Conditions, Supplementary General Conditions, Technical Specifications, Drawings, Permits, and all Addenda, and Change Orders executed pursuant to the provisions of the Contract Documents.

Contract Price - The total monies payable by the OWNER to the CONTRACTOR under the terms and conditions of the Contract Documents.

Contract Time - The number of successive calendar days stated in the Contract Documents for the completion of the WORK.

CONTRACTOR - The individual, partnership, corporation, joint-venture or other legal entity with whom the OWNER has executed the Agreement.

Day - A calendar day of 24 hours measured from midnight to the next midnight.

SECTION 00700 - GENERAL CONDITIONS

Defective WORK - WORK that is unsatisfactory, faulty, or deficient; or that does not conform to the Contract Documents; or that does not meet the requirements of any inspection, reference standard, test, or approval referred to in the Contract Documents; or WORK that has been damaged prior to the ENGINEER's recommendation of final payment.

Drawings - The Drawings, plans, maps, profiles, diagrams, and other graphic representations which indicate the character, location, nature, extent, and scope of the WORK and which have been prepared by the ENGINEER and are referred to in the Contract Documents. Shop Drawings are not within the meaning of this paragraph.

Effective Date of the Agreement - The date indicated in the Agreement on which it becomes effective, but if no such date is indicated it means the date on which the Agreement is signed and delivered by the last of the two parties to sign and deliver.

Engineer of Record - The individual, partnership, corporation, joint-venture or other legal entity named as such in the Contract Documents.

ENGINEER - The ENGINEER is the firm or person(s) selected by the OWNER to perform the duties of project inspection and management. Wrangell will inform the CONTRACTOR of the identity of the ENGINEER at or before the Notice to Proceed.

Field Order - A written order issued by the ENGINEER which may or may not involve a change in the WORK.

General Requirements - Division 1 of the Technical Specifications.

Hazardous Waste - The term Hazardous Waste shall have the meaning provided in Section 1004 of the Solid Waste Disposal Act (42 USC Section 9603) as amended from time to time.

Holidays - Legal holidays occur on:

1. New Year's Day - January 1
2. Martin Luther King's Birthday - Third Monday in January
3. President's Day - Third Monday in February
4. Seward's Day - Last Monday in March
5. Memorial Day - Last Monday in May
6. Independence Day - July 4
7. Labor Day - First Monday in September
8. Alaska Day - October 18
9. Veteran's Day - November 11
10. Thanksgiving Day - Fourth Thursday and the following Friday in November
11. Christmas Day - December 25

If any holiday listed above falls on a Saturday, Saturday and the preceding Friday are both legal holidays. If the holiday should fall on a Sunday, Sunday and the following Monday are both legal holidays.

Inspector - The authorized representative of the ENGINEER assigned to make detailed inspections for conformance to the Contract Documents. Any reference to the Resident Project Representative in this document shall mean the Inspector.

SECTION 00700 - GENERAL CONDITIONS

Laws and Regulations; Laws or Regulations - Any and all applicable laws, rules, regulations, ordinances, codes, and/or orders of any and all governmental bodies, agencies, authorities and courts having jurisdiction.

Mechanic's Lien - A form of security, an interest in real property, which is held to secure the payment of an obligation. When referred to in these Contract Documents, "Mechanic's Lien" or "lien" means "Stop Notice".

Milestone - A principal event specified in the Contract Documents relating to an intermediate completion date of a portion of the WORK, or a period of time within which the portion of the WORK should be performed prior to Substantial Completion of all the WORK.

Notice of Intent to Award - The written notice by the OWNER to the apparent successful bidder stating that upon compliance by the apparent successful bidder with the requirements listed therein, within the time specified, the OWNER will enter into an Agreement.

Notice of Award - The written notice by the OWNER to the apparent successful bidder stating that the apparent successful bidder has complied with all conditions for award of the contract.

Notice of Substantial Completion - A form signed by the ENGINEER and the CONTRACTOR recommending to the OWNER that the WORK is Substantially Complete and fixing the date of Substantial Completion. After acceptance of the WORK by the OWNER's governing body, the form is signed by the OWNER and filed with the County Recorder. This filing starts the 30 day lien filing period on the WORK.

Notice to Proceed - The written notice issued by the OWNER to the CONTRACTOR authorizing the CONTRACTOR to proceed with the WORK and establishing the date of commencement of the Contract Time.

OWNER - The City and Borough of Wrangell, acting through its legally designated officials, officers, or employees.

Partial Utilization - Use by the OWNER or a substantially completed part of the WORK for the purpose for which it is intended prior to Substantial Completion of all the WORK.

PCB's - Polychlorinated biphenyls.

PERMITTEE - CONTRACTOR.

Petroleum - Petroleum, including crude oil or any fraction thereof which is liquid at standard conditions of temperature and pressure (60 degrees Fahrenheit and 14.7 pounds per square inch absolute), such as oil, petroleum, fuel oil, oil sludge, oil refuse, gasoline, kerosene, and oil mixed with other non-Hazardous Wastes and crude oils.

Project - The total construction of which the WORK to be provided under the Contract Documents may be the whole, or a part as indicated elsewhere in the Contract Documents.

Radioactive Material - Source, special nuclear, or byproduct material as defined by the Atomic Energy Act of 1954 (42 USC Section 2011 et seq.) as amended from time to time.

SECTION 00700 - GENERAL CONDITIONS

Shop Drawings - All Drawings, diagrams, illustrations, schedules and other data which are specifically prepared by or for the CONTRACTOR and submitted by the CONTRACTOR, to the ENGINEER, to illustrate some portion of WORK.

Specifications - (Same definition as for Technical Specifications hereinafter).

Stop Notice - A legal remedy for Subcontractors and suppliers who contribute to public works, but who are not paid for their WORK, which secures payment from construction funds possessed by the OWNER. For public property, the Stop Notice remedy is designed to substitute for mechanic's lien rights.

Sub-Consultant - The individual, partnership, corporation, joint-venture or other legal entity having a direct contract with ENGINEER, or with any of its Consultants to furnish services with respect to the Project.

Subcontractor - An individual, partnership, corporation, joint-venture or other legal entity having a direct contract with the CONTRACTOR, or with any of its Subcontractors, for the performance of a part of the WORK at the site.

Substantial Completion - Refers to when the WORK has progressed to the point where, in the opinion of the ENGINEER as evidenced by Notice of Completion as applicable, it is sufficiently complete, in accordance with the Contract Documents, so that the WORK can be utilized for the purposes for which it is intended; or if no such notice is issued, when final payment is due in accordance with Paragraph 14.8. The terms "substantially complete" and "substantially completed" as applied to any WORK refer to substantial completion thereof.

Supplementary General Conditions (SGC) - The part of the Contract Documents which make additions, deletions, or revisions to these General Conditions.

Supplier - A manufacturer, fabricator, supplier, distributor, materialman, or vendor.

Technical Specifications - Divisions 1 through 16 of the Contract Documents consisting of the General Requirements and written technical descriptions of products and execution of the WORK.

Underground Utilities - All pipelines, conduits, ducts, cables, wires, manholes, vaults, tanks, tunnels, or other such facilities or attachments, and any encasements containing such facilities which have been installed underground to furnish any of the following services or materials: water, sewage and drainage removal, electricity, gases, steam, liquid petroleum products, telephone or other communications, cable television, traffic, or other control systems.

WORK - The entire completed construction or the various separately identifiable parts thereof required to be furnished under the Contract Documents. WORK is the result of performing or furnishing labor and furnishing and incorporating materials and equipment into the construction, and performing or furnishing services and furnishing documents, all as required by the Contract Documents.

ARTICLE 2 PRELIMINARY MATTERS

2.1 DELIVERY OF BONDS/INSURANCE CERTIFICATES. When the CONTRACTOR delivers the signed Agreements to the OWNER, the CONTRACTOR shall also deliver to the OWNER such Bonds and Insurance Policies and Certificates as the CONTRACTOR may be required to furnish in accordance with the Contract Documents.

SECTION 00700 - GENERAL CONDITIONS

- 2.2 **COPIES OF DOCUMENTS.** The OWNER shall furnish to the CONTRACTOR the required number of copies of the Contract Documents specified in the Supplementary General Conditions.
- 2.3 **COMMENCEMENT OF CONTRACT TIME; NOTICE TO PROCEED.** The Contract Time will start to run on the commencement date stated in the Notice to Proceed.
- 2.4 **STARTING THE WORK**
- A. The CONTRACTOR shall begin to perform the WORK within 10 days after the commencement date stated in the Notice to Proceed, but no WORK shall be done at the site prior to the commencement date, including mobilization.
 - B. Before undertaking each part of the WORK, the CONTRACTOR shall carefully study and compare the Contract Documents and check and verify pertinent figures shown thereon and all applicable field measurements. The CONTRACTOR shall promptly report in writing to the ENGINEER any conflict, error, or discrepancy which the CONTRACTOR may discover and shall obtain a written interpretation or clarification from the ENGINEER before proceeding with any WORK affected thereby.
 - C. The CONTRACTOR shall submit to the ENGINEER for review those documents called for under Section 01300 - Contractor Submittals in the General Requirements.
- 2.5 **PRE-CONSTRUCTION CONFERENCE.** The CONTRACTOR is required to attend a Pre-Construction Conference. This conference will be attended by the ENGINEER and others as appropriate in order to discuss the WORK in accordance with the applicable procedures specified in the General Requirements, Section 01010 - Summary of Work in the General Requirements.

ARTICLE 3 CONTRACT DOCUMENTS: INTENT, AMENDING, REUSE

3.1 INTENT

- A. The Contract Documents comprise the entire Agreement between the OWNER and the CONTRACTOR concerning the WORK. The Contract Documents shall be construed as a whole in accordance with Alaska Law.
- B. It is the intent of the Contract Documents to describe the WORK, functionally complete, to be constructed in accordance with the Contract Documents. Any work, materials, or equipment that may reasonably be inferred from the Contract Documents as being required to produce the intended result shall be supplied whether or not specifically called for. When words or phrases which have a well-known technical or construction industry or trade meaning are used to describe work, materials, or equipment such words or phrases shall be interpreted in accordance with that meaning, unless a definition has been provided in Article 1 of the General Conditions. Reference to standard specifications, manuals, or codes of any technical society, organization, or association, or to the Laws or Regulations of any governmental authority, whether such reference be specific or by implication, shall mean the latest standard specification, manual, code, or Laws or Regulations in effect at the time of opening of Bids, except as may be otherwise specifically stated. However, no provision of any referenced standard specification, manual, or code (whether or not specifically incorporated by reference in the Contract Documents) shall be effective to change the duties and responsibilities of the OWNER,

SECTION 00700 - GENERAL CONDITIONS

the CONTRACTOR, or the ENGINEER or any of their consultants, agents, or employees from those set forth in the Contract Documents.

- C. If, during the performance of the WORK, CONTRACTOR discovers any conflict, error, ambiguity or discrepancy within the Contract Documents or between the Contract Documents and any provision of any such Law or Regulation applicable to the performance of the WORK or of any such standard, specification, manual or code or of any instruction of any Supplier referred to in paragraph 6.5, the CONTRACTOR shall report it to the ENGINEER in writing at once, and the CONTRACTOR shall not proceed with the WORK affected thereby (except in an emergency as authorized by the ENGINEER) until a clarification field order, or Change Order to the Contract Documents has been issued.

3.2 ORDER OF PRECEDENCE OF CONTRACT DOCUMENTS

- A. In resolving conflicts resulting from, errors, or discrepancies in any of the Contract Documents, the order of precedence shall be as follows:

1. Permits from other agencies as may be required by law, excepting the definition of "PERMITEE" in these permits.
2. Field Orders
3. Change Orders
4. ENGINEER's written interpretations and clarifications.
5. Agreement
6. Addenda
7. CONTRACTOR's Bid (Bid Form)
8. Supplementary General Conditions
9. Notice Inviting Bids
10. Instructions to Bidders
11. General Conditions
12. Technical Specifications
13. Drawings

- B. With reference to the Drawings the order of precedence is as follows:

1. Figures govern over scaled dimensions
2. Detail Drawings govern over general Drawings
3. Addenda/ Change Order drawings govern over Contract Drawings
4. Contract Drawings govern over standard drawings

- 3.3 AMENDING AND SUPPLEMENTING CONTRACT DOCUMENTS. The Contract Documents may be amended to provide for additions, deletions, and revisions in the WORK or to modify the terms and conditions thereof by a Change Order (pursuant to Article 10 CHANGES IN THE WORK).

- 3.4 REUSE OF DOCUMENTS. Neither the CONTRACTOR, nor any Subcontractor or Supplier, nor any other person or organization performing any of the WORK under a contract with the OWNER shall have or acquire any title to or ownership rights in any of the Drawings, Technical Specifications, or other documents used on the WORK, and they shall not reuse any of them on the extensions of the Project or any other project without written consent of the OWNER.

SECTION 00700 - GENERAL CONDITIONS

ARTICLE 4 AVAILABILITY OF LANDS; PHYSICAL CONDITIONS; REFERENCE POINTS

4.1 AVAILABILITY OF LANDS. The OWNER shall furnish, as indicated in the Contract Documents, the lands upon which the WORK is to be performed, rights-of-way and easements for access thereto, and such other lands which are designated for the use of the CONTRACTOR. Easements for permanent structures or permanent changes in existing facilities will be obtained and paid for by the OWNER, unless otherwise provided in the Contract Documents. Nothing contained in the Contract Documents shall be interpreted as giving the CONTRACTOR exclusive occupancy of the lands or rights-of-way provided. The CONTRACTOR shall provide for all additional lands and access thereto that may be required for temporary construction facilities or storage of materials and equipment; provided, that the CONTRACTOR shall not enter upon nor use any property not under the control of the OWNER until a written temporary construction easement, lease or other appropriate agreement has been executed by the CONTRACTOR and the property owner, and a copy of said agreement furnished to the ENGINEER prior to said use; and, neither the OWNER nor the ENGINEER shall be liable for any claims or damages resulting from the CONTRACTOR's unauthorized trespass or use of any such properties.

4.2 PHYSICAL CONDITIONS - SUBSURFACE AND EXISTING STRUCTURES

A. Explorations and Reports. Reference is made to SGC 4.2 Physical Conditions of the Supplementary General Conditions for identification of those reports of explorations and tests of sub-surface conditions at the site that have been utilized by the ENGINEER in the preparation of the Contract Documents. The CONTRACTOR may rely upon the accuracy of the technical data contained in such reports, however, reports are not to be considered complete or comprehensive and nontechnical data, interpretations, and opinions contained in such reports shall be verified by the CONTRACTOR prior to bid. The CONTRACTOR is responsible for any further explorations or tests that may be necessary and any interpretation, interpolation, or extrapolation that it makes of any information shown in such reports.

B. Existing Structures. Reference is made to SGC 4.2 Physical Conditions of the Supplementary General Conditions for identification of those drawings of physical conditions in or relating to existing surface and subsurface structures (except Underground Utilities referred to in Paragraph 4.4 herein) which are at or contiguous to the site that have been utilized by the ENGINEER in the preparation of the Contract Documents. The CONTRACTOR may rely upon the accuracy of the technical data contained in such drawings, however, nontechnical data, interpretations, and opinions contained in such drawings shall be verified by the CONTRACTOR prior to bid. The CONTRACTOR is also responsible for any interpretation, interpolation, or extrapolation that it makes of any information shown in such drawings.

4.3 DIFFERING SITE CONDITIONS

A. The CONTRACTOR shall promptly upon discovery (but in no event later than 14 days thereafter) and before the following conditions are disturbed, notify the ENGINEER, in writing of any:

1. Material that the CONTRACTOR believes may be material that is hazardous waste, as defined in Article 1 of these General Conditions, or asbestos, PCB's,

SECTION 00700 - GENERAL CONDITIONS

petroleum or any other substance or material posing a threat to human or to the environment.

2. Subsurface or latent physical conditions at the site differing from those indicated in the reports referenced in SGC 4.2 Physical Conditions.
 3. Unknown physical conditions at the site of any unusual nature, differing materially from those physical conditions ordinarily encountered in the area of project and generally recognized as inherent in the area of the project and as ordinarily encountered and inherent in WORK of the character provided for in the contract. Weather conditions specifically do not constitute any change condition under this section.
- B. The OWNER shall promptly investigate the conditions, and if it finds that the conditions do materially so differ, or do involve hazardous waste, and cause a decrease or increase in the CONTRACTOR's cost of, or the time required for, performance of any part of the WORK shall issue a Change Order under the procedures described in the contract.
- C. In the event that a dispute arises between the OWNER and the CONTRACTOR whether the conditions materially differ, or involved hazardous waste or other materials listed above, or cause a decrease or increase in the CONTRACTOR's cost of, or time required for, performance of any part of the WORK, the CONTRACTOR shall not be excused from any scheduled completion date provided for by the contract, but shall proceed with all WORK to be performed under the contract. The CONTRACTOR and OWNER shall retain any and all rights provided either by contract or by Law which pertain to the resolution of disputes and protests between the contracting parties.

4.4 PHYSICAL CONDITIONS - UNDERGROUND UTILITIES

- A. Indicated. The information and data indicated in the Contract Documents with respect to existing Underground Utilities at or contiguous to the site are based on information and data furnished to the OWNER or the ENGINEER by the owners of such Underground Utilities or by others. Unless it is expressly provided in the Supplementary General Conditions and/or Section 01530 - Protection and Restoration of Existing Facilities of the General Requirements, the OWNER and the ENGINEER shall not be responsible for the accuracy or completeness of any such information or data, and the CONTRACTOR shall have full responsibility for reviewing and checking all such information and data, for locating all Underground Utilities indicated in the Contract Documents, for coordination of the WORK with the owners of such Underground Utilities during construction, for the safety and protection thereof and repairing any damage thereto resulting from the WORK, the cost of which will be considered as having been included in the Contract Price.
- B. Not Indicated. If an Underground Utility is uncovered or revealed at or contiguous to the site which was not indicated in the Contract Documents and which the CONTRACTOR could not reasonably have been expected to be aware of, the CONTRACTOR shall identify the owner of such Underground Utility and give written notice thereof to that owner and shall notify the ENGINEER in accordance with the requirements of the Supplementary General Conditions and Section 01530 - Protection and Restoration of Existing Facilities of the General Requirements.

SECTION 00700 - GENERAL CONDITIONS

4.5 REFERENCE POINTS

- A. The ENGINEER will provide one benchmark, near or on the site of the WORK, and will provide two points near or on the site to establish a base line for use by the CONTRACTOR for alignment control. Unless otherwise specified in the General Requirements, the CONTRACTOR shall furnish all other lines, grades, and benchmarks required for proper execution of the WORK.
- B. The CONTRACTOR shall preserve all bench marks, stakes, and other survey marks, and in case of their removal or destruction by its own employees or by its Subcontractor's employees, the CONTRACTOR shall be responsible for the accurate replacement of such reference points by personnel qualified under the Alaska Statute governing the licensing of Architects, Engineers, and Land Surveyors.

ARTICLE 5 BONDS AND INSURANCE

5.1 PERFORMANCE, PAYMENT, AND OTHER BONDS

- A. The CONTRACTOR shall furnish, when required, Performance and Payment Bonds on forms provided by the OWNER for the penal sums of 100% of the amount of the Bid award. The surety on each bond may be any corporation or partnership authorized to do business in the State of Alaska as an insurer under AS 21.09. These bonds shall remain in effect for 12 months after the date of final payment and until all obligations and liens under this contract have been satisfied. The CONTRACTOR shall also furnish such other Bonds as are required by the Supplementary General Conditions. All Bonds shall be in the form prescribed by the Contract Documents except as provided otherwise by Laws or Regulations, and shall be executed by such sureties as are named in the current list of "Companies Holding Certificates of Authority as Acceptable Sureties on Federal Bonds and as Acceptable Reinsuring Companies" as published in Circular 570 (amended) by the Audit Staff, Bureau of Government Financial Operations, U.S. Treasury Department. All Bonds signed by an agent must be accompanied by a certified copy of such agent's authority to act.
- B. If the surety on any Bond furnished by the CONTRACTOR is declared bankrupt or becomes insolvent or its right to do business is terminated in any state where any part of the WORK is located, the CONTRACTOR shall within 7 days thereafter substitute another Bond and Surety, which must be acceptable to the OWNER.
- C. All Bonds required by the Contract Documents to be purchased and maintained by CONTRACTOR shall be obtained from surety companies that are duly licensed or authorized in the State of Alaska to issue Bonds for the limits so required. Such surety companies shall also meet such additional requirements and qualifications as may be provided in the Supplementary General Conditions. The City Manager may, on behalf of the OWNER, notify the surety of any potential default or liability.

5.2 INSURANCE

- A. The CONTRACTOR shall purchase and maintain the insurance required under this paragraph. Such insurance shall include the specific coverages set out herein and be written for not less than the limits of liability and coverages provided in the Supplementary General Conditions, or required by law, whichever are greater. All

SECTION 00700 - GENERAL CONDITIONS

insurance shall be maintained continuously during the life of the Agreement up to the date of Final Completion and at all times thereafter when the CONTRACTOR may be correcting, removing, or replacing Defective WORK in accordance with Paragraph 13.6, but the CONTRACTOR's liabilities under this Agreement shall not be deemed limited in any way to the insurance coverage required.

- B. All insurance required by the Contract Documents to be purchased and maintained by the CONTRACTOR shall be obtained from insurance companies that are duly licensed or authorized in the State of Alaska to issue insurance policies for the limits and coverages so required. Such insurance companies shall have a current Best's Rating of at least an "A" (Excellent) general policy holder's rating and a Class VII financial size category and shall also meet such additional requirements and qualifications as may be provided in the Supplementary General Conditions.
- C. The City and Borough of Wrangell shall be listed as an additional insured on the CONTRACTOR'S general liability insurance policy and the CONTRACTOR'S pollution liability policy. CONTRACTOR shall furnish certificates to the Borough of such insurance and showing the Borough as an additional insured within ten days of receiving the Notice to Proceed. Failure to comply with this provision constitutes a material breach and default of the Agreement.

ARTICLE 6 CONTRACTOR'S RESPONSIBILITIES

6.1 SUPERVISION AND SUPERINTENDENCE

- A. The CONTRACTOR shall supervise, inspect, and direct the WORK competently and efficiently, devoting such attention thereto and applying such skills and expertise as may be necessary to perform the WORK in accordance with the Contract Documents. The CONTRACTOR shall be solely responsible for the means, methods, techniques, sequences, and procedures of construction and safety precautions and programs incidental thereto. The CONTRACTOR shall be responsible to see that the completed WORK complies accurately with the Contract Documents.
- B. The CONTRACTOR shall designate in writing and keep on the WORK site at all times during its progress a technically qualified, English-speaking superintendent, who is an employee of the CONTRACTOR and who shall not be replaced without written notice to the OWNER and the ENGINEER. The superintendent will be the CONTRACTOR's representative at the site and shall have authority to act on behalf of the CONTRACTOR. All communications given to the superintendent shall be as binding as if given to the CONTRACTOR. The CONTRACTOR shall issue all its communications to the OWNER through the ENGINEER and the ENGINEER only.
- C. The CONTRACTOR's superintendent shall be present at the site of the WORK at all times while WORK is in progress. Failure to observe this requirement shall be considered suspension of the WORK by the CONTRACTOR until such time as such superintendent is again present at the site.

SECTION 00700 - GENERAL CONDITIONS

6.2 LABOR, MATERIALS, AND EQUIPMENT

- A. The CONTRACTOR shall provide competent, suitably qualified personnel to survey and lay out the WORK and perform construction as required by the Contract Documents. The CONTRACTOR shall furnish, erect, maintain, and remove the construction plant and any temporary works as may be required. The CONTRACTOR shall at all times maintain good discipline and order at the site. Except in connection with the safety or protection of persons or the WORK or property at the site or adjacent thereto, and except as otherwise indicated in the Contract Documents, all WORK at the site shall be performed during regular working hours, and the CONTRACTOR will not permit overtime work or the performance of work on Saturday, Sunday, or any legal holiday without the OWNER's written consent. The CONTRACTOR shall apply for this consent through the ENGINEER.
- B. Except as otherwise provided in this Paragraph, the CONTRACTOR shall receive no additional compensation for overtime work, i.e., work in excess of 8 hours in any one calendar day or 40 hours in any one calendar week, even though such overtime work may be required under emergency conditions and may be ordered by the ENGINEER in writing. Additional compensation will be paid the CONTRACTOR for overtime work only in the event extra work is ordered by the ENGINEER and the Change Order specifically authorizes the use of overtime work and then only to such extent as overtime wages are regularly being paid by the CONTRACTOR for overtime work of a similar nature in the same locality.
- C. All costs of inspection and testing performed during overtime work by the CONTRACTOR which is allowed solely for the convenience of the CONTRACTOR shall be borne by the CONTRACTOR. The OWNER shall have the authority to deduct the cost of all such inspection and testing from any partial payments otherwise due to the CONTRACTOR.
- D. Unless otherwise specified in the Contract Documents, the CONTRACTOR shall furnish and assume full responsibility for all materials, equipment, labor, transportation, construction equipment and machinery, tools, appliances, fuel, power, light, heat, telephone, water, sanitary facilities, and all other facilities and incidentals necessary for the furnishing, performance, testing, start-up, and completion of the WORK, including all mobilization and demobilization.
- E. All materials and equipment to be incorporated into the WORK shall be of good quality and new, except as otherwise provided in the Contract Documents. All warranties and guarantees specifically called for by the Specifications shall expressly run to the benefit of the OWNER. If required by the ENGINEER, the CONTRACTOR shall furnish satisfactory evidence (including reports of required tests) as to the kind and quality of materials and equipment. All materials and equipment shall be applied, installed, connected, erected, used, cleaned, and conditioned in accordance with the instructions of the applicable Supplier except as otherwise provided in the Contract Documents; but no provisions of any such instructions will be effective to assign to the ENGINEER, or any of the ENGINEER consultants, agents, or employees, any duty or authority to supervise or direct the furnishing or performance of the WORK or any duty or authority to undertake responsibility contrary to the provisions of Paragraphs 9.9C and 9.9D.

SECTION 00700 - GENERAL CONDITIONS

- F. The CONTRACTOR shall at all times employ sufficient labor and equipment for prosecuting the several classes of WORK to full completion in the manner and time set forth in and required by these specifications. All workers shall have sufficient skill and experience to perform properly the WORK assigned to them. Workers engaged in special WORK, or skilled WORK, shall have sufficient experience in such WORK and in the operation of the equipment required to perform all WORK, properly and satisfactorily.
- G. Any person employed by the CONTRACTOR or by any Subcontractor who, in the opinion of the ENGINEER, does not perform the WORK in a proper and skillful manner, or is intemperate or disorderly shall, at the written request of the ENGINEER, be removed forthwith by the CONTRACTOR or Subcontractor employing such person, and shall not be employed again in any portion of the WORK without the approval of the ENGINEER. Should the CONTRACTOR fail to remove such person or persons as required above, or fail to furnish suitable and sufficient personnel for the proper prosecution of the WORK, the ENGINEER may suspend the WORK by written notice until such orders are complied with.
- 6.3 ADJUSTING PROGRESS SCHEDULE. The CONTRACTOR shall submit monthly updates of the progress schedule to the ENGINEER for acceptance in accordance with the provisions in Section 01300 - Contractor Submittals in the General Requirements.
- 6.4 SUBSTITUTES OR "OR-EQUAL" ITEMS. The CONTRACTOR shall submit proposed substitutes or "or-equal" items in accordance with the provisions in Section 01300 - Contractor Submittals in the General Requirements.
- 6.5 CONCERNING SUBCONTRACTORS, SUPPLIERS, AND OTHERS.
- A. The CONTRACTOR shall be responsible to the OWNER and the ENGINEER for the acts and omissions of its Subcontractors and their employees to the same extent as CONTRACTOR is responsible for the acts and omissions of its own employees. Nothing contained in this Paragraph shall create any contractual relationship between any Subcontractor and the OWNER or the ENGINEER nor relieve the CONTRACTOR of any liability or obligation under the Agreement and Contract documents.
- B. The CONTRACTOR shall perform not less than 40% of the WORK with its own forces (i.e., without subcontracting). The 40% requirement shall be understood to mean that the CONTRACTOR shall perform, with its own organization, WORK amounting to at least 40% of the awarded contract amount. The 40% requirement will be calculated based upon the total of the subcontract amounts submitted for contract award, and any other information requested by the OWNER from the apparent low bidder.
- 6.6 PERMITS
- A. Unless otherwise provided in the Supplementary General Conditions, the CONTRACTOR shall obtain and pay for all construction permits and licenses from the agencies having jurisdiction, including the furnishing of insurance and bonds if required by such agencies. The enforcement of such requirements under this contract shall not be made the basis for claims for additional compensation. The OWNER shall assist the CONTRACTOR, when necessary, in obtaining such permits and licenses. The CONTRACTOR shall pay all governmental charges and inspection fees necessary for the

SECTION 00700 - GENERAL CONDITIONS

prosecution of the WORK, which are applicable at the time of opening of Bids. The CONTRACTOR shall pay all charges of utility owners for connections to the WORK.

- B. These Contract Documents may require that the WORK be performed within the conditions and/or requirements of local, state and/or federal permits. These permits may be bound within the Contract Documents, included within the Contract Documents by reference, or included as part of the WORK, as designated in this Section. The CONTRACTOR is responsible for completing the WORK required for compliance with all permit requirements; this WORK is incidental to other items in the Contract Documents. Any reference to the “permittee” in the permits shall mean the CONTRACTOR. If any permits were acquired by the OWNER, this action was done to expedite the start of construction. If the CONTRACTOR does not complete the WORK within the specified permit window, the CONTRACTOR shall be responsible for the permit extension, and for completing any additional requirements placed upon the permit.
- C. These Contract Documents may require that the WORK be performed within the conditions and/or requirements of local, state and/or federal permits. These permits may be bound within the Contract Documents, included within the Contract Documents by reference, or included as part of the WORK, as designated in Section 00700 – General Conditions, Article 6.6 - PERMITS. The CONTRACTOR is responsible for completing the WORK required for compliance with all permit requirements; this WORK is incidental to other items in the Contract Documents. Any reference to the “permittee” in the permits shall mean the CONTRACTOR. If any permits were acquired by the OWNER, this action was done to expedite the start of construction. If the CONTRACTOR does not complete the WORK within the specified permit window, the CONTRACTOR shall be responsible for the permit extension, and for completing any additional requirements placed upon the permit.
- D. The OWNER shall apply for, and obtain, the necessary building permit for this project, however, the CONTRACTOR is responsible for scheduling and coordinating all necessary inspections. All other provisions of this Section remain in effect.
- 6.7 PATENT FEES AND ROYALTIES. The CONTRACTOR shall pay all license fees and royalties and assume all costs incident to the use in the performance of the WORK or the incorporation in the WORK of any invention, design, process, product, software or device which is the subject of patent rights or copyrights held by others. If a particular invention, design, process, product, or device is specified in the Contract Documents for use in the performance of the WORK and if to the actual knowledge of the OWNER or the ENGINEER its use is subject to patent rights or copyrights calling for the payment of any license fee or royalty to others, the existence of such rights shall be disclosed by the OWNER in the Contract Documents. The CONTRACTOR shall indemnify, defend and hold harmless the OWNER and the ENGINEER and anyone directly or indirectly employed by either of them from and against all claims, damages, losses, and expenses (including attorneys’ fees and court costs) arising out of any infringement of patent rights or copyrights incident to the use in the performance of the WORK or resulting from the incorporation in the WORK of any invention, design, process, product, or device not specified in the Contract Documents, and shall defend all such claims in connection with any alleged infringement of such rights.
- 6.8 LAWS AND REGULATIONS. The CONTRACTOR shall observe and comply with all federal, state, and local laws, ordinances, codes, orders, and regulations which in any manner affect those engaged or employed on the WORK, the materials used in the WORK, or the conduct of the

SECTION 00700 - GENERAL CONDITIONS

WORK. If any discrepancy or inconsistency should be discovered in this contract in relation to any such law, ordinance, code, order, or regulation, the CONTRACTOR shall report the same in writing to the ENGINEER. The CONTRACTOR shall indemnify, defend, and hold harmless the OWNER, the ENGINEER, and their officers, agents, and employees against all claims or liability arising from violation of any such law, ordinance, code, order, or regulation, whether by CONTRACTOR or by its employees, Subcontractors, or third parties. Any particular law or regulation specified or referred to elsewhere in the Contract Documents shall not in any way limit the obligation of the CONTRACTOR to comply with all other provisions of federal, state, and local laws and regulations.

The OWNER may, per AS 36.30, audit the CONTRACTOR's or Subcontractor(s) records that are related to the cost or pricing data for this contract, all related Change Orders, and/or contract modifications.

6.9 TAXES. The CONTRACTOR shall pay all sales, consumer, use, and other similar taxes required to be paid by the CONTRACTOR in accordance with the Laws and Regulations of the place of the Project which are applicable during the performance of the WORK.

6.10 USE OF PREMISES. The CONTRACTOR shall confine construction equipment, the storage of materials and equipment, and the operations of workers to (1) the Project site, (2) the land and areas identified in and permitted by the Contract Documents, and (3) the other land and areas permitted by Laws and Regulations, rights-of-way, permits, leases and easements. The CONTRACTOR shall assume full responsibility for any damage to any such land or area, or to the owner or occupant thereof or of any land or areas contiguous thereto, resulting from the performance of the WORK. Should any claim be made against the OWNER or the ENGINEER by any such owner or occupant because of the performance of the WORK, the CONTRACTOR shall promptly attempt to settle with such other party by agreement or otherwise resolve the claim through litigation. The CONTRACTOR shall, to the fullest extent permitted by Laws and Regulations, indemnify, defend, and hold the OWNER and the ENGINEER harmless from and against all claims, damages, losses, and expenses (including, but not limited to, fees of engineers attorneys, and other professionals and court costs) arising directly, indirectly, or consequentially out of any action, legal or equitable, brought by any such owner or occupant against the OWNER, the ENGINEER, their Consultants, Sub-consultants, and the officers, directors, employees and agents of each and any of them to the extent caused by or based upon the CONTRACTOR's performance or non-performance of the WORK.

6.11 SAFETY AND PROTECTION

A. The CONTRACTOR shall be responsible for initiating, maintaining, and supervising all safety precautions and programs in connection with the WORK. The CONTRACTOR shall take all necessary precautions for the safety of, and shall provide the necessary protection to prevent damage, injury or loss to:

1. all employees on the WORK and other persons and organizations who may be affected thereby;
2. all the WORK and materials and equipment to be incorporated therein, whether in storage on or off the site; and
3. other property at the site or adjacent thereto, including trees, shrubs, lawns, walks, pavements, roadways, structures, and utilities not designated for removal, relocation, or replacement in the course of construction.

SECTION 00700 - GENERAL CONDITIONS

- B. The CONTRACTOR shall comply with all applicable Laws and Regulations whether referred to herein or not) of any public body having jurisdiction for the safety of persons or property or to protect them from damage, injury, or loss and shall erect and maintain all necessary safeguards for such safety and protection. The CONTRACTOR shall notify owners of adjacent property and utilities when prosecution of the WORK may affect them, and shall cooperate with them in the protection, removal, relocation, and replacement of their property.
- C. The CONTRACTOR shall designate a qualified and experienced safety representative at the site whose duties and responsibilities shall be the prevention of accidents and the maintaining and supervising of safety precautions and program.
- D. Materials that contain hazardous substances or mixtures may be required on the WORK. A Material Safety Data Sheet shall be requested by the CONTRACTOR from the manufacturer of any hazardous product used.
- E. Material usage shall be accomplished with strict adherence to all safety requirements and all manufacturer's warnings and application instructions listed on the Material Safety Data Sheet and on the product container label.
- F. The CONTRACTOR shall be responsible for coordinating communications on any exchange of Material Safety Data Sheets or other hazardous material information that is required to be made available to, or exchanged between, or among, employers at the site in accordance with Laws or Regulations.
- G. The CONTRACTOR shall notify the ENGINEER if it considers a specified product or its intended usage to be unsafe. This notification must be given to the ENGINEER prior to the product being ordered, or if provided by some other party, prior to the product being incorporated in the WORK.

6.12 SHOP DRAWINGS AND SAMPLES

- A. After checking and verifying all field measurements and after complying with applicable procedures specified in the General Requirements, the CONTRACTOR shall submit to the ENGINEER for review, all Shop Drawings in accordance with Section 01300 - Contractor Submittals in the General Requirements.
- B. The Contractor shall also submit to the ENGINEER for review all samples in accordance with Section 01300 - Contractor Submittals in the General Requirements.
- C. Before submittal of each shop drawing or sample, the CONTRACTOR shall have determined and verified all quantities, dimensions, specified performance criteria, installation requirements, materials, catalog numbers, and similar data with respect thereto and reviewed or coordinated each Shop Drawing or sample with other Shop Drawings and samples and with the requirements of the WORK and the Contract Documents.

- 6.13 CONTINUING THE WORK. The CONTRACTOR shall carry on the WORK and adhere to the progress schedule during all disputes or disagreements with the OWNER. No work shall be delayed or postponed pending resolution of any disputes or disagreements, except as the CONTRACTOR and the OWNER may otherwise agree in writing.

SECTION 00700 - GENERAL CONDITIONS

6.14 INDEMNIFICATION

- A. To the fullest extent permitted by the laws of the State of Alaska, the CONTRACTOR shall indemnify, defend, and hold harmless the OWNER, the ENGINEER, their Consultants, Sub-consultants and the officers, assembly members, mayor, directors, employees, and agents of each and any of them, against and from all claims, actions, damages, and liability of any kind and any nature arising out of or related to in way any acts or omissions of the CONTRACTOR, including death, and including in any administrative action by any federal or state agency, except where the claim or action alleges willful misconduct of the OWNER and the ENGINEER. Such indemnification by the CONTRACTOR shall include but not be limited to the following:
1. Liability or claims resulting directly or indirectly from the negligence or carelessness of the CONTRACTOR, its employees, or agents in the performance of the WORK, or non-performance of the WORK, or in guarding or maintaining the same, or from any improper materials, implements, or appliances used in its construction, or by or on account of any act or omission of the CONTRACTOR, its employees, agents, or third parties;
 2. Liability or claims arising directly or indirectly from bodily injury, occupational sickness or disease, or death of the CONTRACTOR's or Subcontractor's own employees engaged in the WORK resulting in actions brought by or on behalf of such employees against the OWNER, and the ENGINEER;
 3. Liability or claims arising directly or indirectly from or based on the violation of any federal, state or local law, ordinance, regulation, order, or decree, whether by the CONTRACTOR, its employees, or agents;
 4. Liability or claims arising directly or indirectly from the use or manufacture by the CONTRACTOR, its employees, or agents in the performance of this contract of any copyrighted or non-copyrighted composition, secret process, patented or non-patented invention, computer software, article, or appliance, unless otherwise specifically stipulated in this contract.
 5. Liability or claims arising directly or indirectly from the breach of any warranties, whether express or implied, made to the OWNER or any other parties by the CONTRACTOR, its employees, or agents;
 6. Liabilities or claims arising directly or indirectly from the willful or criminal misconduct of the CONTRACTOR, its employees, or agents; and,
 7. Liabilities or claims arising directly or indirectly from any breach of the obligations of the CONTRACTOR in the Agreement and all Contract documents.
- B. The CONTRACTOR shall reimburse the ENGINEER and the OWNER for all costs and expenses, (including but not limited to fees and charges of engineers, attorneys, experts, and other professionals and court costs including all costs of appeals) incurred by the OWNER, and the ENGINEER in enforcing the provisions of this Paragraph 6.14.
- C. The indemnification obligation under this Paragraph 6.14 shall not be limited in any way by any limitation of the amount or type of damages, compensation, or benefits payable by or for the CONTRACTOR or any such Subcontractor or other person or organization under workers' compensation acts, disability benefit acts, or other employee benefit acts.

6.15 CONTRACTOR'S DAILY REPORTS. The CONTRACTOR shall complete a daily report indicating total manpower for each construction trade, major equipment on site, each

SECTION 00700 - GENERAL CONDITIONS

Subcontractor's manpower, weather conditions, etc., involved in the performance of the WORK. The daily report shall be completed on forms provided by the ENGINEER and shall be submitted to the ENGINEER at the conclusion of each workday. The report should comment on the daily progress and status of the WORK within each major component of the WORK. These components will be decided by the ENGINEER.

- 6.16 ASSIGNMENT OF CONTRACT. The CONTRACTOR shall not assign, sublet, sell, transfer, or otherwise dispose of the contract or any portion thereof, or its right, title, or interest therein, or obligations thereunder, without the written consent of the OWNER except as imposed by law. If the CONTRACTOR violates this provision, the contract may be terminated at the sole option of the OWNER. In such event, the OWNER shall be relieved of all liability and obligations to the CONTRACTOR and to its assignee or transferee, growing out of such termination.
- 6.17 CONTRACTOR'S RESPONSIBILITY FOR UTILITY PROPERTY AND SERVICES. It is understood that any turn-on or turn-off, line locates and any other work or assistance necessary by the OWNER, will be at the CONTRACTOR's expense unless otherwise stated in the bid documents. All cost must be agreed to prior to any related actions and will be considered incidental to the project cost. Billing to the CONTRACTOR will be direct from the OWNER.
- 6.18 OPERATING WATER SYSTEM VALVES
- A. The CONTRACTOR shall submit a written request, to the ENGINEER, for approval to operate any valve on any in-service section of the City water system. The request must be submitted at least 24-hours prior to operating any valves. The request shall specifically identify each valve to be operated, the time of operation, and the operation to be performed. The CONTRACTOR shall obtain the written approval of the ENGINEER for any scheduled operation before operating any valve.
- B. The CONTRACTOR shall be responsible for all damages, both direct and consequential, to the OWNER or any other party, caused by unauthorized operation of any valve of the City water system.
- 6.19 CONTRACTOR'S WORK SCHEDULE LIMITATIONS. City and Borough of Wrangell Noise Ordinance. The noise loudness measured at the boundary line of the premises used for industrial activities shall not exceed 90 decibels between the hours of 7:00 AM and 8:00 PM on weekdays and the hours of 10:00 AM and 8:00 PM on weekends and holidays, and 40 decibels at other hours, unless a permit shall first be obtained from the OWNER. Such permit shall be issued by the OWNER only upon a determination that such operation during hours not otherwise permitted hereunder is necessary and will not result in unreasonable disturbance to surrounding residents.

ARTICLE 7 OTHER WORK

7.1 RELATED WORK AT SITE

- A. The OWNER may perform other work related to the Project at the site by the OWNER's own forces, have other work performed by utility owners, or let other direct contracts therefor which may contain General Conditions similar to these. If the fact that such other work is to be performed was not noted in the Contract Documents, written notice thereof will be given to the CONTRACTOR prior to starting any such other work.

SECTION 00700 - GENERAL CONDITIONS

- B. The CONTRACTOR shall afford each other contractor who is a party to such a direct contract and each utility owner (or the OWNER, if the OWNER is performing the additional work with the OWNER's employees) proper and safe access to the site and a reasonable opportunity for the introduction and storage of materials and equipment and the execution of such work, and shall properly connect and coordinate the WORK with theirs. The CONTRACTOR shall do all cutting, fitting, and patching of the WORK that may be required to make its several parts come together properly and integrate with such other work. The CONTRACTOR shall not endanger any work of others by cutting, excavating, or otherwise altering their work and will only cut or alter their work with the written consent of the ENGINEER and the others whose work will be affected.
- C. If the proper execution or results of any part of the CONTRACTOR's WORK depends upon the work of any such other contractor or utility owner (or OWNER), the CONTRACTOR shall inspect and report to the ENGINEER in writing any delays, defects, or deficiencies in such other work that render it unavailable or unsuitable for such proper execution and results. The CONTRACTOR's failure to report such delays, defects, or deficiencies will constitute an acceptance of the other work as fit and proper for integration with the CONTRACTOR's WORK except for latent or nonapparent defects and deficiencies in the other work.

7.2 COORDINATION. If the OWNER contracts with others for the performance of other work on the Project at the site, the person or organization who will have authority and responsibility for coordination of the activities among the various prime contractors will be identified in the Supplementary General Conditions, and the specific matters to be covered by such authority and responsibility will be itemized and the extent of such authority and responsibilities will be provided in the Supplementary General Conditions.

ARTICLE 8 OWNER'S RESPONSIBILITIES

8.1 COMMUNICATIONS

- A. The OWNER shall issue all its communications to the CONTRACTOR through the ENGINEER.
- B. The CONTRACTOR shall issue all its communications to the OWNER through the ENGINEER.

8.2 PAYMENTS. The OWNER shall make payments to the CONTRACTOR as provided in Paragraphs 14.5, 14.8, 14.9 and 14.10.

8.3 LANDS, EASEMENTS, AND SURVEYS. The OWNER's duties in respect of providing lands and easements and providing surveys to establish reference points are set forth in Paragraphs 4.1 and 4.5.

8.4 CHANGE ORDERS. The OWNER shall execute Change Orders as indicated in Paragraph 10.1F.

8.5 INSPECTIONS AND TESTS. The OWNER's responsibility in respect of inspections, tests, and approvals is set forth in Paragraph 13.3.

8.6 SUSPENSION OF WORK. In connection with the OWNER's right to stop WORK or suspend WORK, see Paragraphs 13.4 and 15.1.

SECTION 00700 - GENERAL CONDITIONS

- 8.7 TERMINATION OF AGREEMENT. Paragraphs 15.2 and 15.3 detail the OWNER's right to terminate services of the CONTRACTOR.

ARTICLE 9 ENGINEER'S STATUS DURING CONSTRUCTION

- 9.1 OWNER'S REPRESENTATIVE. The ENGINEER will be the OWNER's representative during the construction period. The duties and responsibilities and the limitations of authority of the ENGINEER as the OWNER's representative during construction are set forth in the Contract Documents.
- 9.2 VISITS TO SITE. The ENGINEER will make visits to the site during construction to observe the progress and quality of the WORK and to determine, in general, if the WORK is proceeding in accordance with the Contract Documents. Exhaustive or continuous on-site inspections to check the quality or quantity of the WORK will not be required of the ENGINEER. The ENGINEER will not, during such visits, or as a result of such observations of the CONTRACTOR's WORK in progress, supervise, direct, or have control over the CONTRACTOR's WORK.
- 9.3 PROJECT REPRESENTATION. The ENGINEER may furnish an Inspector to assist in observing the performance of the WORK. The duties, responsibilities, and limitations of authority are as follows:

A. Duties, Responsibilities and Limitations of Authority of Inspector

General. The Inspector, who is the ENGINEER's Agent, will act as directed by and under the supervision of the ENGINEER and will confer with the ENGINEER regarding its actions. The Inspector's dealings in matters pertaining to the on-site WORK shall, in general, be only with the ENGINEER and the CONTRACTOR, and dealings with Subcontractors shall only be through or with the full knowledge of the CONTRACTOR. Written communication with the OWNER will be only through or as directed by the ENGINEER.

Duties and Responsibilities. The Inspector will:

1. Review the progress schedule, list of Shop Drawing submittals and schedule of values prepared by the CONTRACTOR and consult with the ENGINEER concerning their acceptability.
2. Attend pre-construction conferences. Arrange a schedule of progress meetings and other job conferences as required in consultation with the ENGINEER and notify those expected to attend in advance. Attend meetings and maintain and circulate copies of minutes thereof.
3. Serve as the ENGINEER's liaison with the CONTRACTOR, working principally through the CONTRACTOR's superintendent and assist said superintendent in understanding the intent of the Contract Documents. Assist the ENGINEER in serving as the OWNER's liaison with the CONTRACTOR when the CONTRACTOR's operations affect the OWNER's on-site operations.
4. As requested by the ENGINEER, assist in obtaining from the OWNER additional details or information, when required at the site for proper execution of the WORK.
5. Receive and record date of receipt of Shop Drawings and samples, receive samples which are furnished at the site by the CONTRACTOR and notify the ENGINEER of their availability for examination.

SECTION 00700 - GENERAL CONDITIONS

6. Conduct on-site observations of the WORK in progress to assist the ENGINEER in determining if the WORK is proceeding in accordance with the Contract Documents.
7. Report to the ENGINEER whenever the Inspector believes that any WORK is unsatisfactory, faulty, or defective or does not conform to the Contract Documents, or does not meet the requirements of any inspection, tests or approval required to be made or has been damaged prior to final payment; and advise the ENGINEER when the Inspector believes WORK should be corrected or rejected or should be uncovered for observation, or requires special testing, inspection, or approval.
8. Verify that the tests, equipment, and systems startups and operating and maintenance instruction are conducted as required by the Contract Documents and in presence of the required personnel, and that the CONTRACTOR maintains adequate records thereof; observe, record and report to the ENGINEER appropriate details relative to the test procedures and start-ups.
9. Accompany visiting inspectors representing public or other agencies having jurisdiction over the WORK, record the outcome of these inspections, and report to the ENGINEER.
10. Transmit to the CONTRACTOR the ENGINEER's clarifications and interpretations of the Contract Documents.
11. Consider and evaluate the CONTRACTOR's suggestions for modifications in the Contract Documents and report them with recommendations to the ENGINEER.
12. Maintain at the job site orderly files for correspondence, reports of job conferences, Shop Drawings and sample submittals, reproductions of original Contract Documents including all addenda, Change Orders, field orders, additional Drawings issued subsequent to the execution of the contract, the ENGINEER's clarifications and interpretations of the Contract Documents, progress reports, and other related documents.
13. Keep a diary or log book, recording hours on the job site, weather conditions, data relative to questions of extras or deductions, list all project visitors, daily activities, decisions, observations in general, and specific observations in more detail as in the case of performing and observing test procedures. Send copies to the ENGINEER.
14. Record names, addresses, and telephone numbers of the CONTRACTOR, Subcontractors, and major suppliers of materials and equipment.
15. Furnish the ENGINEER with periodic reports as required of progress of the WORK and the CONTRACTOR's compliance with the accepted progress schedule and schedule of CONTRACTOR submittals.
16. Consult with the ENGINEER in advance of scheduled major tests, inspections, or start of important phases of the WORK.
17. Report immediately to the ENGINEER upon the occurrence of any accident.
18. Review applications for payment with the CONTRACTOR for compliance with the established procedure for their submittal and forward them with recommendations to the ENGINEER, noting particularly their relation to the schedule of values, WORK completed, and materials and equipment delivered at the site but not incorporated in the WORK.
19. During the course of the WORK, verify that certificates, maintenance and operation manuals, and other data required to be assembled and furnished by the CONTRACTOR are applicable to the items actually installed; and deliver this material to the ENGINEER for its review and forwarding to the OWNER prior to final acceptance of the WORK.

SECTION 00700 - GENERAL CONDITIONS

20. Before the ENGINEER prepares a Certificate of Substantial Completion/Notice of completion, as applicable, review the CONTRACTOR's punch list items requiring completion or correction and add any items that CONTRACTOR has omitted.
21. Conduct final inspection in the company of the ENGINEER, the OWNER, and the CONTRACTOR, and prepare a final punch list of items to be completed or corrected.
22. Verify that all items on the punch list have been completed or corrected and make recommendations to the ENGINEER concerning acceptance.

Limitations of Authority. Except upon written instruction of the ENGINEER, the Inspector:

1. Shall not authorize any deviation from the Contract Documents or approve any substitute material or equipment.
2. Shall not exceed limitations on the ENGINEER's authority as set forth in the Contract Documents.
3. Shall not undertake any of the responsibilities of the CONTRACTOR, Subcontractors or CONTRACTOR's superintendent, or expedite the WORK.
4. Shall not advise on or issue directions relative to any aspect of the means, methods, techniques, sequences, or procedures of construction unless such is specifically called for in the Contract Documents.
5. Shall not advise on or issue directions as to safety precautions and programs in connection with the WORK.

9.4 CLARIFICATIONS AND INTERPRETATIONS. The ENGINEER will issue with reasonable promptness such written clarifications or interpretations of the requirements of the Contract Documents (in the form of Drawings or otherwise) as the ENGINEER may determine necessary, which shall be consistent with, or reasonably inferred from, the overall intent of the Contract Documents.

9.5 AUTHORIZED VARIATIONS IN WORK. The ENGINEER may authorize variations in the WORK from the requirements of the Contract Documents. These may be accomplished by a Field Order and will require the CONTRACTOR to perform the WORK involved in a manner that minimizes the impact to the WORK and the contract completion date. If the CONTRACTOR believes that a Field Order justifies an increase in the Contract Price or an extension of the Contract Time, the CONTRACTOR may make a claim therefor as provided in Article 11 or 12.

9.6 REJECTING DEFECTIVE WORK. The ENGINEER will have authority to reject WORK which the ENGINEER believes to be defective and will also have authority to require special inspection or testing of the WORK as provided in Paragraph 13.3G, whether or not the WORK is fabricated, installed, or completed.

9.7 CONTRACTOR SUBMITTALS, CHANGE ORDERS, AND PAYMENTS

- A. In accordance with the procedures set forth in the General Requirements, the ENGINEER will review all CONTRACTOR submittals, including Shop Drawings, samples, substitutes, or "or equal" items, etc., in order to determine if the items covered by the submittals will, after installation or incorporation in the WORK, conform to the requirements of the Contract Documents and be compatible with the design concept of the completed project as a functioning whole as indicated by the Contract Documents.

SECTION 00700 - GENERAL CONDITIONS

The ENGINEER's review will not extend to means, methods, techniques, sequences or procedures of construction or to safety precautions or programs incident thereto.

- B. In connection with the ENGINEER's responsibilities as to Change Orders, see Articles 10, 11, and 12.
- C. In connection with the ENGINEER's responsibilities in respect of Applications for Payment, see Article 14.

9.8 DECISIONS ON DISPUTES

- A. The ENGINEER will be the initial interpreter of the requirements of the Contract Documents and judge of the acceptability of the WORK thereunder. Claims, disputes, and other matters relating to the acceptability of the WORK; the interpretation of the requirements of the Contract Documents pertaining to the performance of the WORK; and those claims under Articles 11 and 12 in respect to changes in the Contract Price or Contract Time will be referred initially to the ENGINEER in writing with a request for formal decision in accordance with this paragraph, which the ENGINEER will render in writing within 30 days of receipt of the request. Written notice of each such claim, dispute, and other matter will be delivered by the CONTRACTOR to the ENGINEER promptly (but in no event later than 30 days) after the occurrence of the event giving rise thereto. Written supporting data will be submitted to the ENGINEER within 60 days after such occurrence unless the ENGINEER allows an additional period of time to ascertain more accurate data in support of the claim. The failure of the CONTRACTOR to provide all supporting documentation for the claim shall result in the denial of the claim and the waiver of the claim by the CONTRACTOR.
- B. The rendering of a decision by the ENGINEER with respect to any such claim, dispute, or other matter (except any which have been waived by the making or acceptance of final payment as provided in Paragraph 14.12) will be a condition precedent to any exercise by the OWNER or the CONTRACTOR of such rights or remedies as either may otherwise have under the Contract Documents or by Law or Regulations in respect of any such claim, dispute, or other matter.

9.9 LIMITATION ON ENGINEER'S RESPONSIBILITIES

- A. Neither the ENGINEER's authority to act under this Article or other provisions of the Contract Documents nor any decision made by the ENGINEER in good faith either to exercise or not exercise such authority shall give rise to any duty or responsibility of the ENGINEER to the CONTRACTOR, any Subcontractor, any Supplier, any surety for any of them, or any other person or organization performing any of the WORK.
- B. Whenever in the Contract Documents the terms "as ordered," "as directed," "as required," "as allowed," "as reviewed," "as approved," or terms of like effect or import are used, or the adjectives "reasonable," "suitable," "acceptable," "proper," or "satisfactory" or adjectives of like effect or import are used to describe a requirement, direction, review, or judgment of the ENGINEER as to the WORK, it is intended that such requirement, direction, review, or judgment will be solely to evaluate the WORK for compliance with the requirements of the Contract Documents, and conformance with the design concept of the completed Project as a functioning whole as indicated by the Contract Documents, unless there is a specific statement indicating otherwise. The use of

SECTION 00700 - GENERAL CONDITIONS

any such term or adjective shall not be effective to assign to the ENGINEER any duty or authority to supervise or direct the performance of the WORK or any duty or authority to undertake responsibility contrary to the provisions of Paragraph 9.9C or 9.9D.

- C. The ENGINEER will not supervise, direct, control, or have authority over or be responsible for the CONTRACTOR's means, methods, techniques, sequences, or procedures of construction, or the safety precautions and programs incident thereto, or for any failure of the CONTRACTOR to comply with Laws and Regulations, applicable to the performance of the WORK. The ENGINEER will not be responsible for the CONTRACTOR's failure to perform the WORK in accordance with the Contract Documents, except where the failure of the CONTRACTOR is the result of negligent acts or omissions of the ENGINEER in the ENGINEER's performance of its obligations.
- D. The ENGINEER will not be responsible for the acts or omissions of the CONTRACTOR nor of any Subcontractor, supplier, or any other person or organization performing any of the WORK.

ARTICLE 10 CHANGES IN THE WORK

10.1 GENERAL

- A. Without invalidating the Agreement and without notice to any surety, the OWNER may at any time or from time to time, order additions, deletions, or revisions in the WORK; these will be authorized by a written Field Order and/or a Change Order issued by the ENGINEER.
- B. If the CONTRACTOR believes that it is entitled to an increase or decrease in the Contract Price, or an extension or shortening in the Contract Time as the result of a Field Order, a claim may be made as provided in Articles 11 and 12.
- C. If the OWNER and CONTRACTOR agree on the value of any work, or the amount of Contract Time that should be allowed as a result of a Field Order, upon receiving written notice from the ENGINEER, the CONTRACTOR shall proceed so as to minimize the impact on and delays to the work pending the issuance of a Change Order.
- D. If the OWNER and the CONTRACTOR are unable to agree as to the extent, if any, of an increase or decrease in the Contract Price or an extension or shortening of the Contract Time that should be allowed as a result of a Field Order, the ENGINEER can direct the CONTRACTOR to proceed on the basis of Time and Materials so as to minimize the impact on and delays to WORK, and a claim may be made therefor as provided in Articles 11 and 12.
- E. The CONTRACTOR shall not be entitled to an increase in the Contract Price nor an extension of the Contract Time with respect to any work performed that is not required by the Contract Documents as amended, modified, supplemented by Change Order, except in the case of an emergency and except in the case of uncovering work as provided in Paragraph 13.3G.
- F. The OWNER and the CONTRACTOR shall execute appropriate Change Orders covering:

SECTION 00700 - GENERAL CONDITIONS

1. changes in the WORK which are ordered by the OWNER pursuant to Paragraph 10.1A;
 2. changes required because of acceptance of Defective WORK under Paragraph 13.7;
 3. changes in the Contract Price or Contract Time which are agreed to by the parties; or
 4. changes in the Contract Price or Contract Times which embody the substance of any written decision rendered by the ENGINEER pursuant to Paragraph 9.8.
- G. If notice of any change is required by the provisions of any Bond to be given to a surety, the giving of any such notice will be the CONTRACTOR's responsibility, and the amount of each applicable Bond shall be adjusted accordingly.

10.2 ALLOWABLE QUANTITY VARIATIONS

- A. In the event of an increase or decrease in Bid item quantity of a unit price contract, the total amount of WORK actually done or materials or equipment furnished shall be paid for according to the unit bid price established for such WORK under the Contract Documents, wherever such unit price has been established; provided, that an adjustment in the Contract Price may be made for changes which result in an increase or decrease in excess of 25% of the estimated quantity of any major item of the WORK. Major Item is defined as any bid item amount that is ten percent (10%) or more of the total contract amount.
- B. In the event a part of the WORK is to be entirely eliminated and no lump sum or unit price is named in the Contract Documents to cover such eliminated work, the price of the eliminated work shall be agreed upon in writing by the OWNER and the CONTRACTOR. If the OWNER and the CONTRACTOR fail to agree upon the price of the eliminated work, the price shall be determined in accordance with the provisions of Article 11.

ARTICLE 11 CHANGE OF CONTRACT PRICE

11.1 GENERAL

- A. The Contract Price constitutes the total compensation payable to the CONTRACTOR for performing the WORK. All duties, responsibilities, and obligations assigned to or undertaken by the CONTRACTOR to complete the WORK shall be at its expense without change in the Contract Price.
- B. The Contract Price may only be changed by a Change Order approved by the Borough Assembly. Any claim for an increase in the Contract Price shall be based on written notice delivered by the CONTRACTOR to the ENGINEER promptly (but in no event later than 7 days) after the start of the occurrence or the event giving rise to the claim and stating the general nature of the claim. Notice of the amount of the claim with all supporting documentation and data shall be delivered within 14 days after such occurrence (unless the ENGINEER allows an additional period of time to ascertain more accurate data in support of the claim) and shall be accompanied by the CONTRACTOR's written statement that the amount claimed covers all known amounts (direct, indirect, and consequential) to which the CONTRACTOR is entitled as a result of the occurrence or event. All claims for adjustment in the Contract Price shall be determined by the

SECTION 00700 - GENERAL CONDITIONS

ENGINEER in accordance with Paragraph 9.8A if the OWNER and the CONTRACTOR cannot otherwise agree on the amount involved. No claim for an adjustment in the Contract Price will be valid if not submitted in accordance with this Paragraph 11.1B.

- C. The value of any work covered by a Change Order or of any claim for an increase or decrease in the Contract Price shall be determined in one of the following ways:
1. Where the work involved is covered by unit prices contained in the Contract Documents, by application of unit prices to the quantities of the items involved. Unit prices not specified in the contract documents shall be determined by the unit price for that item or items in the CONTRACTOR'S bid.
 2. By mutual acceptance of a lump sum, which may, but is not required to, include an allowance for overhead and profit not necessarily in accordance with Paragraph 11.4.
 3. On the basis of the cost of work (determined as provided in Paragraphs 11.3) plus a CONTRACTOR's fee for overhead and profit (determined as provided in Paragraph 11.4).

11.2 COSTS RELATING TO WEATHER. The CONTRACTOR shall have no claims against the OWNER for damages for any injury to WORK, materials, or equipment, resulting from the action of the elements. If, however, in the opinion of the ENGINEER, the CONTRACTOR has made all reasonable efforts to protect the materials, equipment and work, the CONTRACTOR may be granted a reasonable extension of Contract Time to make proper repairs, renewals, and replacements of the work, materials, or equipment.

11.3 COST OF WORK (BASED ON TIME AND MATERIALS)

- A. General. The term "cost of work" means the sum of all costs actually and necessarily incurred and paid by the CONTRACTOR for labor, materials, and equipment in the proper performance of extra work. Except as otherwise may be agreed to in writing by the OWNER, such costs shall be in amounts no higher than those prevailing in the locality of the Project; shall include only the following items, and shall not include any of the costs itemized in Paragraph 11.5 EXCLUDED COSTS.
- B. Labor. The costs of labor will be the actual cost for wages prevailing for each craft or type of workers performing the extra work at the time the extra work is done, plus employer payments of payroll taxes, worker's compensation insurance, liability insurance, health and welfare, pension, vacation, apprenticeship funds, and other direct costs resulting from Federal, State or local laws, as well as assessments or benefits required by lawful collective bargaining agreements. Labor costs for equipment operators and helpers shall be paid only when such costs are not included in the invoice for equipment rental. The labor costs for forepersons shall be proportioned to all of their assigned work and only that applicable to extra work shall be paid. Non-direct labor costs including superintendence shall be considered part of the mark-up set out in paragraph 11.4.
- C. Materials. The cost of materials reported shall be at invoice or lowest current price at which materials are locally available and delivered to the job in the quantities involved, plus the cost of freight, delivery and storage, subject to the following:

SECTION 00700 - GENERAL CONDITIONS

1. Trade discounts available to the purchaser shall be credited to the OWNER notwithstanding the fact that such discounts may not have been taken by the CONTRACTOR.
 2. For materials secured by other than a direct purchase and direct billing to the purchaser, the cost shall be deemed to be the price paid to the actual supplier as determined by the ENGINEER. Mark-up except for actual costs incurred in the handling of such materials will not be allowed.
 3. Payment for materials from sources owned wholly or in part by the purchaser shall not exceed the price paid by the purchaser for similar materials from said sources on extra work items or the current wholesale price for such materials delivered to the work site, whichever price is lower.
 4. If in the opinion of the ENGINEER the cost of material is excessive, or the CONTRACTOR does not furnish satisfactory evidence of the cost of such material, then the cost shall be deemed to be the lowest current wholesale price for the quantity concerned delivered to the work site less trade discount. The OWNER reserves the right to furnish materials for the extra work and no claim shall be allowed by the CONTRACTOR for costs and profit on such materials.
- D. Equipment. The CONTRACTOR will be paid for the use of equipment at the rental rate listed for such equipment specified in the Supplementary General Conditions. Such rental rate will be used to compute payments for equipment whether the equipment is under the CONTRACTOR's control through direct ownership, leasing, renting, or another method of acquisition. The rental rate to be applied for use of each item of equipment shall be the rate resulting in the least total cost to the OWNER for the total period of use. If it is deemed necessary by the CONTRACTOR to use equipment not listed in the publication specified in the Supplementary General Conditions, an equitable rental rate for the equipment will be established by the ENGINEER. The CONTRACTOR may furnish cost data which might assist the ENGINEER in the establishment of the rental rate. The CONTRACTOR shall not be entitled for any rental rate for equipment the use of which would have necessary to provide the unit of work and which should have been included in the CONTRACTOR'S bid price for that unit of work.
1. All equipment shall, in the opinion of the ENGINEER, be in good working condition and suitable for the purpose for which the equipment is to be used.
 2. Before construction equipment is used on the extra work, the CONTRACTOR shall plainly stencil or stamp an identifying number thereon at a conspicuous location, and shall furnish to the ENGINEER, in duplicate, a description of the equipment and its identifying number.
 3. Unless otherwise specified, manufacturer's ratings and manufacturer approved modifications shall be used to classify equipment for the determination of applicable rental rates. Equipment which has no direct power unit shall be powered by a unit of at least the minimum rating recommended by the manufacturer.
 4. Individual pieces of equipment or tools having a replacement value of \$200 or less, whether or not consumed by use, shall be considered to be small tools and no payment will be made therefor.
 5. Rental time will not be allowed while equipment is inoperative due to breakdowns.
 6. Equipment Rental Rates. Unless otherwise agreed in writing, the CONTRACTOR will be paid for the use of equipment at the rental rate listed for such equipment specified in the current edition of the following reference publication: "Rental Rate Blue Book" as published by Dataquest (a company of the Dunn and Bradstreet

SECTION 00700 - GENERAL CONDITIONS

Corporation), 1290 Ridder Park Drive, San Jose, CA 95131, telephone number (800) 227-8444.

- E. Equipment on the Work Site. The rental time to be paid for equipment on the work site shall be the time the equipment is in productive operation on the extra work being performed and, in addition, shall include the time required to move the equipment to the location of the extra work and return it to the original location or to another location requiring no more time than that required to return it to its original location; except, that moving time will not be paid if the equipment is used on other than the extra work, even though located at the site of the extra work, or if it was not necessary to move equipment from another location to the site. Loading and transporting costs will be allowed, in lieu of moving time, when the equipment is moved by means other than its own power, except that no payment will be made for loading and transporting costs when the equipment is used at the site of the extra work on other than the extra work. The following shall be used in computing the rental time of equipment on the work site.
1. When hourly rates are listed, any part of an hour less than 30 minutes of operation shall be considered to be 1/2-hour of operation, and any part of an hour in excess of 30 minutes will be considered one hour of operation.
 2. When daily rates are listed, any part of a day less than 4 hours operation shall be considered to be 1/2-day of operation. When owner-operated equipment is used to perform extra work to be paid for on a time and materials basis, the CONTRACTOR will be paid for the equipment and operator, as set forth in Paragraphs (3), (4), and (5), following.
 3. Payment for the equipment will be made in accordance with the provisions in Paragraph 11.3D, herein.
 4. Payment for the cost of labor and subsistence or travel allowance will be made at the rates paid by the CONTRACTOR to other workers operating similar equipment already on the work site, or in the absence of such labor, established by collective bargaining agreements for the type of worker and location of the extra work, whether or not the operator is actually covered by such an agreement. A labor surcharge will be added to the cost of labor described herein in accordance with the provisions of Paragraph 11.3B, herein, which surcharge shall constitute full compensation for payments imposed by state and federal laws and all other payments made to or on behalf of workers other than actual wages.
 5. To the direct cost of equipment rental and labor, computed as provided herein, will be added the allowances for equipment rental and labor as provided in Paragraph 11.4, herein.
- F. Specialty Work. Specialty work is defined as that work characterized by extraordinary complexity, sophistication, or innovation or a combination of the foregoing attributes which are unique to the construction industry. The following shall apply in making estimates for payment for specialty work:
1. Any bid item of WORK to be classified as Specialty Work shall be listed as such in the Supplementary General Conditions. Specialty work shall be performed by an entity especially skilled in the work to be performed. After validation of invoices and determination of market values by the ENGINEER, invoices for specialty work based upon the current fair market value thereof may be accepted without complete itemization of labor, material, and equipment rental costs.

SECTION 00700 - GENERAL CONDITIONS

- 2. When the CONTRACTOR is required to perform work necessitating special fabrication or machining process in a fabrication or a machine shop facility away from the job site, the charges for that portion of the work performed at the off-site facility may, by agreement, be accepted as specialty work and accordingly, the invoices for the work may be accepted without detailed itemization.
- 3. All invoices for specialty work will be adjusted by deducting all trade discounts offered or available, whether the discounts were taken or not. In lieu of the allowances for overhead and profit specified in Paragraph 11.4, herein, an allowance of 5 percent will be added to invoices for specialty work.

G. Sureties. All work performed hereunder shall be subject to all of the provisions of the Contract Documents and the CONTRACTOR’s sureties shall be bound with reference thereto as under the original Agreement. Copies of all amendments to surety bonds or supplemental surety bonds shall be submitted to the OWNER for review prior to the performance of any work hereunder.

11.4 CONTRACTOR’S FEE

A. Extra work ordered on the basis of time and materials will be paid for at the actual necessary cost as determined by the ENGINEER, plus allowances for overhead and profit. The allowance for overhead and profit shall include full compensation for superintendence, bond and insurance premiums, taxes, field office expense, extended overhead, home office overhead, and all other items of expense or cost not included in the cost of labor, materials, or equipment provided for under Paragraph 11.3. The allowance for overhead and profit will be made in accordance with the following schedule:

Actual Overhead and Profit Allowance	
Labor	15 percent
Materials.....	10 percent
Equipment	10 percent

To the sum of the costs and mark-ups provided for in this Article, one percent shall be added as compensation for bonding.

B. It is understood that labor, materials, and equipment may be furnished by the CONTRACTOR or by the Subcontractor on behalf of the CONTRACTOR. When all or any part of the extra work is performed by a Subcontractor, the allowance specified herein shall be applied to the labor, materials, and equipment costs of the Subcontractor, to which the CONTRACTOR may add 5 percent of the Subcontractor’s total cost for the extra work. Regardless of the number of hierarchical tiers of Subcontractors, the 5 percent increase above the Subcontractor’s total cost which includes the allowances for overhead and profit specified herein may be applied one time only.

11.5 EXCLUDED COSTS. The term Cost of the Work shall not include any of the following:

A. Payroll costs and other compensation of CONTRACTOR’s officers, executives, principals (of partnership and sole proprietorships), general managers, engineers, estimators, attorneys’ auditors, accountants, purchasing and contracting agents, expenditures, timekeepers, clerks and other personnel employed by CONTRACTOR whether at the site or in CONTRACTOR’s principal or a branch office for general administration of the work, or not

SECTION 00700 - GENERAL CONDITIONS

specifically covered by paragraph 11.3, all of which are to be considered administrative costs covered by the CONTRACTOR's fee.

- B. Expenses of CONTRACTOR's principal and branch offices other than CONTRACTOR's office at the site.
- C. Any part of CONTRACTOR's capital expenses, including interest on CONTRACTOR's capital employed for the Work and charges against CONTRACTOR for delinquent payments.
- D. Cost of premiums for all bonds and for all insurance whether or not CONTRACTOR is required by the Contract Documents to purchase and maintain the same (except for the cost of premiums covered by paragraph 11.4 above).
- E. Costs due to the negligence of CONTRACTOR, any Subcontractor, or anyone directly or indirectly employed by any of them or for whose acts any of them may be liable, including but not limited to, the correction of Defective WORK, disposal of materials or equipment wrongly supplied and making good any damage to property.
- F. Other overhead or general expense costs of any kind and the cost of any item not specifically and expressly included in paragraph 11.4.
- G. Equipment rental cost for equipment that would be needed to perform the unit of work as reflected in the bid price for that unit of work.
- H. Mobilization or demobilization for equipment that would necessarily have been used to perform that unit of work as reflected in the bid price for that unit of work.

ARTICLE 12 CHANGE OF CONTRACT TIME

12.1 GENERAL

- A. The Contract Time may only be changed by a Change Order. Any claim for an extension of the Contract Time (or Milestones) shall be based on written notice delivered by the CONTRACTOR to the ENGINEER promptly (but in no event later than 30 days) after the occurrence of the event giving rise to the claim and stating the general nature of the claim. Notice of the extent of the claim with supporting data shall be delivered within 60 days after such occurrence (unless the ENGINEER allows an additional period of time to ascertain more accurate data in support of the claim) and shall be accompanied by the CONTRACTOR'S written statement that the adjustment claimed is the entire adjustment to which the CONTRACTOR has reason to believe it is entitled as a result of the occurrence of said event. All claims for adjustment in the Contract Time shall be determined by the ENGINEER in accordance with Paragraph 9.8 if the OWNER and the CONTRACTOR cannot otherwise agree. No claim for an adjustment in the Contract Time will be valid if not submitted in accordance with the requirements of this Paragraph 12.1A. An increase in Contract Time does not mean that the Contractor is due an increase in Contract Price. Only Compensable time extensions will result in an increase in Contract Price.
- B. All time limits stated in the Contract Documents are of the essence of the Agreement. OWNER reserves the right to direct CONTRACTOR to accelerate his work, at no cost to OWNER, if CONTRACTOR fails to maintain contract schedule.

SECTION 00700 - GENERAL CONDITIONS

- C. Where CONTRACTOR is prevented from completing any part of the Work within the Contract Times (or Milestones) due to delay beyond the control of CONTRACTOR, the Contract Times (or Milestones) will be extended in an amount equal to the time lost on the critical path of the project due to such delay if a claim is made therefor as provided in paragraph 12.1. Delays beyond the control of CONTRACTOR shall include, but not be limited to, acts or neglect of utility owners or other contractors performing other work as contemplated by Article 7, fires, floods, epidemics, unprecedented weather conditions or acts of God. Delays attributable to and within the control of a Subcontractor or Supplier shall be deemed to be delays within the control of CONTRACTOR.
- D. Where CONTRACTOR is prevented from completing any part of the WORK within the Contract Times (or Milestones) due to delay beyond the control of both OWNER and CONTRACTOR, an extension of the Contract Times (or Milestones) in an amount equal to the time lost on the critical path of the project due to such delay shall be CONTRACTOR's sole and exclusive remedy for such delay. In no event shall the OWNER be liable to CONTRACTOR, any Subcontractor, any Supplier, or any other person or organization, or to any surety for or employee or agent of any of them, for damages arising out of or resulting from (i) delays caused by or within the control of CONTRACTOR, or (ii) delays beyond the control of both parties including but not limited to fires, floods, epidemics abnormal weather conditions, acts of God or acts or neglect by utility owners or other contractors performing other work as contemplated by Article 7.

12.2 EXTENSIONS OF TIME FOR DELAY DUE TO WEATHER. Contract Time may be extended by the ENGINEER because of delays in completion of the WORK due to unusually severe weather, provided that the CONTRACTOR shall, within 10 days of the beginning of any such delay, notify the ENGINEER in writing of the cause of delay and request an extension of Contract Time. The ENGINEER will ascertain the facts and the extent of the delay and extend the time for completing the work when, in the ENGINEER's judgment, the findings of fact justify such an extension. Unprecedented, abnormal, or unusually severe weather will be defined as an event, or events, with a greater than 50-year recurrence interval, as determined by the National Weather Service, or equivalent State or Federal agency

ARTICLE 13 WARRANTY AND GUARANTEE; TESTS AND INSPECTIONS; CORRECTION, REMOVAL, OR ACCEPTANCE OF DEFECTIVE WORK

- 13.1 WARRANTY AND GUARANTEE. The CONTRACTOR warrants and guarantees to the OWNER and the ENGINEER that all work will be in accordance with the Contract Documents and will not be defective. Prompt notice of defects known to the OWNER or ENGINEER shall be given to the CONTRACTOR. All defective work, whether or not in place, may be rejected, corrected, or accepted as provided in this Article 13.
- 13.2 ACCESS TO WORK. OWNER, ENGINEER, their Consultants, sub-consultants, other representatives and personnel of OWNER, independent testing laboratories and governmental agencies with jurisdictional interests will have access to the Work at reasonable times for their observation, inspecting and testing. CONTRACTOR shall provide them proper and safe conditions for such access and advise them of CONTRACTOR's site safety procedures and programs so that they may comply therewith as applicable.

SECTION 00700 - GENERAL CONDITIONS

13.3 TESTS AND INSPECTIONS

- A. The CONTRACTOR shall give the ENGINEER timely notice of readiness of the WORK for all required inspections, tests, or approvals, and shall cooperate with inspection and testing personnel to facilitate required inspections or tests.
- B. If Laws or Regulations of any public body having jurisdiction other than the OWNER require any WORK to specifically be inspected, tested, or approved, the CONTRACTOR shall pay all costs in connection therewith. The CONTRACTOR shall also be responsible for and shall pay all costs in connection with any inspection or testing required in connection with the OWNER's or the ENGINEER's acceptance of a Supplier of materials or equipment proposed as a substitution or (or-equal) to be incorporated in the WORK, or of materials or equipment submitted for review prior to the CONTRACTOR's purchase thereof for incorporation in the WORK. The cost of all inspections, tests, and approvals in addition to the above which are required by the Contract Documents shall be paid by the OWNER (unless otherwise specified).
- C. The ENGINEER will make, or have made, such inspections and tests as the ENGINEER deems necessary to see that the WORK is being accomplished in accordance with the requirements of the Contract Documents. Unless otherwise specified in the Supplementary General Conditions, the cost of such inspection and testing will be borne by the OWNER. In the event such inspections or tests reveal non-compliance with the requirements of the Contract Documents, the CONTRACTOR shall bear the cost of corrective measures deemed necessary by the ENGINEER, as well as the cost of subsequent reinspection and retesting. Neither observations by the ENGINEER nor inspections, tests, or approvals by others shall relieve the CONTRACTOR from the CONTRACTOR's obligation to perform the WORK in accordance with the Contract Documents.
- D. All inspections, tests, or approvals other than those required by Laws or Regulations of any public body having jurisdiction shall be performed by organizations acceptable to the ENGINEER and the CONTRACTOR.
- E. If any work (including the work of others) that is to be inspected, tested, or approved is covered without written concurrence of the ENGINEER, it must, if requested by the ENGINEER, be uncovered for observation. Such uncovering shall be at the CONTRACTOR's expense unless the CONTRACTOR has given the ENGINEER timely notice of the CONTRACTOR's intention to perform such test or to cover the same and the ENGINEER has not acted with reasonable promptness in response to such notice.
- F. If any WORK is covered contrary to the written request of the ENGINEER, it must, if requested by the ENGINEER, be uncovered for the ENGINEER's observation and recovered at the CONTRACTOR's expense.
- G. If the ENGINEER considers it necessary or advisable that covered WORK be observed by the ENGINEER or inspected or tested by others, the CONTRACTOR, at the ENGINEER's request, shall uncover, expose, or otherwise make available for observation, inspection, or testing as the ENGINEER may require, that portion of the WORK in question, furnishing all necessary labor, material, and equipment. If it is found that such work is defective, the CONTRACTOR shall bear all direct, indirect, and consequential costs and damages of such uncovering, exposure, observation, inspection,

SECTION 00700 - GENERAL CONDITIONS

and testing and of satisfactory reconstruction, including but not limited to fees and charges of engineers, attorneys, and other professionals. However, if such work is not found to be defective, the CONTRACTOR shall be allowed an increase in the Contract Price or an extension of the Contract Time, or both, directly attributable to such uncovering, exposure, observation, inspection, testing, and reconstruction; and, if the parties are unable to agree as to the amount or extent thereof, the CONTRACTOR may make a claim therefor as provided in Articles 11 and 12.

13.4 OWNER MAY STOP THE WORK. If the WORK is defective, or the CONTRACTOR fails to perform work in such a way that the completed WORK will conform to the Contract Documents, the OWNER may order the CONTRACTOR to stop the WORK, or any portion thereof, until the cause for such order has been eliminated; however, this right of the OWNER to stop the WORK shall not give rise to any duty on the part of the OWNER to exercise this right for the benefit of the CONTRACTOR or any other party.

13.5 CORRECTION OR REMOVAL OF DEFECTIVE WORK. If required by the ENGINEER, the CONTRACTOR shall promptly, either correct all defective work, whether or not fabricated, installed, or completed, or, if the WORK has been rejected by the ENGINEER, remove it from the site and replace it with non-defective work. The CONTRACTOR shall bear all direct, indirect and consequential costs and damages of such correction or removal, including but not limited to fees and charges of engineers, attorneys, and other professionals made necessary thereby.

13.6 ONE YEAR CORRECTION PERIOD

A. If within one year after the date of Substantial Completion or such longer period of time as may be prescribed by Laws or Regulations or by the terms of any applicable special guarantee required by the Contract Documents or by any specific provision of the Contract Documents, any work is found to be defective, the CONTRACTOR shall promptly, without cost to the OWNER and in accordance with OWNER's written notification, (i) correct such Defective WORK, or, if it has been rejected by the OWNER, remove it from the site and replace it with non-defective work, and (ii) satisfactorily correct or remove and replace any damage to other work of others resulting therefrom. If the CONTRACTOR does not promptly comply with such notification, or in an emergency where delay would cause serious risk of loss or damage, the OWNER may have the Defective WORK corrected or the rejected WORK removed and replaced, and all direct, indirect, and consequential costs and damages of such removal and replacement including but not limited to fees and charges of engineers, attorneys and other professionals will be paid by the CONTRACTOR.

B. Where Defective WORK (and damage to other WORK resulting therefrom) has been corrected, removed or replaced under this paragraph 13.6, the correction period hereunder with respect to such WORK will be extended for an additional period of one year after such correction or removal and replacement has been satisfactorily completed.

13.7 ACCEPTANCE OF DEFECTIVE WORK. If, instead of requiring correction or removal and replacement of defective work, the OWNER prefers to accept the WORK, the OWNER may do so. The CONTRACTOR shall bear all direct, indirect, and consequential costs attributable to the OWNER's evaluation of and determination to accept such defective work. If any such acceptance occurs prior to final payment, a Change Order will be issued incorporating the necessary revisions in the Contract Documents with respect to the WORK, and the OWNER shall be entitled to an appropriate decrease in the Contract Price.

SECTION 00700 - GENERAL CONDITIONS

ARTICLE 14 PAYMENTS TO CONTRACTOR AND COMPLETION

- 14.1 SCHEDULE OF VALUES (LUMP SUM PRICE BREAKDOWN). The schedule of values or lump sum price breakdown established as provided in the General Requirements shall serve as the basis for progress payments and will be incorporated into a form of Application for Payment acceptable to the ENGINEER.
- 14.2 UNIT PRICE BID SCHEDULE. Progress payments on account of Unit Price work will be based on the number of units completed.
- 14.3 APPLICATION FOR PROGRESS PAYMENT
- A. Unless otherwise prescribed by law, on the 25th of each month, the CONTRACTOR shall submit to the ENGINEER for review, an Application for Payment filled out and signed by the CONTRACTOR covering the WORK completed as of the date of the Application and accompanied by such supporting documentation as is required by the Contract Documents.
- B. The Application for Payment shall identify, as a sub-total, the amount of the CONTRACTOR'S Total Earnings to Date, plus the Value of Materials Stored at the Site which have not yet been incorporated in the WORK, and less a deductive adjustment for materials installed which were not previously incorporated in the WORK, but for which payment was allowed under the provisions for payment for Materials Stored at the Site, but not yet incorporated in the WORK.
- C. Each Application for Payment shall be submitted with an updated Progress Schedule, as required in Section 01300 Contractor Submittals. Each Application for Payment will also be accompanied by Contractor and Subcontractor certified payroll reports for periods covered by the period covered by the Application for Payment.
- D. The Net Payment Due the CONTRACTOR shall be the above-mentioned subtotal from which shall be deducted the total amount of all previous payments made to the CONTRACTOR. Progress payments will be paid in full in accordance with Article 14 of the General Conditions until 90% of the Contract Price has been paid. The remaining 10% of the Contract Price amount may be withheld until:
1. final inspection has been made;
 2. completion of the project; and
 3. acceptance of the project by the OWNER.
- E. The Value of Materials Stored at the Site shall be an amount equal to the specified percent of the value of such materials as set forth in the Supplementary General Conditions. Said amount shall be based upon the value of all acceptable materials and equipment not incorporated in the WORK but delivered and suitably stored at the site or at another location agreed to in writing; provided, each such individual item has a value of more than \$5,000.00 and will become a permanent part of the WORK. The Application for Payment shall also be accompanied by an invoice (including shipping), a certification that the materials meet the applicable contract specifications, and any evidence required by the OWNER that the materials and equipment are covered by appropriate property insurance and other arrangements to protect the OWNER's interest

SECTION 00700 - GENERAL CONDITIONS

therein, all of which will be satisfactory to the OWNER. Payment for materials will not constitute final acceptance. It shall be the CONTRACTOR's responsibility to protect the material from damage, theft, loss, or peril while in storage. Unless otherwise prescribed by law, the Value of Materials Stored at the Site shall be paid at the invoice amount up to a maximum of 85% of the Contract Price for those items.

14.4 CONTRACTOR'S WARRANTY OF TITLE. The CONTRACTOR warrants and guarantees that title to all work, materials, and equipment covered by an Application for Payment, whether incorporated in the WORK or not, will pass to the OWNER no later than the time of payment free and clear of all liens.

14.5 REVIEW OF APPLICATIONS FOR PROGRESS PAYMENT

- A. The ENGINEER will, within 7 days after receipt of each Application for Payment, either indicate in writing a recommendation of payment and present the Application to the OWNER, or return the Application to the CONTRACTOR indicating in writing the ENGINEER's reasons for refusing to recommend payment. In the later case, the CONTRACTOR may make the necessary corrections and resubmit the Application, at which point the 7 days for ENGINEER review will begin again. If the ENGINEER still disagrees with a portion of the Application, it will submit the Application recommending the undisputed portion of the Application to the OWNER for payment and provide reasons for recommending non-payment of the disputed amount. Thirty days after presentation of the Application for Payment with the ENGINEER's recommendation, the amount recommended will (subject to the provisions of Paragraph 14.5B) become due and when due will be paid by the OWNER to the CONTRACTOR.
- B. The OWNER may refuse to make payment of the full amount recommended by the ENGINEER because claims have been made against the OWNER on account of the CONTRACTOR's performance of the WORK or Liens have been filed in connection with the WORK or there are other items entitling the OWNER to a credit against the amount recommended, but the OWNER must give the CONTRACTOR written notice within 7 days (with a copy to the ENGINEER) stating the reasons for such action.

14.6 PARTIAL UTILIZATION

- A. The OWNER shall have the right to utilize or place into service any item of equipment or other usable portion of the WORK prior to completion of the WORK. Whenever the OWNER plans to exercise said right, the CONTRACTOR will be notified in writing by the OWNER, identifying the specific portion or portions of the WORK to be so utilized or otherwise placed into service.
- B. It shall be understood by the CONTRACTOR that until such written notification is issued, all responsibility for care and maintenance of all of the WORK shall be borne by the CONTRACTOR. Upon issuance of said written notice of partial utilization, the OWNER will accept responsibility for the protection and maintenance of all such items or portions of the WORK described in the written notice.
- C. The CONTRACTOR shall retain full responsibility for satisfactory completion of the WORK, regardless of whether a portion thereof has been partially utilized by the OWNER and the CONTRACTOR's one year correction period shall commence only after the date of Substantial Completion for the WORK.

SECTION 00700 - GENERAL CONDITIONS

- 14.7 SUBSTANTIAL COMPLETION. When the CONTRACTOR considers the WORK ready for its intended use the CONTRACTOR shall notify the OWNER and the ENGINEER in writing that the WORK is substantially complete. The CONTRACTOR will attach to this request a list of all work items that remain to be completed and a request that the ENGINEER prepare a Notice of Completion. Within a reasonable time thereafter, the OWNER, the CONTRACTOR, and the ENGINEER shall make an inspection of the WORK to determine the status of completion. If the ENGINEER does not consider the WORK substantially complete, or the list of remaining work items to be comprehensive, the ENGINEER will notify the CONTRACTOR in writing giving the reasons therefor. If the ENGINEER considers the WORK substantially complete, the ENGINEER will prepare and deliver to the OWNER, for its execution and recording, the Notice of Completion signed by the ENGINEER and CONTRACTOR, which shall fix the date of Substantial Completion.
- 14.8 FINAL APPLICATION FOR PAYMENT. After the CONTRACTOR has completed all of the remaining work items referred to in Paragraph 14.7 and delivered all maintenance and operating instructions, schedules, guarantees, Bonds, certificates of inspection, contract releases, record as-built documents (as provided in the General Requirements) and other documents, all as required by the Contract Documents, and after the ENGINEER has indicated that the WORK is acceptable, the CONTRACTOR may make application for final payment following the procedure for progress payments. The final Application for Payment shall be accompanied by all documentation called for in the Contract Documents, together with complete and legally effective releases or waivers (satisfactory to the OWNER) of all liens arising out of or filed in connection with the WORK.
- 14.9 FINAL PAYMENT AND ACCEPTANCE
- A. If, on the basis of the ENGINEER's observation of the WORK during construction and final inspection, and the ENGINEER's review of the final Application for Payment and accompanying documentation, all as required by the Contract Documents, the ENGINEER is satisfied that the WORK has been completed and the CONTRACTOR's other obligations under the Contract Documents have been fulfilled, the ENGINEER will, within 14 days after receipt of the final Application for Payment, indicate in writing the ENGINEER's recommendation of payment and present the Application to the OWNER for payment.
- B. After acceptance of the WORK by the OWNER's governing body, the OWNER will make final payment to the CONTRACTOR of the amount remaining after deducting all prior payments and all amounts to be kept or retained under the provisions of the Contract Documents, including the following items:
1. Liquidated damages, as applicable.
 2. Two times the value of outstanding items of correction work or punch list items yet uncompleted or uncorrected, as applicable. All such work shall be completed or corrected to the satisfaction of the OWNER within the time stated on the Notice of Completion, otherwise the CONTRACTOR does hereby waive any and all claims to all monies withheld by the OWNER to cover the value of all such uncompleted or uncorrected items.
- 14.10 RELEASE OF RETAINAGE AND OTHER DEDUCTIONS

SECTION 00700 - GENERAL CONDITIONS

- A. After executing the necessary documents to initiate the lien period, and not more than 45 days thereafter (based on a 30-day lien filing period and 15-day processing time), the OWNER will release to the CONTRACTOR the retainage funds withheld pursuant to the Agreement, less any deductions to cover pending claims against the OWNER pursuant to Paragraph 14.5B.
- B. After filing of the necessary documents to initiate the lien period, the CONTRACTOR shall have 30 days to complete any outstanding items of correction work remaining to be completed or corrected as listed on a final punch list made a part of the Notice of Completion. Upon expiration of the 45 days, referred to in Paragraph 14.10A, the amounts withheld pursuant to the provisions of Paragraph 14.9B herein, for all remaining work items will be returned to the CONTRACTOR; provided, that said work has been completed or corrected to the satisfaction of the OWNER within said 30 days. Otherwise, the CONTRACTOR does hereby waive any and all claims for all monies withheld by the OWNER under the Contract to cover 2 times the value of such remaining uncompleted or uncorrected items.
- 14.11 **CONTRACTOR'S CONTINUING OBLIGATION.** The CONTRACTOR's obligation to perform and complete the WORK in accordance with the Contract Documents shall be absolute. Neither recommendation of any progress or final payment by the ENGINEER, nor the issuance of a Notice of Completion, nor any payment by the OWNER to the CONTRACTOR under the Contract Documents, nor any use or occupancy of the WORK or any part thereof by the OWNER, nor any act of acceptance by the OWNER nor any failure to do so, nor any review of a Shop Drawing or sample submittal, will constitute an acceptance of work not in accordance with the Contract Documents or a release of the CONTRACTOR's obligation to perform the WORK in accordance with the Contract Documents.
- 14.12 **FINAL PAYMENT TERMINATES LIABILITY OF OWNER.** Final payment is defined as the last progress payment made to the CONTRACTOR for earned funds, less monies withheld as applicable, pursuant to Paragraph 14.10A. The acceptance by the CONTRACTOR of the final payment referred to in Paragraph 14.9 herein, shall be a release of the OWNER and its agents from all claims of liability to the CONTRACTOR for anything done or furnished for, or relating to, the WORK or for any act of neglect of the OWNER or of any person relating to or affecting the WORK, except demands against the OWNER for the remainder, if any, of the amounts kept or retained under the provisions of Paragraph 14.9 herein; and excepting pending, unresolved claims filed prior to the date of the Notice of Completion.

ARTICLE 15 SUSPENSION OF WORK AND TERMINATION

- 15.1 **SUSPENSION OF WORK BY OWNER.** The OWNER, acting through the ENGINEER, may, at any time and without cause, suspend the WORK or any portion thereof for a period of not more than 90 days by notice in writing to the CONTRACTOR. The CONTRACTOR shall resume the WORK on receipt from the ENGINEER of a notice of resumption of work. The CONTRACTOR shall be allowed an increase in the Contract Price or an extension of the Contract Time, or both, directly attributable to any suspension if the CONTRACTOR makes an approved claim therefor as provided in Articles 11 and 12.
- 15.2 **TERMINATION OF AGREEMENT BY OWNER (CONTRACTOR DEFAULT)**
- A. In the event of default by the CONTRACTOR, the OWNER may give 10 days written notice to the CONTRACTOR of OWNER's intent to terminate the Agreement and

SECTION 00700 - GENERAL CONDITIONS

provide the CONTRACTOR an opportunity to remedy the conditions constituting the default. It shall be considered a default by the CONTRACTOR whenever CONTRACTOR shall: (1) declare bankruptcy, become insolvent, or assign its assets for the benefit of its creditors; (2) fail to provide materials or quality of work meeting the requirements of the Contract Documents; (3) disregard or violate provisions of the Contract Documents or ENGINEER's instructions; (4) fail to prosecute the WORK according to the approved progress schedule; or, (5) fail to provide a qualified superintendent, competent workers, or materials or equipment meeting the requirements of the Contract Documents; or 5) breach any of the material terms of the Agreement or the Contract documents. If the CONTRACTOR fails to remedy the conditions constituting default within the time allowed, the OWNER may then issue the Notice of Termination.

- B. In the event the Agreement is terminated in accordance with Paragraph 15.2A, herein, the OWNER may take possession of the WORK and may complete the WORK by whatever method or means the OWNER may select. The cost of completing the WORK shall be deducted from the balance which would have been due the CONTRACTOR had the Agreement not been terminated and the WORK completed in accordance with the Contract Documents. If such cost exceeds the balance which would have been due, the CONTRACTOR shall pay the excess amount to the OWNER. If such cost is less than the balance which would have been due, the CONTRACTOR shall not have claim to the difference.

15.3 TERMINATION OF AGREEMENT BY OWNER (FOR CONVENIENCE). The OWNER may terminate the Agreement at any time in its sole discretion in the best interests of the City and Borough of Wrangell. In such a case, the CONTRACTOR shall have no claims against the OWNER except: (1) for the value of work performed up to the date the Agreement is terminated, which shall be based on the CONTRACTOR'S bid price for all units of work performed and in no circumstances shall exceed the bid price for each unit of work actually performed; and, (2) for the cost of materials and equipment on hand, in transit, or on definite commitment, as of the date the Agreement is terminated which would be needed in the WORK and which meet the requirements of the Contract Documents. The value of work performed and the cost of materials and equipment delivered to the site, as mentioned above, shall be determined by the ENGINEER in accordance with the procedure prescribed for the making of the final application for payment and payment under Paragraphs 14.8 and 14.9.

15.4 TERMINATION OF AGREEMENT BY CONTRACTOR. The CONTRACTOR may terminate the Agreement upon 10 days written notice to the OWNER, whenever: 1) the WORK has been suspended under the provisions of Paragraph 15.1, herein, for more than 90 consecutive days through no fault or negligence of the CONTRACTOR, and notice to resume work or to terminate the Agreement has not been received from the OWNER within this time period; or, 2) the OWNER should fail to pay the CONTRACTOR any monies due him as approved for payment by the ENGINEER in accordance with the terms of the Contract Documents and within 60 days after presentation to the OWNER by the CONTRACTOR of a request therefor, unless within the 10-day period the OWNER shall have remedied the condition upon which the payment delay was based. In the event of such termination, the CONTRACTOR shall have no claims against the OWNER except for those claims specifically enumerated in Paragraph 15.3, herein, and as determined in accordance with the requirements of that paragraph.

ARTICLE 16 MISCELLANEOUS

SECTION 00700 - GENERAL CONDITIONS

- 16.1 GIVING NOTICE. Whenever any provision of the Contract Documents requires the giving of written notice, it will be deemed to have been validly given if delivered in person to the individual or to a member of the firm or to an officer of the corporation for whom it is intended, or if delivered at or sent by registered or certified mail, postage prepaid, to the last business address known to the giver of the notice. E-mail shall not constitute written notice.
- 16.2 RIGHTS IN AND USE OF MATERIALS FOUND ON THE WORK
- A. The CONTRACTOR may use on the Project, with ENGINEER's approval, such stone, gravel, sand, or other material determined suitable by the ENGINEER, as may be found in the excavation. The CONTRACTOR will be paid for the excavation of such material at the corresponding contract unit price. No additional payment will be made for utilizing the material from excavation as borrow or select borrow.
 - B. The CONTRACTOR shall replace, at its own expense, with other acceptable material, all of that portion of the excavated material so removed and used which was needed for use on the project. No charge for the materials so used will be made against the CONTRACTOR except that the CONTRACTOR shall be responsible for payment of any royalties required.
 - C. The CONTRACTOR shall not excavate or remove any material from within the Project location which is not within the grading limits, as indicated by the slope and grade lines, without written authorization from the ENGINEER.
 - D. In the event the CONTRACTOR has processed materials from OWNER-furnished sources in excess of the quantities required for performance of this contract, including any waste material produced as a by-product, the OWNER may retain possession of such materials without obligation to reimburse the CONTRACTOR for the cost of their production. When such materials are in a stockpile, the ENGINEER may require: That it remain in stockpile; the CONTRACTOR level such stockpile(s); or that the CONTRACTOR remove such materials and restore the premises to a satisfactory condition at the CONTRACTOR's expense. This provision shall not preclude the OWNER from arranging with the CONTRACTOR to produce material over and above the contract needs, payment for which shall be by written agreement between the OWNER and the CONTRACTOR.
 - E. Unless otherwise provided, the material from any existing old structure may be used temporarily by the CONTRACTOR in the erection of the new structure. Such material shall not be cut or otherwise damaged except with the approval of the ENGINEER.
- 16.3 RIGHT TO AUDIT. If the CONTRACTOR submits a claim to the OWNER for additional compensation, the OWNER shall have the right, as a condition to considering the claim, and as a basis for evaluation of the claim, and until the claim has been settled, to audit the CONTRACTOR's books to the extent they are relevant. This right shall include the right to examine books, records, documents, and other evidence and accounting procedures and practices, sufficient to discover and verify all direct and indirect costs of whatever nature claimed to have been incurred or anticipated to be incurred and for which the claim has been submitted. The right to audit shall include the right to inspect the CONTRACTOR's plants, or such parts thereof, as may be or have been engaged in the performance of the WORK. The CONTRACTOR further agrees that the right to audit encompasses all subcontracts and is binding upon Subcontractors. The rights to examine and inspect herein provided for shall be exercisable through such

SECTION 00700 - GENERAL CONDITIONS

representatives as the OWNER deems desirable during the CONTRACTOR's normal business hours at the office of the CONTRACTOR. The CONTRACTOR shall make available to the OWNER for auditing, all relevant accounting records and documents, and other financial data, and upon request, shall submit true copies of requested records to the OWNER.

- 16.4 **ARCHAEOLOGICAL OR HISTORICAL DISCOVERIES.** When the CONTRACTOR's operation encounters prehistoric artifacts, burials, remains of dwelling sites, paleontological remains, such as shell heaps, land or sea mammal bones or tusks, or other items of historical significance, the CONTRACTOR shall cease operations immediately and notify the ENGINEER. No artifacts or specimens shall be further disturbed or removed from the ground and no further operations shall be performed at the site until so directed. Should the ENGINEER order suspension of the CONTRACTOR's operations in order to protect an archaeological or historical finding, or order the CONTRACTOR to perform extra work, such order(s) shall be covered by an appropriate contract change document.
- 16.5 **CONSTRUCTION OVER OR ADJACENT TO NAVIGABLE WATERS.** All work over, on, or adjacent to navigable waters shall be so conducted that free navigation of the waterways will not be interfered with and the existing navigable depths will not be impaired, except as allowed by permit issued the U.S. Coast Guard and/or the U.S. Army Corps of Engineers, as applicable.
- 16.6 **GRATUITY AND CONFLICT OF INTEREST.** The CONTRACTOR agrees to not extend any loan, gratuity, or gift of money of any form whatsoever to any employee or elected official of the OWNER.

16.7 SUITS OF LAW CONCERNING THE WORK

A. The Superior Court for the State of Alaska, First Judicial District at Wrangell, Alaska, shall be the exclusive jurisdiction and venue for any action of any kind an any nature arising out of or relating to this Agreement and all Contract documents or for any action of any kind and any nature arising out of or related to the performance of non-performance of the CONTRATOR, and CONTRACTOR'S employees, subcontractors, consultants and representatives.

- B. If one of the questions at issue is the satisfactory performance of the work by the CONTRACTOR and should the appropriate court of law judge the work of the CONTRACTOR to be unsatisfactory, then the CONTRACTOR (or the CONTRACTOR's surety) shall reimburse the OWNER for all legal and all other expenses (as may be allowed and set by the court) incurred by the OWNER because of the suit of the law and, further, it is agreed that the OWNER may deduct such expense from any sum or sums then, or any that become due the CONTRACTOR under the contract.

16.8 CERTIFIED PAYROLLS

- A. All CONTRACTORS and Subcontractors shall conform to State of Alaska's Title 36 Public Contract Requirements as published in the Wage and Hour Administration Pamphlet 400 latest edition.
- B. All CONTRACTORs and Subcontractors who perform work on a public construction contract for the OWNER shall file a certified payroll with Alaska Department of Labor.

SECTION 00700 - GENERAL CONDITIONS

See Section 00830 - Alaska Labor Standards, Reporting, and Prevailing Wage Rate Determination.

- B. In lieu of submitting the State payroll form, the CONTRACTOR's standard payroll form may be submitted, provided it contains the information required by AS 36.05.040 and a statement that the CONTRACTOR is complying with AS 36.10.010.
- C. A CONTRACTOR or Subcontractor, who performs work on public construction in the State, as defined by AS 36.95.010(3), shall pay not less than the current prevailing rate of wages as issued by the Alaska Department of Labor before the end of the pay period. (AS 36.05.010).

16.9 PREVAILING WAGE RATES

- A. Wage rates for Laborers and Mechanics on Public Contracts, AS 36.05.070. The CONTRACTOR, or Subcontractors, shall pay all employees unconditionally and not less than once a week. Wages may not be less than those stated in Paragraph 16.8C, regardless of the contractual relationship between the CONTRACTOR or Subcontractors and laborers, mechanics, or field surveyors. The scale of wages to be paid shall be posted by the CONTRACTOR in a prominent, easily accessible place at the site of the WORK.
- B. Failure to Pay Agreed Wages, AS 36.05.080. If it is found that a laborer, mechanic, or field surveyor employed by the CONTRACTOR or Subcontractor has been, or is being, paid a rate or wages less than the established rate, the OWNER may, by written notice, terminate the CONTRACTOR or Subcontractors right to proceed with the work. The OWNER may prosecute the work to completion by contract or otherwise, and the CONTRACTOR and sureties will be held liable to the OWNER for excess costs for completing the WORK. (Section 2 ch 52 SLA 1959).
- F. Listing CONTRACTOR's Who Violate Contracts, AS 36.05.090. In addition, a list giving the names of persons who have disregarded the rights of their employees shall be distributed to all departments of State government and all political subdivisions. No person appearing on this list, and no firm, corporation, partnership or association in which the person has an interest, may work as a CONTRACTOR or Subcontractor on a public construction contract for the State, or a political subdivision of the state, until three years after the date of publication of the list. (Section 3 ch 52 SLA 1959; am Section 9 ch 142 SLA).

16.10 EMPLOYMENT REFERENCE. Workers employed in the execution of the contract by the CONTRACTOR or by any Subcontractor under this contract shall not be required or permitted to labor more than 8 hours a day or 40 hours per week in violation of the provisions of the Alaska Wage and Hour Act, Section 23.10.060.

16.11 COST REDUCTION INCENTIVE

- A. At any time within 45 days after the date of the Notice of Award, the CONTRACTOR may submit to the ENGINEER in writing, proposals for modifying the plans, specifications, or other requirements of this contract for the sole purpose of reducing the total cost of construction. The cost reduction proposal shall not impair in any manner the essential functions or characteristics of the project, including but not limited to, service

SECTION 00700 - GENERAL CONDITIONS

life, economy of operation, ease of maintenance, desired appearance or design and safety standards.

- B. The cost reduction proposal shall contain the following information:
1. Description of both the existing contract requirements for performing the WORK and the proposed changes.
 2. An itemization of the contract requirements that must be changed if the proposal is adopted.
 3. A detailed estimate of the time required and the cost of performing the WORK under both the existing contract and the proposed change.
 4. A statement of the date by which the CONTRACTOR must receive the decision from the OWNER on the cost reduction proposal.
 5. The contract items of WORK affected by the proposed changes including any quantity variations.
 6. A description and estimate of costs the OWNER may incur in implementing the proposed changes, such as test and evaluation and operating and support costs.
 7. A prediction of any effects the proposed change would have on future operations and maintenance costs to the OWNER.
- C. The provisions of this section shall not be construed to require the OWNER to consider any cost reduction proposal which may be submitted; nor will the OWNER be liable to the CONTRACTOR for failure to accept or act upon any cost reduction proposal submitted, or for delays to the work attributable to the consideration or implementation of any such proposal.
- D. If a cost reduction proposal is similar to a change in the plans or specifications for the project under consideration by the OWNER at the time the proposal is submitted, the OWNER will not accept such proposal and reserves the right to make such changes without compensation to the CONTRACTOR under the provisions of this section.
- E. The CONTRACTOR shall continue to perform the work in accordance with the requirements of the contract until an executed Change Order incorporating the cost reduction proposal has been issued. If any executed Change Order has not been issued by the date upon which the CONTRACTOR's cost reduction proposal specifies that a decision should be made by the OWNER, in writing, the cost reduction proposal shall be considered rejected.
- F. The OWNER shall be the sole judge of the acceptability of a cost reduction proposal and of the estimated net savings in Contract Time and construction costs resulting from the adoption of all or any part of such proposal. Should the CONTRACTOR disagree with OWNER's decision on the cost reduction proposal, there is no further consideration. The OWNER reserves the right to make final determination.
- G. If the CONTRACTOR's cost reduction proposal is accepted in whole or in part, such acceptance will be made by a contract Change Order, which specifically states that the change is executed pursuant to this cost reduction proposal section. Such Change Order shall incorporate the changes in the plans and specifications which are necessary to permit the cost reduction proposal or such part of it as has been accepted to be put into effect and shall include any conditions upon which the OWNER's approval is based, if such approval is conditional. The Change Order shall also describe the estimated net

SECTION 00700 - GENERAL CONDITIONS

savings in the cost of performing the work attributable to the cost reduction proposal, and shall further provide that the contract cost be adjusted by crediting the OWNER with the estimated net savings amount.

- H. Acceptance of the cost reduction proposal and performance of the work does not extend the time of completion of the contract, unless specifically provided in the Change Order authorizing the use of the submitted proposal. Should the adoption of the cost reduction proposal result in a Contract Time savings, the total Contract Time shall be reduced by an amount equal to the time savings realized.
- I. The amount specified to the CONTRACTOR in the Change Order accepted in the cost reduction proposal shall constitute full compensation for the performance of WORK. No claims for additional costs as a result of the changes specified in the cost reduction proposal shall be allowed.
- J. The OWNER reserves the right to adopt and utilize any approved cost reduction proposal for general use on any contract administered when it is determined suitable for such application. Cost reduction proposals identical, similar, or previously submitted will not be accepted for consideration if acceptance and compensation has previously been approved. The OWNER reserves the right to use all or part of any cost reduction proposal without obligation or compensation of any kind to the CONTRACTOR.
- K. The CONTRACTOR shall bear the costs, if any, to revise all bonds and insurance requirements for the project, to include the cost reduction WORK.

END OF SECTION

SECTION 00800 - SUPPLEMENTARY GENERAL CONDITIONS

GENERAL. These Supplementary General Conditions make additions, deletions, or revisions to the General Conditions as indicated herein. All provisions which are not so added, deleted, or revised remain in full force and effect. Terms used in these Supplementary General Conditions which are defined in the General Conditions have the meanings assigned to them in the General Conditions.

SGC 4.2 PHYSICAL CONDITIONS - SUBSURFACE AND EXISTING STRUCTURES. *Add* the following:

In the preparation of the Contract Documents, the OWNER has relied upon:

1. Field measurements and visual inspection of the existing structures and surface conditions.

SGC 5.2 INSURANCE AMOUNTS. The limits of liability for the insurance required by Paragraph 5.2 of the General Conditions shall provide coverage for not less than the following amounts or greater where required by Laws and Regulations:

A. Workers' Compensation: (under Paragraph 5.2, C. 1 of the General Conditions) as in accordance with AS 23.30.045:

1. State: Statutory
2. Applicable Federal (e.g., Longshore): Statutory

Note: If the WORK called for in the Contract Documents involves work in or on any navigable waters, the CONTRACTOR shall provide Workers' Compensation coverage which shall include coverage under the Longshore and Harbor Workers' Compensation Act, the Jones Act, and any other coverage required under Federal or State laws pertaining to workers in or on navigable waters.

3. Employers Liability

Bodily Injury by Accident:	\$100,000.00	Each Accident
Bodily Injury by Disease:	\$100,000.00	Each Employee
Bodily Injury by Disease:	\$500,000.00	Policy Limit

- a. CONTRACTOR agrees to waive all rights of subrogation against the OWNER and ENGINEER for work performed under Contract.
- b. If CONTRACTOR directly utilizes labor outside of the State of Alaska in the prosecution of the WORK, "Other States" endorsement shall be required as a condition of the Contract.

B. Commercial General Liability: (under Paragraph 5.2, C. 2 of the General Conditions):

1. Combined Single Limit

a. General Policy	\$2,000,000.00	Each Occurrence
	\$3,000,000.00	Annual Aggregate
b. Products/Completed Operations	\$2,000,000.00	Each Occurrence
	\$3,000,000.00	Annual Aggregate

SECTION 00800 - SUPPLEMENTARY GENERAL CONDITIONS

c. Personal Injury \$2,000,000.00 Each Occurrence

C. Commercial Automobile Liability: (under Paragraph 5.2, C. 3 of the General Conditions) including Owned, Hired, and Non-Owned Vehicles:

Combined Single Limit, Bodily Injury and Property Damage \$1,000,000.00

D. Policies shall also specify insurance provided by CONTRACTOR will be considered primary and not contributory to any other insurance available to the OWNER or the ENGINEER.

E. All policies will provide for thirty (30) days written notice prior to any cancellation or nonrenewal of insurance policies required under Contract except in the event of no-payment of premium where 10 Days is permissible.

F. The OWNER shall be named as an "Additional Insured" under all liability coverages listed in this Section, except for workers' compensation insurance. CONTRACTOR shall furnish OWNER a certificate from the insurer showing the OWNER as an Additional Insured within ten (10) days of the CONTRACTOR receiving the Notice to Proceed. Failure of the CONTRACTOR to fully and strictly comply with this Section shall constitute a default and a material breach of the Agreement and Contract documents.

SGC 14.9 FINAL PAYMENT AND ACCEPTANCE. Add the following paragraph:

C. Prior to the final payment the CONTRACTOR shall contact the Alaska Department of Labor (ADOL) and provide the OWNER with clearance from the ADOL for the CONTRACTOR and all Subcontractors that have worked on the Project. This clearance shall indicate that all Employment Security Taxes have been paid. A sample letter for this purpose is provided at the end of this section.

SAMPLE LETTER to Alaska Department of Labor for Employment Security Taxes

Date: _____

To: Alaska Department of Labor
Juneau Field Tax Office
FAX 907-465-2374

From: _____

Subject: REID STREET SIDEWALK REPLACEMENT

Timeframe of Contract _____

Please advise whether or not clearance is granted for the following CONTRACTOR or Subcontractor:

Name Address

Per AS 23.20.265 of the Alaska Employment Security Act, this request is for tax liability clearance and release to make final payment for WORK performed under the subject contract. Please send your

SECTION 00800 - SUPPLEMENTARY GENERAL CONDITIONS

response to:

Jeff Good, Borough Manager
City & Borough of Wrangell
PO Box 531
Wrangell, Alaska 99929
Telephone: (907) 874-2381
Fax: (907) 874-3952

- Tax Clearance is granted.
- Tax Clearance is NOT granted.

Remarks: _____

Signature

Date

Title

END OF SECTION

SECTION 01010 - SUMMARY OF WORK

PART 1 – GENERAL

1.1 GENERAL

- A. The WORK to be performed under this contract shall consist of furnishing all plant, tools, equipment, materials, supplies, manufactured articles, labor, transportation and services, including fuel, power, water, and essential communications, and performing all WORK, or other operations required for the fulfillment of the contract in strict accordance with the Contract Documents. The WORK shall be complete, and all work, materials, and services not expressly indicated or called for in the Contract Documents which may be necessary for the complete and proper construction of the WORK in good faith shall be provided by the CONTRACTOR as though originally so indicated, at no increase in cost to the OWNER.

1.2 WORK COVERED BY CONTRACT DOCUMENTS

WORK consists of all activities and equipment necessary for replacing to a portion of the Reid Street sidewalk, as shown in the contract documents, including asphalt cutting, concrete and guardrail demolition and disposal, excavation, base course, and concrete placement.

- A. Contractor's duties:

1. Except as specifically noted, provide, and pay for:

- a. All materials required for the work.
- b. Labor, tools and equipment.
- c. Tools, construction equipment and machinery.
- d. Water, heat and other utilities required for construction.
- e. Other facilities and services necessary for proper execution and completion of work

1.3 SITE OF THE WORK

- A. The site of Reid Street, behind the Community Center, in Wrangell, Alaska.

1.4 BEGINNING AND COMPLETION OF THE WORK

- A. Time is the essence of the contract. All WORK shall be completed in accordance with the following schedule. The OWNER will open the work site to the CONTRACTOR immediately following the Notice to Proceed. Substantial Completion must be reached by August 19, 2022. Final Completion, including handrail installation must be reached no later than September 30, 2022.

1.5 CONTRACT METHOD

- A. The WORK hereunder will be constructed under a unit price contract.

1.6 WORK BY OTHERS

SECTION 01010 - SUMMARY OF WORK

- A. The CONTRACTOR's attention is directed to the fact that work may be conducted at the site by other contractors during the performance of the WORK under this Contract. The CONTRACTOR shall conduct its operations so as to cause a minimum of interference with the work of such other contractors, and shall cooperate fully with such contractors to provide continued safe access to their respective portions of the site, as required to perform work under their respective contracts.
- B. Interference With Work on Utilities: The CONTRACTOR shall cooperate fully with all utility forces of the OWNER or forces of other public or private agencies engaged in the relocation, altering, or otherwise rearranging of any facilities which interfere with the progress of the WORK, and shall schedule the WORK to minimize interference with said relocation, altering, or other rearranging of facilities.

1.7 CONTRACTOR USE OF PROJECT SITE

- A. The CONTRACTOR's use of the Project site shall be limited to its construction operations in a single area at any given period, including on-site storage of materials. The CONTRACTOR shall coordinate with the OWNER for final staging area limits.
- B. The work shall be considered substantially complete when OWNER can occupy the Project Area for its intended and unobstructed use, a pedestrian walkway.

1.8 OWNER USE OF THE PROJECT SITE

- A. The OWNER may utilize all or part of the existing site during the entire period of construction for the conduct of the OWNER's normal operations. The CONTRACTOR shall cooperate and coordinate with the OWNER to facilitate the OWNER's operations and to minimize interference with the CONTRACTOR's operations at the same time. In any event, the OWNER shall be allowed access to the Project site during the period of construction.

1.9 PROJECT MEETINGS

- A. Pre-Construction Conference
 - 1. Prior to the commencement of WORK at the site, a Pre-Construction Conference will be held at a mutually agreed time and place which shall be attended by the CONTRACTOR's Project manager, its superintendent, and its Subcontractors as the CONTRACTOR deems appropriate. Other attendants will be:
 - a. Representatives of OWNER.
 - b. Governmental representatives as appropriate.
 - c. Others as requested by CONTRACTOR, OWNER, or ENGINEER.
 - 2. Unless previously submitted to the OWNER, the CONTRACTOR shall bring one copy each of the following:
 - a. Plan of Operation.
 - b. Project Overview Bar Chart Schedule.
 - c. Name and telephone number of CONTRACTOR's Project Supervisor.

SECTION 01010 - SUMMARY OF WORK

- d. Schedule of Values
- 3. The purpose of the Pre-Construction Conference is to designate responsible personnel and establish a working relationship. Matters requiring coordination will be discussed and procedures for handling such matters established. The complete agenda will be furnished to the CONTRACTOR prior to the meeting date.

The CONTRACTOR should be prepared to discuss all the items listed below:

- a. Status of CONTRACTOR's insurance and bonds.
 - b. CONTRACTOR's tentative schedules.
 - c. Transmittal, review, and distribution of CONTRACTOR's submittals.
 - d. Processing applications for payment.
 - e. Maintaining record documents.
 - f. Critical WORK sequencing.
 - g. Field decisions and Change Orders.
 - h. Use of Project site, office and storage areas, security, housekeeping, and OWNER's needs.
 - i. Traffic control and access
 - j. Major equipment deliveries and priorities.
 - k. CONTRACTOR's assignments for safety and first aid.
- 4. The OWNER will preside at the Pre-Construction Conference and will arrange for keeping and distributing the minutes to all persons in attendance.
 - 5. The CONTRACTOR and its Subcontractors should plan on the conference taking no less than 2 hours. The items listed in paragraph 3 will be covered as well as reviewing the plans and specifications, in extensive detail, with the OWNER.

B. Progress Meetings

- 1. The CONTRACTOR shall schedule and hold weekly progress meetings and at other times as requested by the OWNER, or as required by progress of the WORK. The CONTRACTOR and all subcontractors active on the site must attend each meeting. CONTRACTOR may at its discretion request attendance by representatives of its suppliers, manufacturers, and other subcontractors.
- 2. The OWNER shall preside at the meetings and will arrange for keeping and distributing the minutes. The purpose of the meetings will be to review the progress of the WORK, maintain coordination of efforts, discuss changes in scheduling, and resolve other problems which may develop. During each meeting, the CONTRACTOR is required to present any issues which may impact its work, with a view to resolve these issues expeditiously.

PART 2 - PRODUCTS (Not Used)

PART 3 - EXECUTION (Not Used)

END OF SECTION

SECTION 01025 - MEASUREMENT AND PAYMENT

PART 1 - GENERAL

1.1 SCOPE

- A. Payment for the various items of the Bid Schedule, as further specified herein, shall include all compensation to be received by the CONTRACTOR for furnishing all tools, equipment, supplies, and manufactured articles, and for all labor, operations, and incidentals appurtenant to the items of WORK being described, as necessary to complete the various items of the WORK all in accordance with the requirements of the Contract Documents, including all appurtenances thereto, and including all costs of PERMITS and cost of compliance with the regulations of public agencies having jurisdiction, including Safety and Health Requirements of the Occupational Safety and Health Administration of the U.S. Department of Labor (OSHA).
- B. No separate payment will be made for any pay item that is not specifically set forth in the Bid Schedule, and all costs therefore shall be included in the prices named in the Bid Schedule for the various appurtenant items of WORK.
- C. In addition to other incidental items of WORK listed elsewhere in the contract, the following items shall also be considered as incidental to other items of WORK under this contract:
 - 1. Temporary access between work areas to maintain dock operations.
 - 2. Bracing of existing facilities as required for construction any/all improvements.
 - 3. Temporary support of existing concrete curbing and slabs.
 - 4. Siltation, pollution control and construction entrances.
 - 5. Maintenance of all services through the Project area, including deliveries and emergency vehicles.
 - 6. Miscellaneous connecting and attachment hardware as required installing new equipment.
 - 7. Transport, shipping, and delivery of all materials and equipment to the project site, undamaged and in new condition. This includes those materials furnished by the Owner.
 - 8. Maintenance of all services through the Project area, including water, storm, garbage pickup, mail delivery, other deliveries and emergency vehicles.
 - 9. Minor grading of fill materials as required to match existing grades and maintain positive surface drainage.
 - 10. Minor changes in grades to fit field conditions.

1.2 MOBILIZATION (Pay Item No. 01505.1) PRICE BASED ON LUMP SUM

- A. Measurement for payment for Mobilization shall be based upon the completion of the entire WORK as a Lump Sum Pay unit, complete, in accordance with the requirements of the Contract Documents.
- B. Payment for Mobilization under the Base Bid shall be made at the amount shown under Pay Item No. 01505.1, which payment shall constitute full compensation for all WORK described in Section 01505 - Mobilization, as shown on the plans and as directed by the OWNER.

SECTION 01025 - MEASUREMENT AND PAYMENT

- C. Partial payments will be made as the WORK progresses as follows:
1. CONTRACTOR may submit cost of securing Bonds at time of Agreement, as a portion of mobilization.
 2. When 5% of the total original contract amount is earned from other pay items, 50% of the amount bid for Mobilization, or 5% of the original contract amount, whichever is lesser, will be paid.
 3. When 10% of the total original contract amount is earned from other pay items, 100% of the amount bid for Mobilization, or 10% of the original contract amount, whichever is lesser, will be paid.
 4. Upon completion of all WORK on the Project, payment of any amount bid for Mobilization in excess of 10% of the total original contract amount will be paid.
- 1.3 BASE COURSE (Pay Item No. 2204.1) PRICE BASED ON QUANTITY, CUBIC YARD
- A. Measurement for payment for Base Course shall be based on the number of cubic yards of base course in place as determined by truck load count.
 - B. Preparing subgrade with geofabric, compaction, and grading will be considered incidental to this work under Section 02202- Excavation and Fill.
 - C. Payment for Base Course under the Base Bid shall be made at the Unit Price named in the Bid Schedule under Pay Item No. 2204.1, which payment shall constitute full compensation for all WORK described 02204- Base Course as shown on the plans and as directed by the OWNER.
- 1.4 DEMOLITION (Pay Item No. 2220.1) PRICE BASED ON LUMP SUM
- A. Measurement for payment for Demolition shall be based upon the completion of the entire WORK as a Lump Sum Pay unit, complete, in accordance with the requirements of the Contract Documents.
 - B. Cutting and removal of asphalt and concrete pavements, base course, sub base, metal guardrail and other site appurtenances are part of this pay item.
 - C. Payment for Demolition under the Base Bid shall be made at the Lump Sum Price named in the Bid Schedule under Pay Item No. 2220.1, which payment shall constitute full compensation for all WORK described in Section 2220.1-Demolition, as shown on the plans and as directed by the OWNER.
- 1.5 CONCRETE PAVEMENT (Pay Item No. 3301.01) PRICE BASED ON QUANTITY, CUBIC YARD
- A. Measurement for payment for Concrete Pavement will be based on the actual amount of ground surface covered as measured by area pavement limits in accordance with the limits shown on the Plans or as otherwise directed by the OWNER. Forming,

SECTION 01025 - MEASUREMENT AND PAYMENT

saw cuts, compaction, joint materials and sealing shall be considered incidental and shall not be measured for direct payment.

- B. Pavement installed without the direction and approval of the OWNER shall not be measured for payment.
 - C. Payment for Concrete Pavement will be made at the Unit Price named in the Bid Schedule under Items 3301.01, which payment will constitute full compensation for all WORK described in SECTION 03301 – CONCRETE PAVEMENT, as shown on the Plans and as directed by the OWNER.
- 1.6 HANDRAIL AND RAILINGS (Pay Item No. 5520.01) PRICE BASED ON QUANTITY, LINEAL FEET
- A. Measurement for payment for Handrail and Railings will be based on the lineal feet of guardrail installed in accordance with the limits shown on the Plans or as otherwise directed by the OWNER. Anchoring and fastening shall be considered incidental and shall not be measured for direct payment.
 - B. Payment for Handrail and Railings will be made at the Unit Price named in the Bid Schedule under Items 5520.01, which payment will constitute full compensation for all WORK described in SECTION 05520 – HANDRAIL AND RAILINGS, as shown on the Plans and as directed by the OWNER.

END OF SECTION

SECTION 01045 - CUTTING AND PATCHING

PART 1 - GENERAL

1.1 DEFINITION

- A. "Cutting and Patching" is defined to include the cutting and patching of nominally completed and previously existing asphalt, concrete, steel, wood and miscellaneous metal structures; piping and pavement, in order to accommodate the coordination of WORK, or the installation of other facilities or structures or to uncover other facilities and structures for access or inspection, or to obtain samples for testing, or for similar purposes.

1.2 REQUIREMENTS OF STRUCTURAL WORK

- A. Structural WORK shall not be cut and patched in a manner resulting in a reduction of load-carrying capacity or load/deflection ratio.
- B. Prior to cutting and patching the following categories of WORK, the CONTRACTOR shall obtain the OWNER's approval to proceed with:
 - 1. Structural steel
 - 2. Miscellaneous structural metals, including equipment supports, and similar categories of work
 - 3. Structural asphalt and concrete
 - 4. Foundation construction including piles
 - 5. Bearing and retaining walls

1.3 OPERATIONAL AND SAFETY LIMITATIONS

- A. The CONTRACTOR shall not cut and patch operational elements and safety-related components in a manner resulting in a reduction of capacities to perform in the manner intended or resulting in decreased operational life, increased maintenance, or decreased safety.
- B. Prior to cutting and patching the following categories of WORK, the CONTRACTOR shall obtain the OWNER's approval to proceed with:
 - 1. Sheeting, shoring and cross bracing
 - 2. Operating systems and equipment
 - 3. Water, moisture, vapor, air, smoke barriers, membranes and flashing
 - 4. Noise and vibration control elements and systems
 - 5. Control, communication, conveying and electrical wiring systems

1.4 VISUAL REQUIREMENTS

- A. The CONTRACTOR shall not cut and patch WORK which is exposed on the exterior or exposed in occupied spaces, in a manner resulting in a reduction of visual qualities or resulting in substantial evidence of the cut and patch work, both as judged solely by the OWNER. The CONTRACTOR shall remove and replace work judged by the OWNER to have been cut and patched in a visually unsatisfactory manner.

1.5 APPROVALS

SECTION 01045 - CUTTING AND PATCHING

- A. Where prior approval of cutting and patching is required, the CONTRACTOR shall submit the request and obtain approval prior to performing the WORK. The request should include a description of why cutting and patching cannot reasonably be avoided; how it will be performed; how structural elements (if any) will be reinforced; products to be used; firms and tradespeople who will perform the WORK; approximate dates of the WORK; and anticipated results in terms of structural, operational, and visual variations from the original WORK.

PART 2 - PRODUCTS

2.1 MATERIALS USED IN CUTTING AND PATCHING

- A. Except as otherwise indicated, the CONTRACTOR shall provide materials for cutting and patching which will result in equal-or-better WORK than the WORK being cut and patched, in terms of performance characteristics and including visual effects where applicable. The CONTRACTOR shall use material identical with the original materials where feasible.
- B. Materials shall comply with the requirements of the Technical Specifications wherever applicable.

PART 3 - EXECUTION

3.1 PREPARATION

- A. The CONTRACTOR shall provide adequate temporary support for WORK to be cut to prevent failure.
- B. The CONTRACTOR shall provide adequate protection of other WORK during cutting and patching.

3.2 INSTALLATION

- A. The CONTRACTOR shall employ skilled tradespeople to perform cutting and patching. Except as otherwise indicated, the CONTRACTOR shall proceed with cutting and patching at the earliest feasible time and perform the WORK promptly.
- B. The CONTRACTOR shall use methods least likely to damage WORK to be retained and WORK adjoining.
 - 1. In general, where physical cutting action is required, the CONTRACTOR shall cut WORK with sawing and grinding tools, not with hammering and chopping tools. Openings through concrete work shall be core-drilled and all final edges shall be ground smooth to prevent wear.
 - 2. Comply with the requirements of Technical Specifications wherever applicable.
 - 3. Comply with the requirements of applicable sections of Division 2 where cutting and patching requires excavation and backfill.

SECTION 01045 - CUTTING AND PATCHING

- C. The CONTRACTOR shall patch with seams which are as invisible as possible and comply with specified tolerances for the WORK.
- D. The CONTRACTOR shall restore exposed seams of patched area; and, where necessary, extend finish restoration onto retained WORK adjoining, in a manner which will eliminate evidence of patching.

END OF SECTION

SECTION 01400 - QUALITY CONTROL

PART 1 - GENERAL

1.1 DEFINITION

- A. Specific quality control requirements for the WORK are indicated throughout the Contract Documents. The requirements of this Section are primarily related to performance of the WORK beyond furnishing of manufactured products. The term "Quality Control" includes inspections, sampling and testing, and associated requirements.

1.2 INSPECTION AT PLACE OF MANUFACTURE

- A. Unless otherwise indicated, all products, materials, and equipment shall be subject to inspection by the ENGINEER at the place of manufacture.
- B. The presence of the ENGINEER at the place of manufacturer, however, shall not relieve the CONTRACTOR of the responsibility for furnishing products, materials, and equipment which comply with all requirements of the Contract Documents. Compliance is a duty of the CONTRACTOR, and said duty shall not be avoided by any act or omission on the part of the ENGINEER.

1.3 SAMPLING AND TESTING

- A. Unless otherwise indicated, all sampling and testing shall be in accordance with the methods prescribed in the current standards of the ASTM, ATM, and AASHTO as applicable to the class and nature of the article or materials considered; however, the OWNER reserves the right to use any generally-accepted system of sampling and testing which, in the opinion of the OWNER will insure that the quality of the workmanship is in full accord with the Contract Documents.
- B. Any waiver by the OWNER of any specific testing or other quality assurance measures, whether or not such waiver is accompanied by a guarantee of substantial performance as a relief from the specified testing or other quality assurance requirements as originally specified, and whether or not such guarantee is accompanied by a performance bond to assure execution of any necessary corrective or remedial WORK, shall not be construed as a waiver of any requirements of the Contract Documents.
- C. Notwithstanding the existence of such waiver, the OWNER reserves the right to make independent investigations and tests, and failure of any portion of the WORK to meet any of the requirements of the Contract Documents, shall be reasonable cause for the OWNER to require the removal or correction and reconstruction of any such work in accordance with the General Conditions.

PART 2 - PRODUCTS (Not Used)

PART 3 - EXECUTION

3.1 INSTALLATION

SECTION 01400 - QUALITY CONTROL

- A. Inspection: The OWNER will appoint, employ and pay for services to inspect materials or equipment upon the arrival on the job site and immediately prior to installation, and reject damaged and defective items.
- B. Measurements: The CONTRACTOR shall verify measurements and dimensions of the WORK, as an integral step of starting each installation.
- C. Manufacturer's Instructions: Where installations include manufactured products, the CONTRACTOR shall comply with manufacturer's applicable instructions and recommendations for installation, to whatever extent these are more explicit or more stringent than applicable requirements indicated in Contract Documents.

END OF SECTION

SECTION 01505 - MOBILIZATION

PART 1 - GENERAL

1.1 GENERAL

- A. Mobilization shall include the obtaining of all permits; moving onto the site of all plant and equipment; furnishing and erecting plants, temporary buildings, and other construction facilities; and implementing security requirements; all as required for the proper performance and completion of the WORK. Mobilization shall include the following principal items:
1. Moving on to the site of all CONTRACTOR's plant and equipment required for operations.
 2. Providing all on-site communication facilities, including radios and cellular phones.
 3. Obtaining all required permits.
 4. Having all OSHA required notices and establishment of safety programs.
 5. Having the CONTRACTOR's superintendent at the job site full time.
 6. Submitting initial submittals.

1.2 PAYMENT FOR MOBILIZATION

- A. As soon as practicable after receipt of the Notice to Proceed, the CONTRACTOR shall submit a breakdown to the OWNER for approval, which shall show the estimated value of each major component of Mobilization. When approved by the OWNER, the breakdown will be the basis for initial progress payments in which Mobilization is included.

PART 2 – PRODUCTS (Not Used)

PART 3 – EXECUTION (Not Used)

END OF SECTION

SECTION 01700 - PROJECT CLOSE-OUT

PART 1 – GENERAL

- 1.1 FINAL CLEAN-UP. The CONTRACTOR shall promptly remove from the vicinity of the completed work, all rubbish, unused materials, concrete forms, construction equipment, and temporary structures and facilities used during construction. Final acceptance of the WORK by the OWNER will be withheld until the CONTRACTOR has satisfactorily complied with the foregoing requirements for final clean-up of the project site.
- 1.2 CLOSEOUT TIMETABLE. The CONTRACTOR shall establish dates for acceptance periods, and on-site instructional periods (as required under the Contract). Such dates shall be established not less than one week prior to beginning any of the foregoing items, to allow the OWNER and their authorized representatives sufficient time to schedule attendance at such activities.
- 1.3 FINAL SUBMITTALS. The CONTRACTOR, prior to requesting final payment, shall obtain and submit the following items to the ENGINEER for transmittal to the OWNER:
- A. Written guarantees, where required.
 - B. Completed record drawings.
 - C. Certificates of inspection and acceptance by governing agencies having jurisdiction.
 - D. Releases from all parties who are entitled to claims against the subject Project, property, or improvement pursuant to the provisions of law.
 - E. Completed Certificate of Compliance and Release for all contractors involved in the WORK. Submit the original signed document to the OWNER's Project Manager.
- 1.4 MAINTENANCE AND GUARANTEE
- A. The CONTRACTOR shall comply with the maintenance and guarantee requirements contained in Article 13 of the General Conditions.
 - B. The CONTRACTOR shall make all repairs and replacements promptly upon receipt of written order from the OWNER. If the CONTRACTOR fails to make such repairs or replacements promptly, the OWNER reserves the right to do the WORK and the CONTRACTOR and his surety shall be liable to the OWNER for the cost thereof.
- 1.5 BOND. The CONTRACTOR shall provide a bond to guarantee performance of the provisions contained in Paragraph "Maintenance and Guarantee" above, and Article 13 of the General Conditions.

PART 2 - PRODUCTS (Not Used)

PART 3 - EXECUTION (Not Used)

END OF SECTION

SECTION 01704 - FINAL CLEAN-UP AND SITE RESTORATION

PART 1 - GENERAL

- 1.1 DESCRIPTION. The WORK under this Section includes providing all supervision, labor, materials, tools and equipment necessary for final clean-up and restoration of all areas disturbed by construction activities, to a condition equal to, or better than, before construction started. This does not include clean-up or restoration incidental to, or directly provided for by, other construction items.

PART 2 - PRODUCTS

- 2.1 MATERIALS. Any materials required shall conform to the appropriate Section of these Specifications.

PART 3 - EXECUTION

3.1 CONSTRUCTION

- A. The CONTRACTOR shall clean up all sites disturbed during construction of the project. This includes removal of all construction equipment, disposal of all excess materials, disposal of all rubbish and debris, removal of all temporary structures, and grading of the sites so that no standing water is evident.
- B. Excess concrete supply shall not be disposed of on site without approval of the OWNER.

END OF SECTION

SECTION 02204 - BASE COURSE

PART 1- GENERAL

1.1 DESCRIPTION

- A. The WORK under this section includes providing all labor, materials, tools and equipment necessary for furnishing and placing one or more layers of aggregate base on a prepared subgrade to the lines and grades shown on the Plans.

1.2 SUBMITTALS

- A. D-1 Base Course.

PART 2- PRODUCTS

2.1 MATERIAL

- A. Aggregate base course shall consist of crushed gravel or crushed stone, conforming to the quality requirements of AASHTO M 147. The aggregate shall be free from lumps, balls of clay, or other objectionable matter, and shall be durable and sound.

1. Base course shall be sampled according to "WAQTC FOP for AASHTO T2 – Sampling Aggregates" as described in the *Alaska Test Methods Manual*, published by the Alaska Department of Transportation and Public Facilities.
2. Coarse aggregate (that material retained on the No. 4 sieve) shall be crushed stone and shall consist of sound, tough, durable rock of uniform quality. Rock shall be free of schist that cleaves along preferred foliation planes. Rock shall be free of platy mineral grains. Metamorphosed rock shall be free of slaty cleavage. All material shall be free from clay balls, vegetable matter or other deleterious matters. Coarse aggregate shall not be coated with dirt or other finely divided mineral matter. All aggregates shall be free of roots and wood. In addition, coarse aggregate shall meet the following requirements:

Property	Value	Test Method
L.A. Wear, %	25 max.	AASHTO T 96
Degradation Value	No minimum value	ATM 313
Fracture, %	70 min.	WAQTC FOP for AASHTO TP 61
Sodium Sulfate Loss, %	9 max.	AASHTO T 104

3. Aggregate shall not exceed eight (8) percent thin -elongated pieces as determined by ATM 306.
 4. Fine Aggregate: Fine aggregate (passing the No. 4 sieve) shall meet the quality requirements of AASHTO M 29.
- B. Base course material shall conform to one of the following gradations as specified:

SECTION 02204 - BASE COURSE

BASE COURSE GRADATIONS
(Percent passing by weight)

<u>Sieve Designation</u>	<u>A</u>	<u>B</u>	<u>C</u>	<u>C-1</u>	<u>D</u>	<u>D-1</u>	<u>E</u>	<u>E-1</u>
4	100							
2	85-100	100						
1 1/2				100				
1			100	70-100		100		
3/4				60-90	100	70-100		100
3/8				45-75		50-80		
No. 4	30-60	30-70	40-75	30-60	45-80	35-65		45-80
No. 8				22-52		20-50		32-80
No. 10			25-55		30-65			
No. 40				8-30		8-30		
No. 200	0-6	3-10	4-10	0-6	4-12	0-6	0-6	0-6

- C. For gradings A, C-1, D-1 & E-1, at least 70% by weight of the particles retained on a No. 4 sieve shall have at least one fractured face as determined by Alaska T-4.

PART 3- EXECUTION

3.1 CONSTRUCTION

- A. Prior to placement of the base course, the underlying surface shall be excavated to limits shown. A layer of geofabric will be placed below the aggregate, prior to preparation by dressing, shaping, wetting or drying, and compacting of the base course material. Surfaces shall be cleaned of all foreign substances and debris.
- B. Any ruts or soft yielding spots that may appear shall be corrected by loosening and removing unsatisfactory material and adding approved material as required, reshaping, and recompacting the affected areas to the lines and grades indicated on the plans. If required by the OWNER, the CONTRACTOR shall proof load questionable areas with a loaded truck or other piece of equipment approved by the OWNER.
- C. Base course material shall be deposited and spread in a uniform layer to the required grades, and to such loose depth that when compacted to the density required, the thickness will be as indicated on the plans. Portions of the layer which become segregated shall be removed and replaced with a satisfactory mixture, or shall be remixed to the required gradation.
- D. The maximum compacted thickness of any one layer shall not exceed six inches. If the required compacted depth exceeds six inches, the base shall be constructed in two or more layers of approximately equal thickness. Each layer shall be shaped and compacted before the succeeding layer is placed.
- E. The base course shall be compacted to at least 95% of maximum density as determined by AASHTO T 180-D. In places not accessible to rolling equipment, the mixture shall be compacted with hand tamping equipment.

SECTION 02204 - BASE COURSE

- F. Blading, rolling, and tamping shall continue until the surface is smooth and free from waves and irregularities. If at any time the mixture is excessively moistened, it shall be aerated by means of blade graders, harrows, or other approved equipment, until the moisture content is such that the surface can be recompacted and finished as above.
- G. The finished surface of the base course, when tested using a 10-foot straightedge, shall not show any deviation in excess of 3/8-inch between two contact points. The finish surface shall not vary more than 1/2-inch from established grade. Additionally, the algebraic average of all deviations from established grade of the finish base course surface elevations taken at 50-foot intervals shall be less than 0.02-foot.
- H. The initial density test at any location will be paid for by the OWNER. If the initial test shows that the material compaction is not as specified, the CONTRACTOR shall modify the compaction methods used, as approved by the OWNER, and have the material retested until the tests show that the compaction meets the specification requirements. All tests, after the initial test at any given location, shall be paid for by the CONTRACTOR.

3.2 FIELD QUALITY CONTROL

- A. Compaction Testing: As determined by AASHTO T310 and T224.
- B. Tests shall be conducted once for every 200 cubic yards of material placed.

END OF SECTION

SECTION 02220- DEMOLITION

PART 1- GENERAL

1.1 DESCRIPTION

- A. Work in this section includes demolition and removal of site improvements and pavements, filling holes and grading area of demolition.

1.2 SUBMITTALS

- A. Record Drawings:
 - 1. Accurately record actual locations of pipe runs, connections, and invert elevations. Identify and accurately locate capped utilities and other subsurface structural, electrical, or mechanical conditions encountered.
 - 2. Identify and describe unexpected variations to subsoil conditions or discovery or uncharted utilities.

PART 2- PRODUCTS

- 2.1 Not Used.

PART 3- EXECUTION

3.1 EXAMINATION

- A. Survey the condition of utilities, site improvements and pavements to determine whether removing any element might result in structural deficiency or unplanned collapse of any portion of adjacent structures during demolition.
- B. Perform surveys as the Work progresses to detect hazards resulting from demolition activities.

3.2 PREPARATION

- A. Protect elements surrounding Work of this section from damage or disfiguration.
- B. Protect existing utility structures from damage and disturbance. Provide shoring to support existing utilities and their support prism or remove and replace utilities where shoring is not practical. Removing and replacing to be performed per utility owner's standards.
- C. Existing to Remain: Protect construction to remain against damage and soiling during demolition. When permitted by the OWNER, items may be removed to suitable, protected storage location during demolition then cleaned and reinstalled in original locations.

- D. Erect barriers and barricades to direct and protect adjacent traffic.
- E. Locate existing utilities; avoid damage or disturbance. For aid in utility location call “Public Works”, at 907-874-3904, 48-hours (two working days) prior to beginning construction.
- F. Drain, purge, or otherwise remove, collect, and dispose of chemicals, gases, explosives, acids, flammables, or other dangerous materials before proceeding with demolition operations.

3.3 DEMOLITION

- A. Demolish improvements as directed on the plans.
- B. Conduct demolition operations and remove debris to ensure minimum interference with roads, streets, sidewalks, and other adjacent occupied and used facilities. Do not close or obstruct streets, walks, or other adjacent occupied or used facilities without permission from OWNER. Provide alternate routes around closed or obstructed traffic way if required.
- C. Conduct demolition operations to prevent injury to people and damage to adjacent facilities to remain. Ensure safe passage of people around demolition area.
- D. Explosives: Use of explosives will not be permitted.
- E. Damages: Promptly repair damages to adjacent facilities caused by demolition operations.
- F. Pavement Demolition:
 - 1. Saw cut pavement at edge of sections to remain. Construct neat straight lines.
 - 2. Break up pavement to be removed and dispose.
- H. Filling Depressions and Grading:
 - 1. Fill depressions and holes with base course and compact material to 95 percent.
 - 2. Grade and shape area within limits of Work indicated on Drawings to provide drainage.

3.4 CLEANING

- A. Dispose of surplus or unsuitable material.
- B. Dispose of waste, surplus, and unsuitable materials according to laws, regulations, and ordinances off-site at a site obtained by Contractor.

END OF SECTION

SECTION 03301 – CONCRETE PAVING

PART 1 - GENERAL

1.1 DESCRIPTION

- A. The WORK under this Section shall include all labor, materials, tools, and equipment necessary for furnishing and installing of cement concrete pavement for sidewalks with curb and gutter and associated backfill and grading, in accordance with these specifications and in reasonably close conformity with the lines, grades, details, and locations shown on the plans or established by the OWNER.

1.2 REFERENCES

- A. ASTM (American Society of Testing Materials) Specifications
- B. ACI (American Concrete Institute) Code
- C. AWS (American Welding Society) D1.4 – Reinforcing Steel
- D. ASTM A615 – Deformed and Plain Billet-Steel Bars for Concrete Reinforcement
- E. ASTM A706 - Low Alloy Steel Deformed Bars for Concrete Reinforcement
- F. ASTM C150 – Portland Cement
- G. ASTM C33 – Concrete Aggregates
- H. ACI 301 – Structural Concrete for Buildings
- I. ACI 304 – Recommended Practice for Measuring, Mixing Transporting and Placing Concrete
- J. ACI 306R – Cold-Weather Concreting
- K. ACI 308 – Standard Practice for Curing Concrete
- L. ACI 309 – Standard Practice for Consolidation of Concrete
- M. ACI 318 – Building Code Requirements for Reinforced Concrete
- N. ACI 347 – Recommended Practice for Concrete Formwork

1.3 SUBMITTALS

- A. Concrete Mix Design.
- B. Joint Sealant and Backer Rod.
- C. Construction Joint Layout: Indicate proposed construction joints required to construct the pavement. Location of construction joints is subject to Owner approval.

1.4 QUALITY ASSURANCE

SECTION 03301 – CONCRETE PAVING

- A. Concrete quality control testing shall be provided by an independent third party and paid for by the CONTRACTOR. Quality control reports shall be provided to the OWNER after each pour and cylinder test.
- B. Air content (ASTM C173), slump (ASTM C143), unit weight (ASTM C138) and compressive strength cylinders (ASTM C31) shall be sampled and tested every 50 cubic yards of each pour.
- C. Two compressive strength cylinders shall be collected at each sample. One shall be tested at 7 days and one shall be tested at 14 days. Cylinders shall be cured per ASTM C31 procedures.

PART 2 - PRODUCTS

2.1 MATERIALS

- A. Portland Cement shall conform to the requirements of AASHTO M 85.
- B. Aggregate shall be clean, durable, uniformly graded sand and gravel, or crushed stone.
- C. Air-entraining admixtures shall conform to the requirement of AASHTO M 154.
- D. Concrete shall meet the following requirements:
 - ASTM C150, Type I or II cement
 - Compressive Strength 4,000 psi minimum at 28-day strength
 - Slump Range 3" – 5"
 - Entrained Air Range 6%-8%
 - Reinforcing shall be with Sika® Fibermesh®-150, or approved equal, with dosage ration of between 0.75 - 1.5 lbs/cu yd (0.5 - 0.9 kg/m³) of concrete.
- E. The concrete shall be subject to acceptance or rejection by visual inspection at the job site. Retempering concrete will not be permitted.

2.2 CONCRETE SEALER

- A. Concrete Sealer, Chem-Crete Sofix CCC100, or equal, as provided by Owner, and installed in the project by Contractor, shall be used as a concrete curing and waterproofing sealer system. The concrete sealer shall be applied to the concrete paving prior to opening the surface to traffic.

2.3 FORMWORK

- A. Forms shall be designed and constructed to be removed without injuring the concrete. They shall be free of bulge and warp and constructed so the finished concrete will be of the form and dimensions shown on the Plans, and true to line and grade. Forms for concrete containing a retarding admixture shall be designed for a lateral pressure equal to that exerted by a fluid weighing 150 pounds per cubic foot.

SECTION 03301 – CONCRETE PAVING

2.4 RELATED MATERIALS

- A. Expansion- and Isolation-Joint-Filler Strips: ASTM D 1751, asphalt-saturated cellulosic fiber or ASTM D 1752, cork or self-expanding cork.
- B. Expansion Joint Sealant: Sikaflex 1A Polyurethane Premium Grade High Performance Elastomeric Sealant
- C. Weathermate Sill Seal by the Dow Chemical Company or approved equal shall be used as a filler strip for expansion joints at slab penetrations of less than 24 inch diameter.
- D. Curing Materials shall confirm to one of the following requirements:
 - 1. Burlap Cloth made from Jute Kenaf AASHTO M 182
 - 2. Sheet Material for Curing Concrete AASHTO M 171
 - 3. Liquid Membrane Forming Compounds AASHTO M 148 for Curing Concrete, Type I
- E. The requirements specified in AASHTO M 148 covering "Liquid Membrane Forming Compounds for Curing Concrete" are modified by adding the following:

Liquid membrane forming compounds utilizing linseed oil shall not be used.

PART 3 – EXECUTION

3.1 CUTTING

- A. All asphalt and concrete pavement removal shall be precut to a neat line using a power-driven saw.

3.2 INSTALLATION

- A. Mixing: Mix in accordance with proportions specified in the Concrete Mix Design submitted by the CONTRACTOR and approved by the OWNER. Concrete shall be mixed in a batch mixer of acceptable size and type which will ensure a uniform distribution of materials throughout the mix so as to produce a homogeneous mix, uniform in color. All concrete shall be placed within one hour after water is first added to the batch. The mixer shall be cleaned at frequent intervals while in use.
- B. Placing Concrete:
 - 1. Notify OWNER a minimum of 24 hours prior to commencement of operations.
 - 2. Subgrade shall be constructed and compacted true to grades shown on the drawings. All soft or unsuitable material shall be removed to a depth of not less than six inches below subgrade elevation and replaced with material satisfactory to the OWNER. Removal and replacement of soft or unsuitable materials will not be paid for as extra work.
 - 3. Place concrete in accordance with ACI 304 and as herein specified. Place concrete continuously or in layers of such thickness that no concrete has hardened or set sufficiently to cause the formation of cold joints, seams or planes of weakness.

SECTION 03301 – CONCRETE PAVING

4. Extra vibrating shall be done along all faces to obtain smooth surfaces. Care shall be taken to prevent mortar from splattering on forms and reinforcing steel and from drying ahead of the final covering with concrete.
5. Remove water and debris from concrete form work prior to placing concrete.
6. Place concrete as nearly as practicable to its final position to avoid segregation due to excessive drop and rehandling.
7. Do not use concrete which becomes non-plastic and unworkable and does not meet the required quality control limits or has been contaminated by foreign materials.
8. Remove rejected concrete from the site.

C. Equipment:

1. Provide adequate number of mechanically maintained equipment, including spare units, to ensure completion of concrete placement, as required, without delay or stopping.

D. Finishing:

1. Joints shall be constructed in a straight line, vertical plane and perpendicular to the longitudinal line of the sidewalk, curb, and gutter. Curb and gutter joints shall match the location of concrete pavement joints when abutting concrete pavement.
2. Expansion Joints shall be used where the new sidewalk abuts an existing structure or concrete structure and no greater than every fifteen feet. The expansion joint material shall extend fully through the concrete and one inch into the subgrade with the top of the expansion joint material one-quarter inch below the top surface. Expansion joint material shall be secured in place prior to placement of concrete, shall run the full depth of the void, and shall be capped with a polyurethane sealant.
3. Control Joints, or contraction joints, shall be placed no greater than every five feet by either a tooled/grooved method while concrete is still plastic, or a wet-cut sawcut method within four to twelve hours after finishing. Control joints shall be ¼" deep.
4. All finished or formed surfaces shall accurately conform to the shape, alignment, grades, and sections as shown of the Plans.
5. Provide light broom finish on surfaces of sidewalk, curb and gutter, transverse to primary traffic on all horizontal surfaces.

E. Curing and Protection:

1. Cure and protect concrete in accordance with ACI 308, ACI 306R and as herein specified.
2. Immediately after placement, protect concrete from premature drying and physical damage. No concrete shall be placed during a rain event unless acceptable protective shelter is provided.
3. Maintain concrete with minimal moisture loss and at relatively constant temperature for period of time necessary for sufficient hydration of cement and hardening of concrete.
4. Concrete shall be kept continually wet while curing by applying water over the curing concrete slab a minimum of twice a day. The curing concrete slab shall be covered with burlap or other approved material for at least 7 days if Type I or Type II cement is used or for at least 3 days if Type III cement is used.
5. Wood forms allowed to remain in place during the curing period shall be kept moist at all times.
6. Liquid membrane curing compound may be permitted, subject to approval of manufacturer's product data. Apply in strict accordance with manufacturer's

SECTION 03301 – CONCRETE PAVING

instructions. Maintain moisture cure procedures prior to application of approved curing compound. Repair marred or damaged membrane immediately.

7. Protect all fresh concrete from vibrations due to compaction of adjacent earthwork until the fresh concrete has reached a min 80% of its compressive capacity.
 8. Protect fresh and curing concrete from ambient temperatures less than 40°F.
- F. Defective concrete consists of concrete not conforming to mix design, required lines, grades, details, dimensions, tolerances, or other specified requirements. Repair or replacement of defective concrete shall be determined by the OWNER. Defective concrete shall be repaired and/or replaced at no additional cost to the OWNER. Repair all concrete cracks greater than 0.007" wide with Euco Qwikstich crack repair product or approved equal.
- G. CONTRACTOR shall protect adjacent fill materials from erosion at all times during construction of the concrete slab. Any eroded materials shall be replaced at no additional cost to the OWNER.
- H. Apply sealer coat to finished concrete surface per manufactures recommendations.

3.2 SEALANT ACCESSORIES

- A. General: Provide joint backings, fillers, or primers as recommended by joint sealant manufacturer.
- B. Cylindrical Sealant Backings: Provide joint backings that meet ASTM C-1330, Type O (open-cell polyurethane) or Type B (non-absorbent bi-cellular backing materials with surface skin) sized 25% or greater than joint opening with proper density to control sealant depth and profile. Follow joint sealant manufacturer's recommendations with backing selections for optimum joint sealant performance.
- C. Bond-breaker tape: Polyethylene tape or other approved plastic tape as recommended by joint sealant manufacturer to prevent 3-sided joint adhesion to rigid, in-flexible joint fillers or file joint surfaces at back of joint where such adhesion would restrict proper sealant movement or result in sealant failure.
- D. Masking tape: Non-staining, non-absorbent and compatible with joint sealants and adjacent surfaces.
- E. Primers: Use primers only as recommended by sealant manufacturer where required for adhesion of sealant to joint substrates indicated and as determined for use from pre-construction mock-up testing.

3.3 SAMPLING AND TESTING

- A. Field tests of all materials will be made by the OWNER, in accordance with the applicable Specifications. When the results of the field tests indicate that the material does not conform to the requirements of the Specifications, the re-tests required by the OWNER shall be at the expense of the CONTRACTOR.

SECTION 03301 – CONCRETE PAVING

- B. Materials that fail to meet contract requirements, as indicated by laboratory tests, shall not be used in the WORK. The CONTRACTOR shall remove all defective materials from the site.
- C. Types and sizes of concrete specimens shall be in accordance with ASTM C 31. Additional slump tests and/or test cylinders may be required at the discretion of the OWNER. Should the analysis of any test cylinder not meet the preceding requirements of the Design Mix its representative concrete shall be removed and replaced at the CONTRACTOR's expense.
- D. Two copies of all test reports shall be furnished to the OWNER.

3.4 BACKFILLING AND OPENING TO TRAFFIC

- A. The front face form shall not be removed before the concrete has taken initial set and has sufficient strength to carry its own weight. Gutter forms and rear forms shall not be removed until concrete has hardened sufficiently to prevent damage to the edges. Any portion of concrete damaged while stripping forms shall be repaired or replaced at no additional cost to the OWNER.
- B. Unbalanced backfilling against concrete structures will not be permitted until the concrete has attained a compressive strength of not less than 80% of the ultimate strength ($f'c$) shown on the Plans.
- C. The compressive strength shall be determined from informational test cylinders cured on the site under similar conditions of temperature and moisture as the concrete in the structure.

END OF SECTION

SECTION 05520 – HANDRAIL AND RAILINGS

PART 1 - GENERAL

1.1 DESCRIPTION

- A. The WORK under this Section shall include all labor, materials, tools, and equipment necessary for furnishing and installing of approximately 130 lineal feet of pedestrian guardrail as a fall safety barrier.

1.2 REFERENCES

- A. Americans with Disabilities Act Accessibility Guidelines (ADA).
- B. American National Standards Institute (ANSI) - A21.1 Safety Requirements for Floor and Wall Openings, Railings and Toe Boards.
- C. American National Standards Institute (ANSI) - A58.1 Minimum Design Loads in Buildings and Other Structures.
- D. American National Standards Institute (ANSI) - A17.1 Accessible and Usable Buildings and Facilities.
- E. American Society of Testing and Materials (ASTM) A47 - Standard Specification for Ferritic Malleable Iron Castings.
- F. American Society of Testing and Materials (ASTM) A53 - Standard Specification for Pipe, Steel, Black and Hot-Dipped, Zinc-Coated, Welded and Seamless.
- G. American Society of Testing and Materials (ASTM) A153 - Standard Specification for Zinc Coating (Hot-Dip) on Iron and Steel Hardware.
- H. Occupational Safety & Health Administration (OSHA): 1910.23 - Guarding Floor and Wall Openings and Holes.

1.3 SUBMITTALS

- A. Product Data: Manufacturer's data sheets on each product to be used, including:
 - 1. Preparation instructions and recommendations.
 - 2. Storage and handling requirements and recommendations.
 - 3. Installation methods.
- B. Shop Drawings: Drawings showing fabrication and installation of handrails and guardrails including plans, elevations, sections, details of components, anchor details, and attachment to adjoining units of work.
- C. Selection Samples: For each finish product specified, two complete sets of color chips representing manufacturer's full range of available colors and patterns.

1.4 QUALITY ASSURANCE

SECTION 05520 – HANDRAIL AND RAILINGS

A. Railings Structural Requirements:

1. Handrail, wall rail and guardrail assemblies and attachments shall withstand a minimum concentrated load of 200 pounds (90719 g) applied horizontally or vertically down at any point on the top rail.
2. Infill area of guardrail system capable of withstanding a horizontal concentrated load of 200 pounds (90719 g) applied to one square foot (8165 g/sm) at any point in the system. Load not to act concurrently with loads on top rail of system in determining stress on guardrail.
3. Handrail assemblies and guards shall be designed to resist a load of 50 pounds per linear foot (0.73 kN/m) applied in any direction at the top and to transfer this load through the supports to the structure.

1.5 DELIVERY, STORAGE, AND HANDLING

- A. Materials to be delivered to the job site in good condition and adequately protected against damage as handrails are a finished product.
- B. Store products in manufacturer's unopened packaging until ready for installation.

1.6 PROJECT CONDITIONS

- A. Maintain environmental conditions (temperature, humidity, and ventilation) within limits recommended by manufacturer for optimum results. Do not install products under environmental conditions outside manufacturer's absolute limits.
- B. Field Measurements: Where handrails and railings are indicated to fit to other construction, check actual dimensions of other construction by accurate field measurements before fabrication; show recorded measurements on final shop drawings.
 1. Where field measurements cannot be made without delaying the railing fabrication and delivery, obtain guaranteed dimensions in writing by the Contractor and proceed with fabrication of products to not delay fabrication, delivery, and installation.
- C. Coordinate fabrication and delivery schedule of handrails with construction progress and sequence to avoid delay of railing installation.

PART 2 PRODUCTS

2.1 MANUFACTURERS

- A. Acceptable Manufacturer: Kee Safety, Inc., 100 Stradtman St. Buffalo, NY 14206, Tel: 716-896-4949, Web: www.keeklamp.com, or equal system.

2.2 SYSTEMS

- A. Handrails and Guardrails: Provide pipe, fittings, and accessories as indicated or required to match design indicated on the drawings.

SECTION 05520 – HANDRAIL AND RAILINGS

1. Fittings: Aluminum.
 2. Fittings: Cast iron.
 3. Handrail Pipe Size: 1-1/2 inches (38 mm) - 1.90 inches (48 mm) O D.
 4. Infill Panels: As indicated on drawings.
- B. Safety Barriers: Provide Kwik Kit System, or equal, including pipe railings, uprights, bases, and fittings as indicated or required by drawings to match design indicated.
1. Safety barrier system with 42 inches height to provide a pedestrian barrier to withstand a minimum load of 200 lb (90719 g) in any direction to all components per OSHA Regulation 29 CFR 1910.23.
 2. Pipe: Steel, 1.90 inches OD.
 3. Rails and Posts: Anodized finish.
 4. Fasteners: 304 or 305 stainless steel.
- C. Custom Design: Provide pipe, fittings, and accessories as indicated or required by Drawings to match design indicated.

2.3 MATERIALS

- A. Pipe: Aluminum pipe.
- B. Fittings, Including Elbows, Crossovers, Wall flanges, Tees, Couplings: Aluminum Alloy: High grade aluminum silicon magnesium alloy.
- C. Finish: Polyester factory applied spray coating.
- D. Fasteners: Type 304 or 305 stainless steel.

2.4 FABRICATION

- A. Fit and shop assemble components in largest practical sizes for delivery to site.
- B. Upright tops shall be plugged with weather and light resistant material.
- C. Assemble components with joints tightly fitted and secured. Accurately form components to suit installation.

PART 3 EXECUTION

3.1 EXAMINATION

- A. Do not begin installation until substrates have been properly prepared.

3.2 PREPARATION

- A. Coordinate post setting drawings, diagrams, templates, instructions, and directions for installation of anchorages, such as sleeves, concrete inserts, anchor bolts, and

SECTION 05520 – HANDRAIL AND RAILINGS

miscellaneous items having integral anchors that are to be embedded in concrete and masonry construction.

1. Coordinate delivery of anchorages to project site.
 2. Coordinate that blocking is in place for all mounting fasteners.
- B. Prepare surfaces using the methods recommended by the manufacturer for achieving the best result for the substrate under the project conditions.

3.3 INSTALLATION

- A. Install in accordance with manufacturer's instructions.
- B. Fit exposed connections accurately together to form tight joints. For all connections with Kee Klamp fittings, each set screw is to be tightened to 29-foot pounds (39 N-m) of torque.
- C. Perform cutting, drilling, and fitting required for installation of handrails. Set handrails and accurately in location, alignment, and elevation, measured from established lines and levels.
- D. Set posts plumb within a tolerance of 1/8 inch (3 mm).

3.4 PROTECTION

- A. Protect installed products until completion of project.
- B. Touch-up, repair or replace damaged products before Substantial Completion.

END OF SECTION

Reid Street Sidewalk Replacement

June 2022

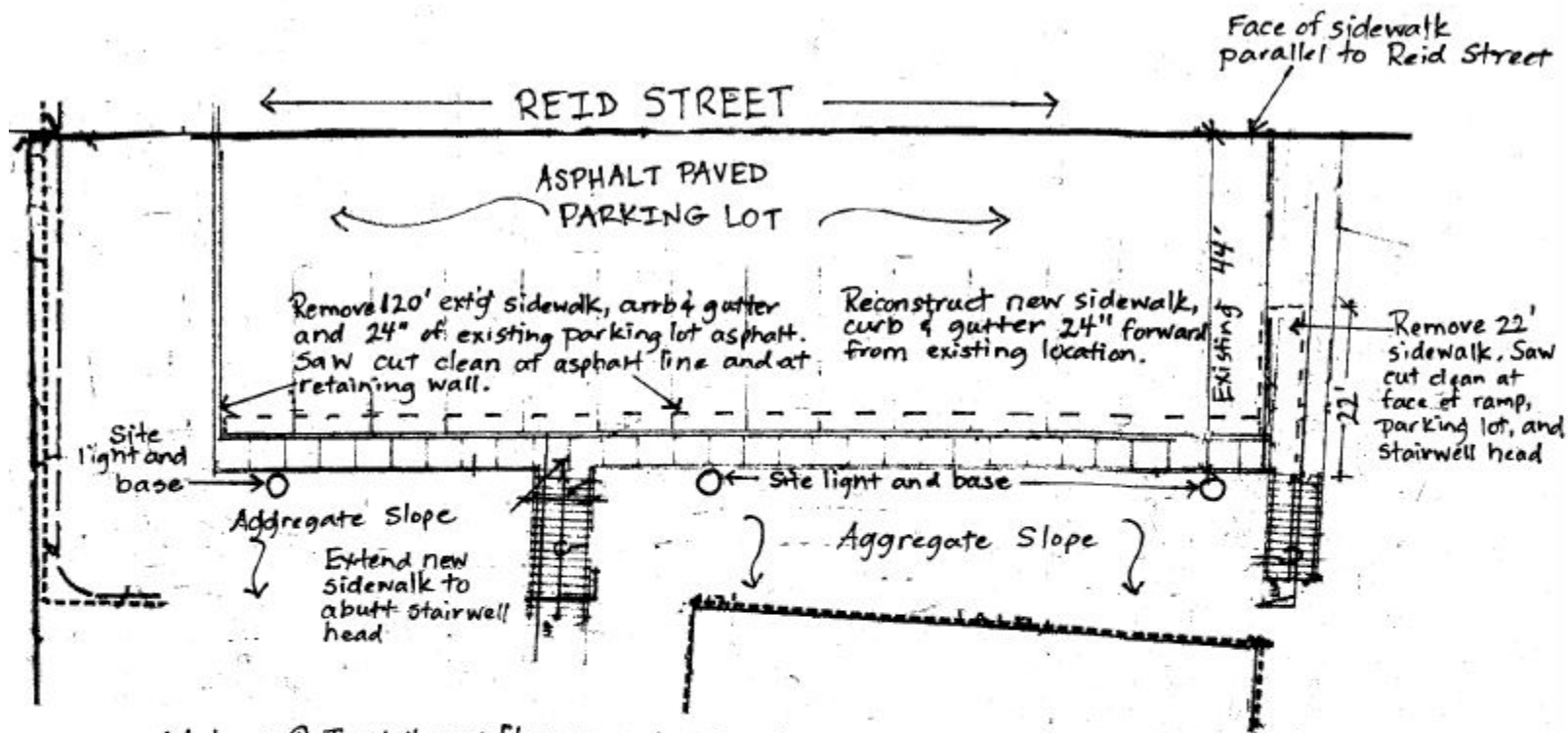

- Notes:
- ① Install new floor-mount pedestrian guardrail at backside of new sidewalk. See Drawing Sheet 5 for details.
 - ② Grade and compact top of Aggregate Slope that is left exposed from forward shift of new sidewalk location. Match existing slope to an elevation level with 3" below top of new sidewalk.
 - ③ Site lights and bases (Qty: 3) shall remain. Existing conduit is exposed between the bases and the existing sidewalk. Contractor shall take care to work around existing electrical conduit and maintain their bury in the new construction.

Reid Street Sidewalk Replacement

June 2022

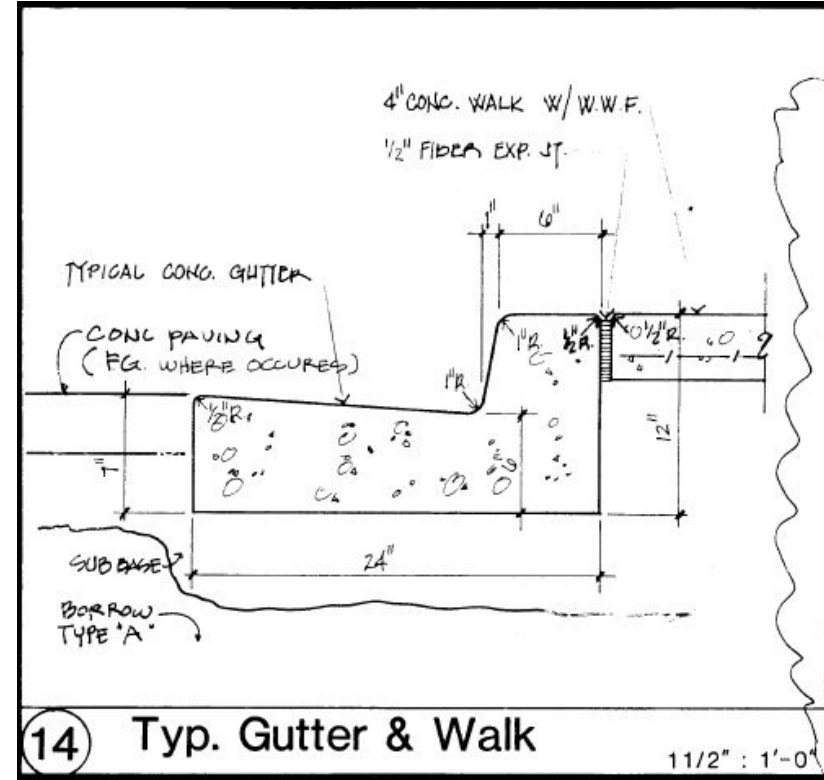
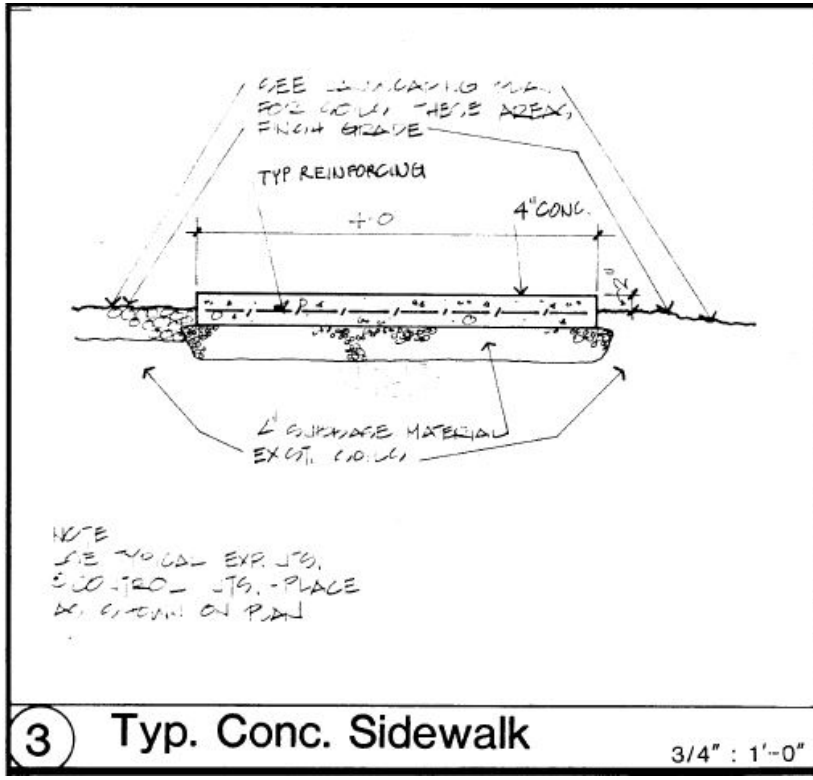

Existing Sidewalk Detail

Existing Curb and Gutter Detail

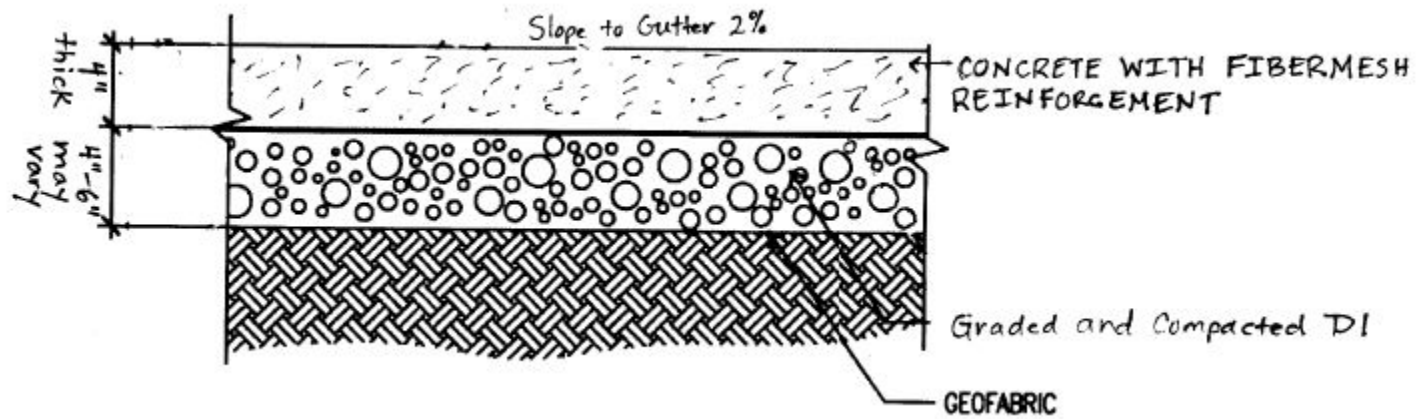

Concrete Sidewalk Paving Detail

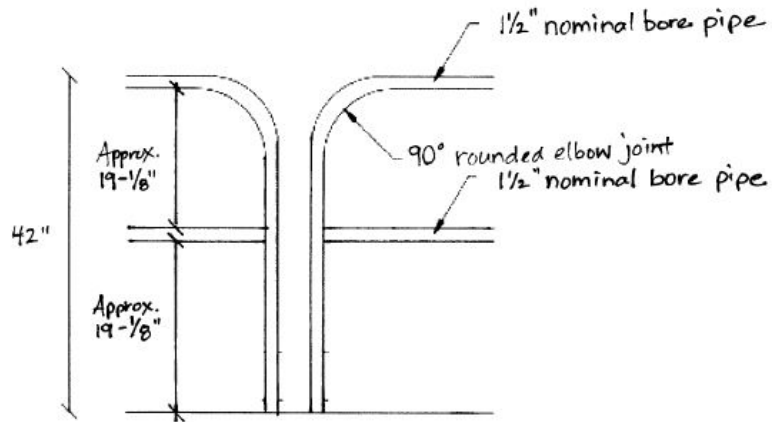

Guardrail Elevation Detail

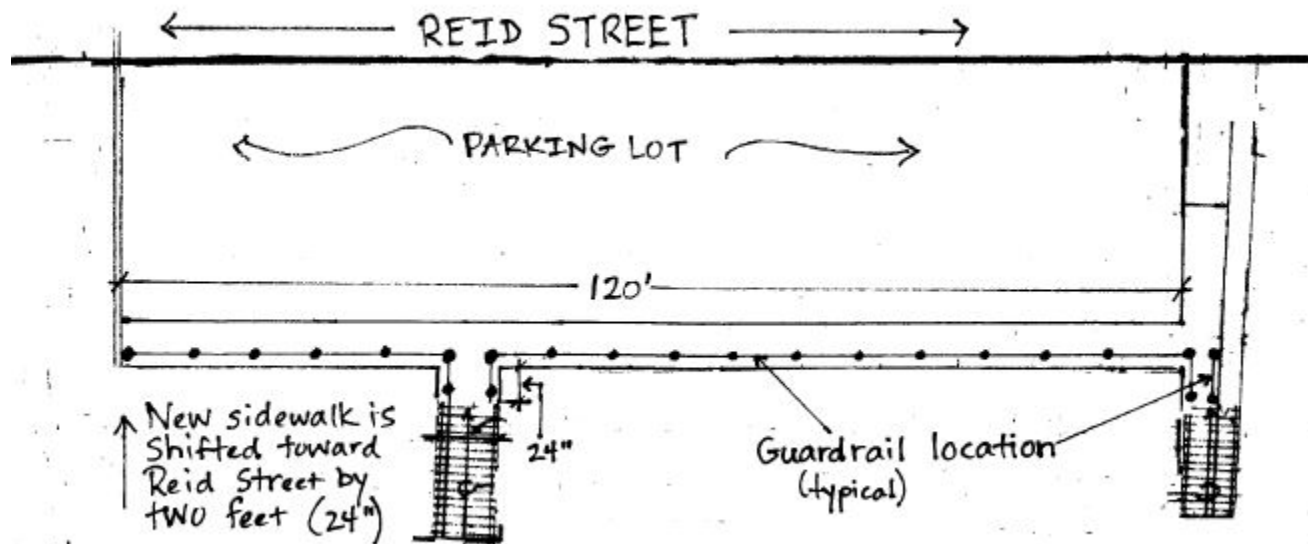

Guardrail Location