

# CITY AND BOROUGH OF WRANGELL



## WRANGELL AIRPORT AIRFIELD LIGHTING BACK-UP POWER CONNECTION

### PROJECT MANUAL

APRIL 2024

**SECTION 00005 - TABLE OF CONTENTS**

**DIVISION 0 - BIDDING AND CONTRACT REQUIREMENTS, CONTRACT FORMS, AND CONDITIONS OF THE CONTRACT**

**BIDDING AND CONTRACT REQUIREMENTS No. of Pages**

00005	Table of Contents .....	1
00030	Notice Inviting Bids .....	2
00100	Instructions to Bidders .....	8
00300	Bid .....	2
00310	Bid Schedule .....	1
00320	Bid Bond .....	1
00360	Subcontractor Report .....	2

**CONTRACT FORMS**

00500	Agreement .....	7
-------	-----------------	---

**CONDITIONS OF THE CONTRACT**

00700	General Conditions .....	46
00800	Supplementary General Conditions .....	2
00830	Alaska Labor Standards, Reporting & Prevailing Wage Rate Determination .....	1

**TECHNICAL SPECIFICATIONS**

**DIVISION 1 - GENERAL REQUIREMENTS**

01010	Summary of Work .....	4
01300	Contractor Submittals .....	8
01505	Mobilization .....	1
01520	Security .....	1
01530	Protection and Restoration of Existing Facilities .....	5
01550	Site Access and Storage .....	4
01600	Materials and Equipment .....	2
01700	Project Closeout .....	1
01704	Final Clean-up and Site Restoration .....	1

**LIST OF DRAWINGS**

Wrangell Airport Airfield Lighting Project, Designed by RESPEC, Dated June 27, 2022

- Sheet E1.0 Legend, Single Line Diagram
- Sheet E1.1 Plan View, Airfield Lighting Shelter

**END OF SECTION**

## SECTION 00030 - NOTICE INVITING BIDS

**OBTAINING CONTRACT DOCUMENTS.** The Contract Documents are entitled:

### **WRANGELL AIRPORT AIRFIELD LIGHTING BACK-UP POWER CONNECTION**

Notice is hereby given that the City and Borough of Wrangell, Alaska will receive sealed bids for the construction of Wrangell Airport Airfield Lighting Back-Up Power Connection.

The Contract Documents may be downloaded free of charge on the City & Borough of Wrangell website ([www.wrangell.com](http://www.wrangell.com)) under the Bids and RFPs section. Downloading Contract Documents from the City & Borough of Wrangell's website requires registration with the Borough Clerk to be placed on the Plan Holders List and to ensure receipt of subsequent Addenda. Failure to register may adversely affect your proposal. It is the Offeror's responsibility to ensure that they have received all Addenda affecting this Solicitation. To be registered, email the Borough Clerk at [clerk@wrangell.com](mailto:clerk@wrangell.com).

**DESCRIPTION OF WORK.** The WORK generally includes mobilization, electrical service equipment, underground electrical systems, cabling, wiring, panelboard, and other improvements necessary to provide for a backup power generator connection. The Engineer's Estimate for all work is approximately \$25,000.

**SITE OF WORK.** The WORK is located at the Wrangell Airport, Airport Loop Road, in Wrangell, Alaska.

**COMPLETION OF WORK.** The OWNER will open the work site to the CONTRACTOR immediately following the Notice to Proceed. Substantial completion must be reached by September 30, 2024.

**BIDDING, CONTRACT, or TECHNICAL QUESTIONS.** All communications relative to this WORK, prior to opening Bids, shall be directed to the following:

Amber Al-Haddad  
Capital Facilities Director  
Telephone: (907) 874-2381  
Email: [aal-haddad@wrangell.com](mailto:aal-haddad@wrangell.com)

**BID SECURITY.** Each bid shall be accompanied by a bid bond, cashier's check or certified check made payable to the City and Borough of Wrangell in the amount of five percent (5%) of the total bid price. This serves as a guarantee that the Bidder, if its Bid is accepted, will promptly execute the Agreement. A Bid shall not be considered unless one of the forms of Bidder's security is enclosed with it.

**PREBID CONFERENCE.** A prebid conference for all bidders will be held at the Airport project site on April 24th, 2024 at 11:30AM, local time to review project scope and site access. Prospective bidders are encouraged to attend.

**RECEIPT OF BIDS.** Sealed bids will be received by the City and Borough of Wrangell, Post Office Box 531, Wrangell, Alaska 99929, located at the Borough Clerk's Office, 205 Brueger Street, Wrangell, Alaska 99929, until 2:00 PM prevailing time on **May 1, 2024**, at which time they shall be opened and read aloud. Opening date and time may be changed to a later date or time via Addendum. Clearly mark on the outside of the envelope "**Sealed Bid for WRANGELL AIRPORT AIRFIELD LIGHTING BACK-UP POWER CONNECTION**".

**SUBCONTRACTORS.** The apparent low Bidder is required to complete and submit the following documentation within five (5) calendar days following the posting of bids by the City and Borough of Wrangell:

- Section 00360 - Subcontractor Report.

**SECTION 00030 - NOTICE INVITING BIDS**

**CONTRACTOR'S LICENSE.** All contractors are required to have a current Alaska Contractor's License, prior to submitting a Bid, and a current Alaska Business License prior to award of the bid.

**BID TO REMAIN OPEN.** The Bidder shall guarantee the Bid for a period of 60 Days from the date of Bid opening. Any component of the Bid including additive alternates may be awarded anytime during the 60 Days.

**OWNER'S RIGHTS RESERVED.** The OWNER reserves the right to reject any or all Bids, to waive any informality in a Bid, and to make award to the lowest responsive, responsible Bidder as it may best serve the interests of the OWNER.

**OWNER: The City and Borough of Wrangell**

By: \_\_\_\_\_  
Mason Villarma, Interim Borough Manager

\_\_\_\_\_  
Date

**END OF SECTION**

## SECTION 00100 - INSTRUCTIONS TO BIDDERS

**1.0 DEFINED TERMS.** Terms used in these “Instructions to Bidders” and the “Notice Inviting Bids” which are defined in the General Conditions have the meanings assigned to them in the General Conditions. The term “Bidder” means one who submits a Bid directly to the OWNER, as distinct from a sub-bidder, who submits a Bid to a Bidder.

### **2.0 INTERPRETATIONS AND ADDENDA.**

A. **INTERPRETATIONS.** All questions about the meaning or intent of the Contract Documents are to be directed to the ENGINEER. Interpretations or clarifications considered necessary by the ENGINEER in response to such questions will be issued by Addendum and emailed to all parties recorded by the OWNER as having received the Contract Documents. Questions received less than 7 Days prior to the date for opening of Bids may not be answered. Only questions answered by formal written Addendum will be binding. Oral and other interpretations or clarifications will be without legal effect.

B. **ADDENDA.** Addenda may be issued to modify the Contract Documents as deemed advisable by the OWNER. The OWNER may issue addenda by fax, with a follow-up addendum copy issued by regular mail. Addenda may be emailed less than 7 Days prior to the anticipated Bid opening. The OWNER will make reasonable attempts to provide addenda; however, it is strongly recommended by the OWNER that Bidders independently confirm the contents, number, and dates of each Addenda prior to submitting a Bid. All Bidders who submit a bid shall be deemed to have received and reviewed all addenda.

**3.0 FAIR COMPETITION.** More than one Bid from an individual, firm, partnership, corporation, or association under the same or different names will not be considered. If the OWNER believes that any Bidder is interested in more than one Bid for the WORK contemplated, all Bids in which such Bidder is interested will be rejected. If the OWNER believes that collusion exists among the Bidders, all Bids will be rejected.

**4.0 RESPONSIBLE BIDDER.** Only responsive Bids from responsible Bidders will be considered. A Bid submitted by a Bidder determined to be not responsible may be rejected. A responsible Bidder is one who is considered to be capable of performing the WORK.

A. The general standards for responsibility are to determine the CONTRACTOR’s ability to perform WORK adequately, considering the CONTRACTOR’s

1. Financial Resources
2. Ability to Meet Delivery Standards
3. Past Performance Record
  - a. References from others on CONTRACTOR’s performance
  - b. Record of performance on prior OWNER contracts
4. Record of Integrity
5. Obligations to OWNER
  - a. Bidders must be registered as required by law and in good standing for all amounts owed to the OWNER within 5 Days of OWNER’s Notice of Intent to Award.

## SECTION 00100 - INSTRUCTIONS TO BIDDERS

- B. Special standards for responsibility, if applicable, will be specified. These special standards establish minimum standards or experience required for a responsible Bidder on a specific contract.
- C. Before a Bid is considered for award, a Bidder may be requested to submit information documenting its ability and competency to perform the WORK, according to general standards of responsibility and any special standards which may apply. It is Bidder's responsibility to submit sufficient, relevant, and adequate information. OWNER will make its determination of responsibility and has no obligation to request clarification or supplementary information.

**5.0 RESPONSIVE BIDS.** Only responsive Bids will be considered. Bids may be considered non-responsive and may be rejected. Some of the reasons a Bid may be rejected for being non-responsive are:

- A. If the Bid is on a form other than that furnished by the OWNER, or legible copies thereof; or if the form is altered or any part thereof is detached; or if the Bid is improperly signed.
- B. If there are unauthorized additions, conditional or alternate bids, or irregularities of any kind which may tend to make the proposal incomplete, indefinite, or ambiguous as to its meaning.
- C. If the Bidder adds any unauthorized conditions, limitations, or provisions reserving the right to accept or reject any award, or to enter into a contract pursuant to an award. This does not exclude a Bid limiting the maximum gross amount of awards acceptable to any one Bidder at any one bid opening, provided that any selection of awards will be made by the OWNER.
- D. If the Bid does not contain a unit price for each pay item listed, except in the case of authorized alternate pay items.
- E. If the Bidder has not acknowledged receipt of each Addendum.
- F. If the Bidder fails to furnish an acceptable Bid Guaranty with the Bid.
- G. If any of the unit prices bid are excessively unbalanced (either above or below the amount of a reasonable Bid) to the potential detriment of the OWNER.
- H. If a bid does not conform to Articles 15.0 and 16.0 of this Section.

**6.0 BIDDER'S EXAMINATION OF CONTRACT DOCUMENTS AND SITE.** It is the responsibility of each Bidder before submitting a Bid:

- A. To examine thoroughly the Contract Documents, and other related data identified in the bidding documents (including "technical data" referred to below):
  - 1. To visit the site to become familiar with and to satisfy the Bidder as to the general and local conditions that may affect cost, progress, or performance of the WORK;
  - 2. To consider federal, state and local laws and regulations that may affect cost, progress, or performance of the WORK;

## SECTION 00100 - INSTRUCTIONS TO BIDDERS

3. To study and carefully correlate the Bidder's observations with the Contract Documents, and other related data; and
4. To notify the ENGINEER of all conflicts, errors, or discrepancies in or between the Contract Documents and such other related data.

### 7.0 REFERENCE IS MADE TO THE SUPPLEMENTARY GENERAL CONDITIONS FOR IDENTIFICATION OF:

- A. Those reports of explorations and tests of subsurface conditions at the site which have been utilized by the Engineer of Record in the preparation of the Contract Documents. The Bidder may rely upon the accuracy of the technical data contained in such reports; however, the interpretation of such technical data is the responsibility of the Bidder.
- B. Those drawings of physical conditions in or relating to existing surface and subsurface conditions (except underground utilities) which are at, or contiguous to, the site have been utilized by the Engineer of Record in the preparation of the Contract Documents. The Bidder may rely upon the accuracy of the technical data contained in such drawings; however, the interpretation of such technical data is the responsibility of the Bidder.
- C. Copies of such reports and drawings will be made available by the OWNER to any Bidder on request if said reports and drawings are not bound herein. Those reports and drawings are not part of the Contract Documents, but the technical data contained therein upon which the Bidder is entitled to rely, as provided in Paragraph SGC-4.2 of the Supplementary General Conditions, are incorporated herein by reference.
- D. Information and data reflected in the Contract Documents with respect to underground utilities at or contiguous to the site is based upon information and data furnished to the OWNER and the Engineer of Record by the owners of such underground utilities or others, and the OWNER and ENGINEER do not assume responsibility for the accuracy or completeness thereof unless it is expressly provided otherwise in the Supplementary General Conditions, or in Section 01530 - Protection and Restoration of Existing Facilities.
- E. Provisions concerning responsibilities for the adequacy of data furnished to prospective Bidders on subsurface conditions, underground utilities and other physical conditions, and possible changes in the Contract Documents due to differing conditions appear in Paragraphs 4.2, 4.3, and 4.4 of the General Conditions.
- F. Before submitting a Bid, each Bidder will, at its own expense, make or obtain any additional examinations, investigations, explorations, tests, and studies and obtain any additional information and data which pertain to the physical conditions (surface, subsurface, and underground utilities) at, or contiguous to, the site or otherwise which may affect cost, progress, or performance of the WORK and which the Bidder deems necessary to determine its Bid for performing the WORK in accordance with the time, price, and other terms and conditions of the Contract Documents.
- G. On request in advance, the OWNER will provide each Bidder access to the site to conduct such explorations and tests as each Bidder deems necessary for submission of a Bid. Bidder shall fill all holes and shall clean up and restore the site to its former condition upon completion of such explorations.

## SECTION 00100 - INSTRUCTIONS TO BIDDERS

- H. The lands upon which the WORK is to be performed, rights-of-way and easements for access thereto and the lands designated for use by the CONTRACTOR in performing the WORK are identified in the Contract Documents. All additional lands and access thereto required for temporary construction facilities or storage of materials and equipment are to be provided by the CONTRACTOR. Easements for permanent structures or permanent changes in existing structures are to be obtained and paid for by the OWNER unless otherwise provided in the Contract Documents.
- I. The submission of a Bid will constitute an incontrovertible representation by the Bidder that the Bidder has complied with every requirement of Article 6, "Bidder's Examination of Contract Documents and Site" herein, that without exception the Bid is premised upon performing the WORK required by the Contract Documents and such means, methods, techniques, sequences, or procedures of construction as may be indicated in or required by the Contract Documents, and that the Contract Documents are sufficient in scope and detail to indicate and convey understanding of all terms and conditions for performance of the WORK.

### 8.0 BID FORM.

- A. The Bid shall be made on the Bid Schedule(s) bound herein, or on legible and complete copies thereof, and shall contain the following: Sections 00300 - Bid, 00310 - Bid Schedule, and the required Bid Security. In the event there is more than one Bid Schedule, the Bidder may bid on any individual schedule or on any combination of schedules. The envelope enclosing the sealed Bids shall be plainly marked in the upper left-hand corner with the name and address of the Bidder and shall bear the words "BID FOR," followed by the title of the Contract Documents for the WORK, the name of the OWNER, the address where Bids are to be delivered or mailed to, and the date and hour of opening of Bids. The Bid Security shall be enclosed in the same envelope with the Bid.
- B. All blanks on the Bid Form and Bid Schedule(s) must be completed in ink or typed.
- C. Bids by corporations shall be executed in the corporate name by the president, a vice-president (or another corporate officer). The corporate address and state of incorporation must appear below the signature.
- D. Bids by partnerships must be executed in the partnership name and be signed by a managing partner, and the official address of the partnership must appear below the signature.
- E. The Bidder's Bid shall be signed with ink. All names must be printed or typed below the signature.
- F. The Bid shall contain an acknowledgment of receipt of all Addenda, the numbers of which must be filled in on the Bid Form. Failure to acknowledge Addenda shall render Bid non-responsive and shall cause its rejection.
- G. The address to which communications regarding the Bid are to be directed must be shown.
- H. All Bidders shall provide evidence of authority to conduct business in Alaska to the extent required by law.



## SECTION 00100 - INSTRUCTIONS TO BIDDERS

- I. On Projects including Federal funding, any contractor otherwise qualified to perform the WORK is not required to be licensed nor to submit application for license in advance of submitting a Bid or having such Bid considered; provided, however, that such exemption does not constitute a waiver of the OWNER's right under existing license laws to require a contractor, determined to be a successful Bidder, to be licensed to do business as a contractor in the State of Alaska in connection with the award of a contract to the successful Bidder.
- J. A Bid for the WORK will not be accepted from a contractor who does not hold a valid Alaska Business License and a valid Contractor's License in Alaska (applicable to the type of work bid upon) at the time of opening Bids.

**9.0 BID ALTERNATES.** The project contains the following alternates:

- A. Not used.

**10.0 QUANTITIES OF WORK.** The quantities of WORK, or material, stated in unit price items of the Bid are supplied only to give an indication of the general scope of the WORK; the OWNER does not expressly or by implication agree that the actual amount of WORK, or material, will correspond therewith, and reserves the right after award to increase or decrease the amount of any unit price item of the WORK by an amount up to and including 25 percent of any Bid item, without a change in the unit price, and shall include the right to delete any Bid item in its entirety, or to add additional Bid items up to and including an aggregate total amount not to exceed 25 percent of the Contract Price (see General Conditions, Article 10 Changes In the Work).

**11.0 SUBSTITUTE OR "OR-EQUAL" ITEMS.** The procedure for the submittal of substitute or "or-equal" products is specified in Section 01300 - Contractor Submittals.

**12.0 SUBMISSION OF BIDS.** The Bid shall be delivered by the time and to the place stipulated in the Notice Inviting Bids. It is the Bidder's sole responsibility to see that its Bid is received in proper time. Oral, telegraphic, telephonic or faxed Bids will not be considered.

**13.0 BID SECURITY, BONDS, AND INSURANCE.** Each Bid shall be accompanied by a certified, or cashier's check, or approved Bid Bond in an amount of at least 5 percent of the total Bid price. The "total Bid price" is the amount of the base bid, plus the amount of alternate bids, if any, which total to the maximum amount for which the contract could be awarded. Said check or Bond shall be made payable to the OWNER and shall be given as a guarantee that the Bidder, if offered the WORK, will enter into an Agreement with the OWNER, and will furnish the necessary insurance certificates, Payment Bond, and Performance Bond; each of said Bonds, if required, and insurance amounts shall be as stated in the Supplementary General Conditions. In case of refusal or failure to enter into said Agreement, the check or Bid Bond, as the case may be, shall be forfeited to the OWNER. If the Bidder elects to furnish a Bid Bond as its Bid security, the Bidder shall use the Bid Bond form bound herein, or one conforming substantially to it in form. Bid Bonds must be accompanied by a legible power of attorney.

**14.0 RETURN OF BID SECURITY.** Within 14 Days after award of the contract, the OWNER will return the Bid securities accompanying such of the Bids as are not considered in making the award. All other Bid securities will be held until the Agreement has been executed. They will then be returned to the respective Bidders whose Bids they accompanied.

## SECTION 00100 - INSTRUCTIONS TO BIDDERS

**15.0 DISCREPANCIES IN BIDS.** In the event there is more than one pay item in a Bid Schedule, the Bidder shall furnish a price for all pay items in the schedule, and failure to do so may render the Bid non-responsive and cause its rejection. In the event there are unit price pay items in a Bid Schedule and the “amount” indicated for a unit price pay item does not equal the product of the unit price and quantity, the unit price shall govern and the amount will be corrected accordingly, and the Bidder shall be bound by said correction. In the event there is more than one pay item in the Bid Schedule and the total indicated for the schedule does not agree with the sum of the prices bid on the individual items, the prices bid on the individual items shall govern and the total for the schedule will be corrected accordingly, and the Bidder shall be bound by the correction.

### **16.0 BID MODIFICATIONS AND UNAUTHORIZED ALTERNATIVE BIDS.**

A. Any Bidder may modify a Bid by mail, email ([clerk@wrangell.com](mailto:clerk@wrangell.com)), or fax (**Fax: 907-874-3952**) provided that such modification is received by the OWNER prior to the time set for opening of Bids. Bid modifications shall be made using the project Modified Bid Schedule form and shall be used with bid modifications made as a line by line pay item adjustment per the schedule. Bidders are strongly advised to telephone the City & Borough of Wrangell (**Telephone: 907-874-2381**) to confirm the successful and timely transmission of all email and fax Bid modifications.

An email or fax Bid Modification shall not reveal the Bid price but shall provide the addition or subtraction or other modification so that the final prices will not be known by the OWNER until the sealed Bid is opened. Modifications shall include both the modification of the unit bid price and the total modification of each item modified. The OWNER shall not be responsible for its failure to receive fax modifications whether such failure is caused by transmission line problems, fax device problems, operator error or otherwise.

B. Unauthorized conditions, limitations, or provisions attached to the Bid will render it informal and cause its rejection as being non-responsive. The completed bid forms shall be without interlineation, alterations, or erasures in the printed text. All changes shall be initialed by the person signing the Bid. Alternative bids will not be considered unless called for.

**17.0 WITHDRAWAL OF BID.** The Bid may be withdrawn by the Bidder by means of a written request, signed by the Bidder or its properly authorized representative. Such written request must be delivered to the place stipulated in the Notice Inviting Bids for receipt of Bids prior to the scheduled closing time for receipt of Bids.

### **18.0 AWARD OF CONTRACT.**

A. Award of a contract, if it is awarded, will be on the basis of materials and equipment described in the Drawings or specified in the Technical Specifications and will be made to the lowest responsive, responsible Bidder whose Bid complies with all the requirements prescribed. Unless otherwise specified, any such award will be made within the period stated in the Notice Inviting Bids that the Bids are to remain open. Unless otherwise indicated, a single award will be made for all the pay items in an individual Bid Schedule.

B. If the OWNER has elected to advertise this Project with a base bid and additive or deductive alternates, the OWNER may elect to award the contract for the base bid, or the

## SECTION 00100 - INSTRUCTIONS TO BIDDERS

base bid plus one or more alternates selected by the OWNER. In either case, award shall be made to the responsive, responsible Bidder offering the lowest total bid for the WORK to be awarded.

- C. Low Bidder will be determined based on the lowest total of the base bid plus combinations of additive alternatives as deemed in the best interest of the OWNER.
- D. A Local Bidder Preference shall apply to all City and Borough of Wrangell procurements, except when restricted by state or federal regulations. To be considered a qualifying bidder, bidders shall meet the requirements of the Local Bidder Preference ordinance, according to WMC 5.10.040 (D). The Owner may request documentation to support entries made on this form.

The Wrangell Municipal Code (WMC) Article 5.10.040, Section D. LOCAL BIDDER PREFERENCE AWARD reads:

1. Unless contrary to federal or state law or regulation, or as otherwise provided in section (D)(2) of this section, a contract for, or purchase of, supplies, materials, equipment, contractual services, or public improvements shall be awarded to a local bidder where the bid by such local bidder is in all material respects comparable to the lowest responsible nonlocal bid, and if the amount bid by such local bidder does not exceed the lowest responsible nonlocal bid by more than:
  - a. Five percent of the amount bid by the lowest responsible nonlocal bidder if that nonlocal bidder's bid is \$1,000,000 or less;
  - b. Three percent of the amount bid by the lowest responsible nonlocal bidder if that nonlocal bidder's bid is \$1,000,001 or more.
2. This preference shall not be interpreted to mean that the borough is precluded from making the purchase from whatever source is most advantageous to the borough after considering all factors in the public interest even when the price quoted by the local bidder satisfies subsection (D)(1)(a) or (b) of this section.
3. "Local bidder" for purposes of the section shall mean a bidder who:
  - a. Holds a current Alaska business license;
  - b. Submits a bid for goods or services under the name appearing on the person's current Alaska business license;
  - c. Has maintained a place of business within the boundaries of the borough for a period of six months immediately preceding the date of the bid;
  - d. Is not delinquent in the payment of any utilities, taxes, charges or assessments owing to the borough on account of that business;

## SECTION 00100 - INSTRUCTIONS TO BIDDERS

- e. Is incorporated or qualified to do business under the laws of Alaska with its principal place of business in the borough, is a proprietorship and the proprietor is a resident of the borough, or is a partnership and all partners are residents of the City and Borough of Wrangell;
- f. If a joint venture, all joint venture partners must qualify under subsection (D)(3)(a) through (e) of this section;
- g. The manager may require such documentation or verification by the person claiming to be a local bidder as is deemed necessary to establish the requirements of this section.

### 19.0 EXECUTION OF AGREEMENT.

- A. All Bids must be approved by the Wrangell Borough Assembly. After the Assembly has approved the award, the OWNER will issue a Notice of Intent to Award to the approved Bidder following the Bid Opening. The Bidder to whom award is made shall execute a written Agreement with the OWNER on the Agreement form, Section 00500, and shall secure all insurance and furnish all certificates and bonds required by the Contract Documents within 10 Days from the date stated in the Notice of Intent to Award letter.
- B. Failure or refusal to enter into the Agreement as herein provided or to conform to any of the stipulated requirements in connection therewith shall be just cause for annulment of the award and forfeiture of the Bid security. If the lowest responsive, responsible Bidder refuses or fails to execute the Agreement, the OWNER may award the contract to the second lowest responsive, responsible Bidder. If the second lowest responsive, responsible Bidder refuses or fails to execute the Agreement, the OWNER may award the contract to the third lowest responsive, responsible Bidder. On the failure or refusal of such second or third lowest Bidder to execute the Agreement, each such Bidder's Bid securities shall be likewise forfeited to the OWNER.

**20.0 LIQUIDATED DAMAGES.** Provisions for liquidated damages are set forth in the Agreement.

**21.0 PERMITS.** The CONTRACTOR is responsible for all WORK associated with meeting any local, state, and federal permit requirements.

**END OF SECTION**



CITY AND BOROUGH OF WRANGELL

**LOCAL BIDDER PREFERENCE AFFIDAVIT**

In response to the Invitation to Bid for:

Project Name: \_\_\_\_\_

I certify under penalty of perjury that (Bidder Name)

\_\_\_\_\_ qualifies for the City and Borough of Wrangell's Local Bidder's Preference under the following conditions:

- A. If a bidder qualifies under WMC 5.10.040 (D) as a Local Bidder and is a qualifying entity, a five percent (5%) bid preference shall be applied to the bid price for the purpose of award. In this subsection, a "qualifying entity" means a local bidder who:
1. Holds a current Alaska business license;
  2. Submits a bid for goods or services under the name appearing on the person's current Alaska business license;
  3. Has maintained a place of business within the boundaries of the borough for a period of six months immediately preceding the date of the bid;
  4. Is not delinquent in the payment of any utilities, taxes, charges or assessments owing to the borough on account of that business;
  5. Is incorporated or qualified to do business under the laws of Alaska with its principal place of business in the borough, is a proprietorship and the proprietor is a resident of the borough, or is a partnership and all partners are residents of the City and Borough of Wrangell;
  6. If a joint venture, all joint venture partners must qualify under subsection (D)(3)(a) through (e) of this section.

The Owner may request documentation to support entries made on this form.

\_\_\_\_\_  
Authorized Signature

\_\_\_\_\_  
Printed Name

\_\_\_\_\_  
Date

**SECTION 00310 - BID SCHEDULE**

Bidders Please Note: Before preparing this Bid Schedule, carefully read the Invitation for Bids, Instructions to Bidders, and the Technical Specifications.

The Bidder shall insert a unit price opposite each pay item in the Bid Schedule and multiply the unit price by the estimated quantities for this contract. No price is to be tendered for any item not appearing in the Bid Schedule.

In the event there is more than one pay item in the Bid Schedule and the total indicated for the schedule does not agree with the sum of the prices bid on the individual items, the prices bid on the individual items shall govern and the total for the schedule will be corrected accordingly, and the Bidder shall be bound by the correction.

A Local Bidder Preference of five percent (5%)   X   will, \_\_\_\_\_ will not be utilized on this project.

**WRANGELL AIRPORT AIRFIELD LIGHTING BACK-UP POWER CONNECTION - BASE BID**

Pay Item No.	Pay Item Description	Pay Unit	Approximate Quantity	Unit Price		Amount	
				Dollars	Cents	Dollars	Cents
1	Mobilization	LS	All Req'd				
2	Electrical Systems	LS	All Req'd				

**TOTAL WRANGELL AIRPORT AIRFIELD LIGHTING BACK-UP POWER CONNECTION BASE BID AMOUNT IN FIGURES: \$** \_\_\_\_\_

**TOTAL WRANGELL AIRPORT AIRFIELD LIGHTING BACK-UP POWER CONNECTION BASE BID AMOUNT IN WORDS:**  
 \_\_\_\_\_

**BIDDER NAME:** \_\_\_\_\_

**BIDDER'S TELEPHONE:** \_\_\_\_\_

**BIDDER'S EMAIL:** \_\_\_\_\_

**END OF SECTION**

**SECTION 00320 - BID BOND**

KNOW ALL PERSONS BY THESE PRESENTS, that \_\_\_\_\_

\_\_\_\_\_ as Principal, and \_\_\_\_\_

as Surety, are held and firmly bound unto the **CITY & BOROUGH OF WRANGELL** hereinafter called "OWNER," in the sum of \_\_\_\_\_ dollars, (not less than five percent (5%) of the total amount of the Bid) for the payment of which sum, well and truly to be made, we bind ourselves, our heirs, executors, administrators, successors, and assigns, jointly and severally, firmly by these presents.

WHEREAS, said Principal has submitted a Bid to said OWNER to perform the WORK required under the Bid Schedule of the OWNER's Contract Documents entitled

**WRANGELL AIRPORT AIRFIELD LIGHTING BACK-UP POWER CONNECTION**

NOW THEREFORE, if said Principal is awarded a contract by said OWNER and, within the time and in the manner required in the "Notice Inviting Bids" and the "Instructions to Bidders" enters into a written Agreement on the form of Agreement bound with said Contract Documents, furnishes the required certificates of insurance, and furnishes the required Performance Bond and Payment Bond, then this obligation shall be null and void, otherwise it shall remain in full force and effect. In the event suit is brought upon this bond by said OWNER and OWNER prevails, said Surety shall pay all costs incurred by said OWNER in such suit, including a reasonable attorney's fee to be fixed by the court.

SIGNED AND SEALED, this \_\_\_\_\_ day of \_\_\_\_\_, 20\_\_

(SEAL) \_\_\_\_\_  
(Principal)

(SEAL) \_\_\_\_\_  
(Surety)

By: \_\_\_\_\_  
(Signature)

By: \_\_\_\_\_  
(Signature)

**END OF SECTION**

**SECTION 003600 - SUBCONTRACTOR REPORT**

**LIST OF SUBCONTRACTORS**

The apparent low Bidder must submit a list of Subcontractors that the Bidder proposes to use in the performance of this contract by close of business on the fifth calendar day following the posting of the bid tabulations. If the fifth calendar day falls on a weekend or holiday, the report is due by close of business on the next business day following the weekend or holiday. The list must include each Subcontractor's name, address, location, evidence of valid Alaska Business License, and valid Alaska Contractor's Registration under AS 08.18. *If no Subcontractors are to be utilized in the performance of the WORK, write in ink or type "NONE" on line (1) below.*

<u>SUBCONTRACTOR</u>	<sup>1</sup> AK Contractor License No.	<sup>1</sup> Contact Name	Type of	Contract	✓ if
<u>ADDRESS</u>	<sup>2</sup> AK Business License No.	<sup>2</sup> Phone No.	<u>Work</u>	<u>Amount</u>	<u>DBE</u>
1. _____ _____ _____	1 _____ 2 _____	_____ _____	_____ _____	\$ _____	<input type="checkbox"/>
2. _____ _____ _____	1 _____ 2 _____	_____ _____	_____ _____	\$ _____	<input type="checkbox"/>
3. _____ _____ _____	1 _____ 2 _____	_____ _____	_____ _____	\$ _____	<input type="checkbox"/>
4. _____ _____ _____	1 _____ 2 _____	_____ _____	_____ _____	\$ _____	<input type="checkbox"/>

I certify that the above listed Alaska Business License(s) and CONTRACTOR Registration(s), if applicable, were valid at the time Bids were opened for this Project.

\_\_\_\_\_  
CONTRACTOR, Authorized Signature

\_\_\_\_\_  
CONTRACTOR, Printed Name



## SECTION 003600 - SUBCONTRACTOR REPORT

- A. A Bidder may replace a listed Subcontractor if the Subcontractor:
1. fails to comply with AS 08.18;
  2. files for bankruptcy or becomes insolvent;
  3. fails to execute a contract with the Bidder involving performance of the WORK for which the Subcontractor was listed and the Bidder acted in good faith;
  4. fails to obtain bonding;
  5. fails to obtain insurance acceptable to the OWNER;
  6. fails to perform the contract with the Bidder involving work for which the Subcontractor was listed;
  7. must be substituted in order for the CONTRACTOR to satisfy required state and federal affirmative action requirements;
  8. refuses to agree or abide with the Bidder's labor agreement; or
  9. is determined by the OWNER not to be a responsible Bidder.
- B. If a Bidder fails to list a Subcontractor or lists more than one Subcontractor for the same portion of WORK, the Bidder shall be considered to have agreed to perform that portion of WORK without the use of a Subcontractor and to have represented the Bidder to be qualified to perform that WORK.
- C. A Bidder who attempts to circumvent the requirements of this section by listing as a Subcontractor another contractor who, in turn, sublets the majority of the WORK required under the contract violates this section.
- D. If a contract is awarded to a Bidder who violates this section, the OWNER may:
1. cancel the contract; or
  2. after notice and a hearing, assess a penalty on the Bidder in an amount that does not exceed 10 percent of the value of the subcontract at issue.
- E. For contract award, the apparent low Bidder must submit one copy of each subcontract, to the OWNER, for WORK with a value of greater than one half of one percent of the intended award amount.
- F. An apparent low Bidder who fails to submit a completed Subcontractor Report within the time specified in this section will be found to be not a responsible Bidder and may be required to forfeit the Bid security. The OWNER will then consider the next lowest Bidder for award of the contract.

**END OF SECTION**

**SECTION 00500 - AGREEMENT**

THIS AGREEMENT is between THE CITY & BOROUGH OF WRANGELL (hereinafter called OWNER) and \_\_\_\_\_ (hereinafter called CONTRACTOR) OWNER and CONTRACTOR, in consideration of the mutual covenants hereinafter set forth, agree as follows:

**ARTICLE 1. WORK.**

- A. CONTRACTOR shall complete the WORK as specified or as indicated under the Bid Schedule of the OWNER's Contract Documents entitled **WRANGELL AIRPORT AIRFIELD LIGHTING BACK-UP POWER CONNECTION**. The WORK is generally described as follows: WORK consists of various quantities of mobilization, electrical service equipment, underground electrical systems, cabling, wiring, panelboard, and other improvements necessary to provide for a backup power generator connection.
- B. Alternates (if applicable).

**ARTICLE 2. CONTRACT COMPLETION TIME.**

Substantial completion by \_\_\_\_\_.

**ARTICLE 3. DATE OF AGREEMENT**

The date of this Agreement will be the later of the date of the Borough Manager signature on page three of this section and the signature of the CONTRACTOR authorized representative.

**ARTICLE 4. LIQUIDATED DAMAGES.**

OWNER and the CONTRACTOR recognize that time is of the essence of this Agreement and that the OWNER will suffer financial loss if the WORK is not completed within the time specified in Article 2 herein, plus any extensions thereof allowed in accordance with Article 12 of the General Conditions. They also recognize the delays, expense, and difficulties involved in proving in a legal proceeding the actual damages suffered by the OWNER if the WORK is not completed on time. Accordingly, instead of requiring any such proof, the OWNER and the CONTRACTOR agree that as liquidated damages for delay (but not as a penalty) the CONTRACTOR shall pay the OWNER \$1,000 for each Calendar Day that expires after the substantial completion time specified in Article 2 above. The amount of liquidated damages specified above is agreed to be a reasonable estimate based on all facts known as of the date of this Agreement.

**ARTICLE 5. CONTRACT PRICE.**

OWNER shall pay CONTRACTOR for completion of the WORK in accordance with the Contract Documents in the amount set forth in the Bid Schedule. The CONTRACTOR agrees to accept as full and complete payment for all WORK to be done in this contract for: \_\_\_\_\_ those Unit Price amounts as set forth in the Bid Schedule in the Contract Documents for this Project.

The total amount of this contract shall be \_\_\_\_\_, except as adjusted in accordance with the provisions of the Contract Documents.

**ARTICLE 6. PAYMENT PROCEDURES.**

## **SECTION 00500 - AGREEMENT**

CONTRACTOR shall submit Applications for Payment in accordance with Article 14 of the General Conditions. Applications for Payment will be processed by the ENGINEER as provided in the General Conditions.

Progress payments will be paid in full in accordance with Article 14 of the General Conditions until ninety (90) percent of the Contract Price has been paid. The remaining ten (10) percent of the Contract Price may be retained, in accordance with applicable Alaska State Statutes, until final inspection, completion, and acceptance of the Project by the OWNER.

### **ARTICLE 7. CONTRACT DOCUMENTS.**

The Contract Documents which comprise the entire Agreement between OWNER and CONTRACTOR concerning the WORK consist of this Agreement (pages 00500-1 to 00500-6, inclusive) and the following sections of the Contract Documents:

- Table of Contents
- Notice Inviting Bids
- Instructions to Bidders
- Bid
- Bid Schedule
- Bid Bond
- Subcontractor Report
- Performance Bond
- Payment Bond
- Insurance Certificate(s)
- General Conditions
- Supplementary General Conditions
- Alaska Labor Standards, Reporting, and Prevailing Wage Determination
- Permits
- Technical Specifications as listed in the Table of Contents
- \_\_\_\_\_ Drawings consisting of \_\_\_\_ sheets, as listed in the Table of Contents
- Addenda numbers \_\_\_\_ to \_\_\_\_, inclusive.
- Change Orders which may be delivered or issued after the Date of the Agreement and which are not attached hereto

There are no Contract Documents other than those listed in this Article 7. The Contract Documents may only be amended by Change Order as provided in Paragraph 3.3 of the General Conditions.

### **ARTICLE 8. MISCELLANEOUS.**

Terms used in this Agreement, which are defined in Article 1 of the General Conditions, will have the meanings indicated in the General Conditions.

No assignment by a party hereto of any rights under or interests in the Contract Documents will be binding on another party hereto without the written consent of the party sought to be bound; and specifically but without limitation monies that may become due and monies that are due may not be assigned without such written consent (except to the extent that the effect of this restriction may be limited by law), and unless specifically stated to the contrary in any written consent to an assignment, no assignment will release or discharge the assignor from any duty or responsibility under the Contract Documents. CONTRACTOR understands and agrees that the Borough will not accept any assignment of this Contract to an LLC unless all the members of the LLC sign as guarantors of performance of this

**SECTION 00500 - AGREEMENT**

Contract.

OWNER and CONTRACTOR each binds itself, its partners, successors, assigns and legal representatives to the other party hereto, its partners, successors, assigns and legal representatives in respect of all covenants, agreements and obligations contained in the Contract Documents. This Agreement shall be governed by the laws of the State of Alaska. The Superior Court for the State of Alaska, First Judicial District at Wrangell, Alaska, shall be the exclusive jurisdiction and venue for any action of any kind an any nature arising out of or relating to this Agreement and all Contract documents or for any action of any kind and any nature arising out of or related to the performance of non-performance of the CONTRACTOR, and CONTRACTOR’S employees, subcontractors, consultants and representatives.

The CONTRACTOR acknowledges that the CONTRACTOR has read and understands the terms of this Agreement and the terms and conditions of all the Contract documents listed in this Agreement and has had the opportunity to review the Agreement with counsel of his/her choice, and is executing this Agreement of his/her own free will. CONTRACTOR acknowledges and agrees that CONTRACTOR is not relying on any representations by any Borough employee, the Mayor, an assembly member, the borough attorney, the borough manager or any consultant of the Borough in deciding to enter this Agreement and perform this project.

IN WITNESS WHEREOF, OWNER and CONTRACTOR have caused this Agreement to be executed on the date listed below by OWNER.

**OWNER:**

**CONTRACTOR:**

\_\_\_\_\_  
City & Borough of Wrangell

\_\_\_\_\_  
(Company Name)

\_\_\_\_\_  
(Signature)

\_\_\_\_\_  
(Signature)

By: Mason Villarma, Borough Manager  
(Printed Name)

By: \_\_\_\_\_  
(Printed Name, Authority or Title)

Date: \_\_\_\_\_

Date: \_\_\_\_\_

Address: P.O. Box 531

Address: \_\_\_\_\_

\_\_\_\_\_  
Wrangell, Alaska 99929

\_\_\_\_\_

907-874-2381      907-874-3952  
(Telephone)              (Fax)

\_\_\_\_\_  
(Telephone)              (Fax)

\_\_\_\_\_  
(E-mail address)

Owner Attest:

Contractor Attest:

By: \_\_\_\_\_  
Kim Lane, Borough Clerk

By: \_\_\_\_\_  
Name/Title:

SECTION 00500 - AGREEMENT

CERTIFICATE  
(if Corporation)

STATE OF )  
 ) SS:  
COUNTY OF )

I HEREBY CERTIFY that a meeting of the Board of Directors of the \_\_\_\_\_ a corporation existing under the laws of the State of \_\_\_\_\_, held on \_\_\_\_\_, 20\_\_\_\_, the following resolution was duly passed and adopted:

“RESOLVED, that \_\_\_\_\_, as \_\_\_\_\_ President of the Corporation, be and is hereby authorized to **execute the Agreement** with OWNER and this corporation and that the execution thereof, attested by the Secretary of the Corporation, and with the Corporate Seal affixed, shall be the official act and deed of this Corporation.”

I further certify that said resolution is now in full force and effect.

IN WITNESS WHEREOF, I have hereunto set my hand and affixed the official seal of the Corporation this \_\_\_\_\_ day of \_\_\_\_\_, 20\_\_\_\_\_.

\_\_\_\_\_  
Secretary

(SEAL)

SECTION 00500 - AGREEMENT

CERTIFICATE  
(if Partnership)

STATE OF )  
 ) SS:  
COUNTY OF )

I HEREBY CERTIFY that a meeting of the Partners of the \_\_\_\_\_ a partnership existing under the laws of the State of \_\_\_\_\_, held on \_\_\_\_\_, 20\_\_\_\_, the following resolution was duly passed and adopted:

"RESOLVED, that \_\_\_\_\_, as \_\_\_\_\_ of the Partnership, be and is hereby authorized to **execute the Agreement** with the OWNER and this partnership and that the execution thereof, attested by the \_\_\_\_\_ shall be the official act and deed of this Partnership."

I further certify that said resolution is now in full force and effect.

IN WITNESS WHEREOF, I have hereunto set my hand this \_\_\_\_\_, day of \_\_\_\_\_, 20\_\_\_\_\_.

\_\_\_\_\_  
Secretary

(SEAL)

SECTION 00500 - AGREEMENT

CERTIFICATE  
(if Joint Venture)

STATE OF )  
) SS:  
COUNTY OF )

I HEREBY CERTIFY that a meeting of the Principals of the

\_\_\_\_\_ a joint venture existing under the laws of the

State of \_\_\_\_\_, held on \_\_\_\_\_, 20\_\_\_\_, the following resolution was duly passed and adopted:

"RESOLVED, that \_\_\_\_\_, as \_\_\_\_\_ of the Joint Venture, be and is hereby authorized to **execute the Agreement** with the OWNER and this joint venture and that the execution thereof, attested by the \_\_\_\_\_ shall be the official act and deed of this Joint Venture."

I further certify that said resolution is now in full force and effect.

IN WITNESS WHEREOF, I have hereunto set my hand this \_\_\_\_\_, day of \_\_\_\_\_, 20\_\_\_\_.

\_\_\_\_\_  
Secretary

(SEAL)

**SECTION 00500 - AGREEMENT**

**CERTIFICATE**  
**(If Limited Liability Company)**

STATE OF            )  
                          ) SS:  
COUNTY OF    )

I HEREBY CERTIFY that a meeting of the members of the

\_\_\_\_\_, a Limited Liability Company (LLC) existing under the laws of the State of \_\_\_\_\_, held on \_\_\_\_\_, 20\_\_\_\_, the following resolution was duly passed and adopted:

"RESOLVED, that \_\_\_\_\_, acting as \_\_\_\_\_ of the Limited Liability Company, is hereby authorized by all Members to **execute the Agreement** with the OWNER and this Limited Liability Company and that the execution thereof, attested by the \_\_\_\_\_ shall be the official act and deed of this Limited liability Company."

I further certify that said resolution is now in full force and effect.

IN WITNESS WHEREOF, I have hereunto set my hand this \_\_\_\_\_, day of \_\_\_\_\_, 20\_\_\_\_\_.

\_\_\_\_\_  
Secretary

(SEAL)

By: \_\_\_\_\_  
(Signature of authorized Member)

\_\_\_\_\_  
(Title of person signing)

**END OF SECTION**



**SECTION 00700 - GENERAL CONDITIONS**

**TABLE OF CONTENTS**

**ARTICLE 1 DEFINITIONS**..... 00700-5

**ARTICLE 2 PRELIMINARY MATTERS**

2.1 Delivery of Bonds/Insurance Certificates ..... 00700-8  
2.2 Copies of Documents ..... 00700-8  
2.3 Commencement of Contract Time; Notice to Proceed ..... 00700-9  
2.4 Starting the WORK..... 00700-9  
2.5 Pre-construction Conference..... 00700-9

**ARTICLE 3 CONTRACT DOCUMENTS: INTENT, AMENDING, REUSE**

3.1 Intent ..... 00700-9  
3.2 Order of Precedence of Contract Documents..... 00700-10  
3.3 Amending and Supplementing Contract Documents ..... 00700-10  
3.4 Reuse of Documents ..... 00700-10

**ARTICLE 4 AVAILABILITY OF LANDS; PHYSICAL CONDITIONS; REFERENCE POINTS**

4.1 Availability of Lands ..... 00700-11  
4.2 Physical Conditions - Subsurface and Existing Structures ..... 00700-11  
4.3 Differing Site Conditions ..... 00700-11  
4.4 Physical Conditions - Underground Utilities ..... 00700-12  
4.5 Reference Points ..... 00700-12

**ARTICLE 5 BONDS AND INSURANCE**

5.1 Performance, Payment and Other Bonds ..... 00700-13  
5.2 Insurance ..... 00700-13

**ARTICLE 6 CONTRACTOR’S RESPONSIBILITIES**

6.1 Supervision and Superintendence ..... 00700-14  
6.2 Labor, Materials, and Equipment..... 00700-14  
6.3 Adjusting Progress Schedule..... 00700-16  
6.4 Substitutes or “Or Equal” Items..... 00700-16  
6.5 Concerning Subcontractors, Suppliers and Others..... 00700-16  
6.6 Permits ..... 00700-16  
6.7 Patent Fees and Royalties ..... 00700-17  
6.8 Laws and Regulations ..... 00700-17

**SECTION 00700 - GENERAL CONDITIONS**

**ARTICLE 6 CONTRACTOR’S RESPONSIBILITIES (Cont’d.)**

6.9 Taxes ..... 00700-17  
6.10 Use of Premises..... 00700-18  
6.11 Safety and Protection ..... 00700-18  
6.12 Shop Drawings and Samples..... 00700-19  
6.13 Continuing the WORK..... 00700-19  
6.14 Indemnification ..... 00700-19  
6.15 Contractor’s Daily Reports ..... 00700-20  
6.16 Assignment of Contract ..... 00700-20  
6.17 Contractor’s Responsibility for Utility Property and Services ..... 00700-20  
6.18 Operating Water System Valves ..... 00700-21  
6.19 CONTRACTOR’S WORK Schedule Limitations ..... 00700-21

**ARTICLE 7 OTHER WORK**

7.1 Related WORK at Site ..... 00700-21  
7.2 Coordination..... 00700-22

**ARTICLE 8 OWNER’S RESPONSIBILITIES**

8.1 Communications ..... 00700-22  
8.2 Payments ..... 00700-22  
8.3 Lands, Easements, and Surveys ..... 00700-22  
8.4 Change Orders..... 00700-22  
8.5 Inspections and Tests ..... 00700-22  
8.6 Suspension of WORK..... 00700-22  
8.7 Termination of Agreement..... 00700-22

**ARTICLE 9 ENGINEER’S STATUS DURING CONSTRUCTION**

9.1 OWNER’s Representative ..... 00700-22  
9.2 Visits to Site ..... 00700-22  
9.3 Project Representation ..... 00700-23  
9.4 Clarifications and Interpretations..... 00700-25  
9.5 Authorized Variations in WORK..... 00700-25  
9.6 Rejecting Defective WORK..... 00700-25  
9.7 CONTRACTOR Submittals, Change Orders, and Payments ..... 00700-25  
9.8 Decisions on Disputes ..... 00700-25  
9.9 Limitation on Engineer’s Responsibilities ..... 00700-26

**ARTICLE 10 CHANGES IN THE WORK**

10.1 General ..... 00700-27  
10.2 Allowable Quantity Variations ..... 00700-27

**ARTICLE 11 CHANGE OF CONTRACT PRICE**

**SECTION 00700 - GENERAL CONDITIONS**

11.1 General..... 00700-28  
11.2 Costs Relating to Weather..... 00700-28  
11.3 Cost of WORK (Based on Time and Materials) ..... 00700-29  
11.4 CONTRACTOR’S Fee ..... 00700-31  
11.5 Excluded Costs..... 00700-32

**ARTICLE 12 CHANGE OF CONTRACT TIME**

12.1 General..... 00700-33  
12.2 Extensions of Time for Delay Due to Weather..... 00700-33

**ARTICLE 13 WARRANTY AND GUARANTEE; TESTS AND INSPECTIONS, CORRECTION, REMOVAL, OR ACCEPTANCE OF DEFECTIVE WORK**

13.1 Warranty and Guarantee ..... 00700-34  
13.2 Access to WORK..... 00700-34  
13.3 Tests and Inspections ..... 00700-34  
13.4 OWNER May Stop the WORK ..... 00700-35  
13.5 Correction or Removal of Defective WORK..... 00700-35  
13.6 One Year Correction Period..... 00700-35  
13.7 Acceptance of Defective WORK..... 00700-36

**ARTICLE 14 PAYMENTS TO CONTRACTOR AND COMPLETION**

14.1 Schedule of Values (Lump Sum Price Breakdown)..... 00700-36  
14.2 Unit Price Bid Schedule..... 00700-36  
14.3 Application for Progress Payment ..... 00700-36  
14.4 CONTRACTOR’S Warranty of Title ..... 00700-37  
14.5 Review of Applications for Progress Payment ..... 00700-37  
14.6 Partial Utilization ..... 00700-38  
14.7 Substantial Completion..... 00700-38  
14.8 Final Application for Payment..... 00700-38  
14.9 Final Payment and Acceptance ..... 00700-38  
14.10 Release of Retainage and Other Deductions ..... 00700-39  
14.11 CONTRACTOR’S Continuing Obligation ..... 00700-39  
14.12 Final Payment Terminates Liability of OWNER ..... 00700-39

**ARTICLE 15 SUSPENSION OF WORK AND TERMINATION**

15.1 Suspension of WORK by OWNER ..... 00700-40  
15.2 Termination of Agreement by OWNER (CONTRACTOR Default)..... 00700-40  
15.3 Termination of Agreement by OWNER (For Convenience) ..... 00700-40  
15.4 Termination of Agreement by CONTRACTOR..... 00700-41

**ARTICLE 16 MISCELLANEOUS**

16.1 Giving Notice..... 00700-41  
16.2 Rights In and Use of Materials Found on the WORK ..... 00700-41

**SECTION 00700 - GENERAL CONDITIONS**

16.3 Right to Audit..... 00700-42  
16.4 Archaeological or Historical Discoveries ..... 00700-42  
16.5 Construction Over or Adjacent to Navigable Waters..... 00700-42  
16.6 Gratuity and Conflict of Interest ..... 00700-42  
16.7 Suits of Law Concerning the WORK..... 00700-42  
16.8 Certified Payrolls ..... 00700-43  
16.9 Prevailing Wage Rates ..... 00700-43  
16.10 Employment Reference..... 00700-44  
16.11 Cost Reduction Incentive ..... 00700-44

## SECTION 00700 - GENERAL CONDITIONS

### ARTICLE 1 DEFINITIONS

Wherever used in these General Conditions or in the other Contract Documents the following terms have the meanings indicated which are applicable to both the singular and plural thereof. Where an entire word is capitalized in the definitions and is found not capitalized in the Contract Documents it has the ordinary dictionary definition.

Addenda - Written or graphic instruments issued prior to the opening of Bids which make additions, deletions, or revisions to the Contract Documents.

Agreement - The written contract between the OWNER and the CONTRACTOR covering the WORK to be performed; other documents are attached to the Agreement and made a part thereof as listed out in the Agreement.

Application for Payment - The form furnished by the ENGINEER which is to be used by the CONTRACTOR to request progress or final payment and which is to be accompanied by such supporting documentation as is required by the Contract Documents.

Asbestos - Any material that contains more than one percent asbestos and is friable or is releasing asbestos fibers into the air above current action levels established by the United States Occupational Safety and Health Administration.

Bid - The offer or proposal of the Bidder submitted on the prescribed form setting forth the price or prices for the WORK.

Bonds - Bid, Performance, and Payment Bonds and other instruments which protect against loss due to inability or refusal of the CONTRACTOR to perform its contract.

Project Manager - The authorized representative of the City and Borough of Wrangell, as OWNER, who is responsible for administration of the contract.

Change Order - A document recommended by the ENGINEER, which is signed by the CONTRACTOR and the OWNER and authorizes an addition, deletion, or revision in the WORK, or an adjustment in the Contract Price or the Contract Time, issued on or after the Effective Date of the Agreement.

Contract Documents - The Table of Contents, Notice Inviting Bids, Instructions to Bidders, Bid Forms (including the Bid, Bid Schedule(s), Information Required of Bidder, Bid Bond, and all required certificates and affidavits), Agreement, Performance Bond, Payment Bond, General Conditions, Supplementary General Conditions, Technical Specifications, Drawings, Permits, and all Addenda, and Change Orders executed pursuant to the provisions of the Contract Documents.

Contract Price - The total monies payable by the OWNER to the CONTRACTOR under the terms and conditions of the Contract Documents.

Contract Time - The number of successive calendar days stated in the Contract Documents for the completion of the WORK.

CONTRACTOR - The individual, partnership, corporation, joint-venture or other legal entity with whom the OWNER has executed the Agreement.

Day - A calendar day of 24 hours measured from midnight to the next midnight.

## SECTION 00700 - GENERAL CONDITIONS

Defective WORK - WORK that is unsatisfactory, faulty, or deficient; or that does not conform to the Contract Documents; or that does not meet the requirements of any inspection, reference standard, test, or approval referred to in the Contract Documents; or WORK that has been damaged prior to the ENGINEER's recommendation of final payment.

Drawings - The Drawings, plans, maps, profiles, diagrams, and other graphic representations which indicate the character, location, nature, extent, and scope of the WORK and which have been prepared by the ENGINEER and are referred to in the Contract Documents. Shop Drawings are not within the meaning of this paragraph.

Effective Date of the Agreement - The date indicated in the Agreement on which it becomes effective, but if no such date is indicated it means the date on which the Agreement is signed and delivered by the last of the two parties to sign and deliver.

Engineer of Record - The individual, partnership, corporation, joint-venture or other legal entity named as such in the Contract Documents.

ENGINEER - The ENGINEER is the firm or person(s) selected by the OWNER to perform the duties of project inspection and management. Wrangell will inform the CONTRACTOR of the identity of the ENGINEER at or before the Notice to Proceed.

Field Order - A written order issued by the ENGINEER which may or may not involve a change in the WORK.

General Requirements - Division 1 of the Technical Specifications.

Hazardous Waste - The term Hazardous Waste shall have the meaning provided in Section 1004 of the Solid Waste Disposal Act (42 USC Section 9603) as amended from time to time.

Holidays - Legal holidays occur on:

1. New Year's Day - January 1
2. Martin Luther King's Birthday - Third Monday in January
3. President's Day - Third Monday in February
4. Seward's Day - Last Monday in March
5. Memorial Day - Last Monday in May
6. Independence Day - July 4
7. Labor Day - First Monday in September
8. Alaska Day - October 18
9. Veteran's Day - November 11
10. Thanksgiving Day - Fourth Thursday and the following Friday in November
11. Christmas Day - December 25

If any holiday listed above falls on a Saturday, Saturday and the preceding Friday are both legal holidays. If the holiday should fall on a Sunday, Sunday and the following Monday are both legal holidays.

Inspector - The authorized representative of the ENGINEER assigned to make detailed inspections for conformance to the Contract Documents. Any reference to the Resident Project Representative in this document shall mean the Inspector.

## SECTION 00700 - GENERAL CONDITIONS

Laws and Regulations; Laws or Regulations - Any and all applicable laws, rules, regulations, ordinances, codes, and/or orders of any and all governmental bodies, agencies, authorities and courts having jurisdiction.

Mechanic's Lien - A form of security, an interest in real property, which is held to secure the payment of an obligation. When referred to in these Contract Documents, "Mechanic's Lien" or "lien" means "Stop Notice".

Milestone - A principal event specified in the Contract Documents relating to an intermediate completion date of a portion of the WORK, or a period of time within which the portion of the WORK should be performed prior to Substantial Completion of all the WORK.

Notice of Intent to Award - The written notice by the OWNER to the apparent successful bidder stating that upon compliance by the apparent successful bidder with the requirements listed therein, within the time specified, the OWNER will enter into an Agreement.

Notice of Award - The written notice by the OWNER to the apparent successful bidder stating that the apparent successful bidder has complied with all conditions for award of the contract.

Notice of Substantial Completion - A form signed by the ENGINEER and the CONTRACTOR recommending to the OWNER that the WORK is Substantially Complete and fixing the date of Substantial Completion. After acceptance of the WORK by the OWNER's governing body, the form is signed by the OWNER and filed with the County Recorder. This filing starts the 30 day lien filing period on the WORK.

Notice to Proceed - The written notice issued by the OWNER to the CONTRACTOR authorizing the CONTRACTOR to proceed with the WORK and establishing the date of commencement of the Contract Time.

OWNER - The City and Borough of Wrangell, acting through its legally designated officials, officers, or employees.

Partial Utilization - Use by the OWNER or a substantially completed part of the WORK for the purpose for which it is intended prior to Substantial Completion of all the WORK.

PCB's - Polychlorinated biphenyls.

PERMITTEE – CONTRACTOR.

Petroleum - Petroleum, including crude oil or any fraction thereof which is liquid at standard conditions of temperature and pressure (60 degrees Fahrenheit and 14.7 pounds per square inch absolute), such as oil, petroleum, fuel oil, oil sludge, oil refuse, gasoline, kerosene, and oil mixed with other non-Hazardous Wastes and crude oils.

Project - The total construction of which the WORK to be provided under the Contract Documents may be the whole, or a part as indicated elsewhere in the Contract Documents.

Radioactive Material - Source, special nuclear, or byproduct material as defined by the Atomic Energy Act of 1954 (42 USC Section 2011 et seq.) as amended from time to time.

## SECTION 00700 - GENERAL CONDITIONS

Shop Drawings - All Drawings, diagrams, illustrations, schedules and other data which are specifically prepared by or for the CONTRACTOR and submitted by the CONTRACTOR, to the ENGINEER, to illustrate some portion of WORK.

Specifications - (Same definition as for Technical Specifications hereinafter).

Stop Notice - A legal remedy for Subcontractors and suppliers who contribute to public works, but who are not paid for their WORK, which secures payment from construction funds possessed by the OWNER. For public property, the Stop Notice remedy is designed to substitute for mechanic's lien rights.

Sub-Consultant - The individual, partnership, corporation, joint-venture or other legal entity having a direct contract with ENGINEER, or with any of its Consultants to furnish services with respect to the Project.

Subcontractor - An individual, partnership, corporation, joint-venture or other legal entity having a direct contract with the CONTRACTOR, or with any of its Subcontractors, for the performance of a part of the WORK at the site.

Substantial Completion - Refers to when the WORK has progressed to the point where, in the opinion of the ENGINEER as evidenced by Notice of Completion as applicable, it is sufficiently complete, in accordance with the Contract Documents, so that the WORK can be utilized for the purposes for which it is intended; or if no such notice is issued, when final payment is due in accordance with Paragraph 14.8. The terms "substantially complete" and "substantially completed" as applied to any WORK refer to substantial completion thereof.

Supplementary General Conditions (SGC) - The part of the Contract Documents which make additions, deletions, or revisions to these General Conditions.

Supplier - A manufacturer, fabricator, supplier, distributor, materialman, or vendor.

Technical Specifications - Divisions 1 through 16 of the Contract Documents consisting of the General Requirements and written technical descriptions of products and execution of the WORK.

Underground Utilities - All pipelines, conduits, ducts, cables, wires, manholes, vaults, tanks, tunnels, or other such facilities or attachments, and any encasements containing such facilities which have been installed underground to furnish any of the following services or materials: water, sewage and drainage removal, electricity, gases, steam, liquid petroleum products, telephone or other communications, cable television, traffic, or other control systems.

WORK - The entire completed construction or the various separately identifiable parts thereof required to be furnished under the Contract Documents. WORK is the result of performing or furnishing labor and furnishing and incorporating materials and equipment into the construction, and performing or furnishing services and furnishing documents, all as required by the Contract Documents.

### ARTICLE 2 PRELIMINARY MATTERS

2.1 DELIVERY OF BONDS/INSURANCE CERTIFICATES. When the CONTRACTOR delivers the signed Agreements to the OWNER, the CONTRACTOR shall also deliver to the OWNER such Bonds and Insurance Policies and Certificates as the CONTRACTOR may be required to furnish in accordance with the Contract Documents.



## **SECTION 00700 - GENERAL CONDITIONS**

- 2.2 COPIES OF DOCUMENTS. The OWNER shall furnish to the CONTRACTOR the required number of copies of the Contract Documents specified in the Supplementary General Conditions.
- 2.3 COMMENCEMENT OF CONTRACT TIME; NOTICE TO PROCEED. The Contract Time will start to run on the commencement date stated in the Notice to Proceed.
- 2.4 STARTING THE WORK
- A. The CONTRACTOR shall begin to perform the WORK within 10 days after the commencement date stated in the Notice to Proceed, but no WORK shall be done at the site prior to the commencement date, including mobilization.
- B. Before undertaking each part of the WORK, the CONTRACTOR shall carefully study and compare the Contract Documents and check and verify pertinent figures shown thereon and all applicable field measurements. The CONTRACTOR shall promptly report in writing to the ENGINEER any conflict, error, or discrepancy which the CONTRACTOR may discover and shall obtain a written interpretation or clarification from the ENGINEER before proceeding with any WORK affected thereby.
- C. The CONTRACTOR shall submit to the ENGINEER for review those documents called for under Section 01300 - Contractor Submittals in the General Requirements.
- 2.5 PRE-CONSTRUCTION CONFERENCE. The CONTRACTOR is required to attend a Pre-Construction Conference. This conference will be attended by the ENGINEER and others as appropriate in order to discuss the WORK in accordance with the applicable procedures specified in the General Requirements, Section 01010 - Summary of Work in the General Requirements.

### **ARTICLE 3 CONTRACT DOCUMENTS: INTENT, AMENDING, REUSE**

#### **3.1 INTENT**

- A. The Contract Documents comprise the entire Agreement between the OWNER and the CONTRACTOR concerning the WORK. The Contract Documents shall be construed as a whole in accordance with Alaska Law.
- B. It is the intent of the Contract Documents to describe the WORK, functionally complete, to be constructed in accordance with the Contract Documents. Any work, materials, or equipment that may reasonably be inferred from the Contract Documents as being required to produce the intended result shall be supplied whether or not specifically called for. When words or phrases which have a well-known technical or construction industry or trade meaning are used to describe work, materials, or equipment such words or phrases shall be interpreted in accordance with that meaning, unless a definition has been provided in Article 1 of the General Conditions. Reference to standard specifications, manuals, or codes of any technical society, organization, or association, or to the Laws or Regulations of any governmental authority, whether such reference be specific or by implication, shall mean the latest standard specification, manual, code, or Laws or Regulations in effect at the time of opening of Bids, except as may be otherwise specifically stated. However, no provision of any referenced standard specification, manual, or code (whether or not specifically incorporated by reference in the Contract Documents) shall be effective to change the duties and responsibilities of the OWNER,

## SECTION 00700 - GENERAL CONDITIONS

the CONTRACTOR, or the ENGINEER or any of their consultants, agents, or employees from those set forth in the Contract Documents.

- C. If, during the performance of the WORK, CONTRACTOR discovers any conflict, error, ambiguity or discrepancy within the Contract Documents or between the Contract Documents and any provision of any such Law or Regulation applicable to the performance of the WORK or of any such standard, specification, manual or code or of any instruction of any Supplier referred to in paragraph 6.5, the CONTRACTOR shall report it to the ENGINEER in writing at once, and the CONTRACTOR shall not proceed with the WORK affected thereby (except in an emergency as authorized by the ENGINEER) until a clarification field order, or Change Order to the Contract Documents has been issued.

### 3.2 ORDER OF PRECEDENCE OF CONTRACT DOCUMENTS

- A. In resolving conflicts resulting from, errors, or discrepancies in any of the Contract Documents, the order of precedence shall be as follows:

1. Permits from other agencies as may be required by law, excepting the definition of "PERMITEE" in these permits.
2. Field Orders
3. Change Orders
4. ENGINEER's written interpretations and clarifications.
5. Agreement
6. Addenda
7. CONTRACTOR's Bid (Bid Form)
8. Supplementary General Conditions
9. Notice Inviting Bids
10. Instructions to Bidders
11. General Conditions
12. Technical Specifications
13. Drawings

- B. With reference to the Drawings the order of precedence is as follows:

1. Figures govern over scaled dimensions
2. Detail Drawings govern over general Drawings
3. Addenda/ Change Order drawings govern over Contract Drawings
4. Contract Drawings govern over standard drawings

- 3.3 AMENDING AND SUPPLEMENTING CONTRACT DOCUMENTS. The Contract Documents may be amended to provide for additions, deletions, and revisions in the WORK or to modify the terms and conditions thereof by a Change Order (pursuant to Article 10 CHANGES IN THE WORK).

- 3.4 REUSE OF DOCUMENTS. Neither the CONTRACTOR, nor any Subcontractor or Supplier, nor any other person or organization performing any of the WORK under a contract with the OWNER shall have or acquire any title to or ownership rights in any of the Drawings, Technical Specifications, or other documents used on the WORK, and they shall not reuse any of them on the extensions of the Project or any other project without written consent of the OWNER.

## SECTION 00700 - GENERAL CONDITIONS

### ARTICLE 4 AVAILABILITY OF LANDS; PHYSICAL CONDITIONS; REFERENCE POINTS

4.1 AVAILABILITY OF LANDS. The OWNER shall furnish, as indicated in the Contract Documents, the lands upon which the WORK is to be performed, rights-of-way and easements for access thereto, and such other lands which are designated for the use of the CONTRACTOR. Easements for permanent structures or permanent changes in existing facilities will be obtained and paid for by the OWNER, unless otherwise provided in the Contract Documents. Nothing contained in the Contract Documents shall be interpreted as giving the CONTRACTOR exclusive occupancy of the lands or rights-of-way provided. The CONTRACTOR shall provide for all additional lands and access thereto that may be required for temporary construction facilities or storage of materials and equipment; provided, that the CONTRACTOR shall not enter upon nor use any property not under the control of the OWNER until a written temporary construction easement, lease or other appropriate agreement has been executed by the CONTRACTOR and the property owner, and a copy of said agreement furnished to the ENGINEER prior to said use; and, neither the OWNER nor the ENGINEER shall be liable for any claims or damages resulting from the CONTRACTOR's unauthorized trespass or use of any such properties.

#### 4.2 PHYSICAL CONDITIONS - SUBSURFACE AND EXISTING STRUCTURES

- A. Explorations and Reports. Reference is made to SGC 4.2 Physical Conditions of the Supplementary General Conditions for identification of those reports of explorations and tests of sub-surface conditions at the site that have been utilized by the ENGINEER in the preparation of the Contract Documents. The CONTRACTOR may rely upon the accuracy of the technical data contained in such reports, however, reports are not to be considered complete or comprehensive and nontechnical data, interpretations, and opinions contained in such reports shall be verified by the CONTRACTOR prior to bid. The CONTRACTOR is responsible for any further explorations or tests that may be necessary and any interpretation, interpolation, or extrapolation that it makes of any information shown in such reports.
- B. Existing Structures. Reference is made to SGC 4.2 Physical Conditions of the Supplementary General Conditions for identification of those drawings of physical conditions in or relating to existing surface and subsurface structures (except Underground Utilities referred to in Paragraph 4.4 herein) which are at or contiguous to the site that have been utilized by the ENGINEER in the preparation of the Contract Documents. The CONTRACTOR may rely upon the accuracy of the technical data contained in such drawings, however, nontechnical data, interpretations, and opinions contained in such drawings shall be verified by the CONTRACTOR prior to bid. The CONTRACTOR is also responsible for any interpretation, interpolation, or extrapolation that it makes of any information shown in such drawings.

#### 4.3 DIFFERING SITE CONDITIONS

- A. The CONTRACTOR shall promptly upon discovery (but in no event later than 14 days thereafter) and before the following conditions are disturbed, notify the ENGINEER, in writing of any:
1. Material that the CONTRACTOR believes may be material that is hazardous waste, as defined in Article 1 of these General Conditions, or asbestos, PCB's,

## SECTION 00700 - GENERAL CONDITIONS

petroleum or any other substance or material posing a threat to human or to the environment.

2. Subsurface or latent physical conditions at the site differing from those indicated in the reports referenced in SGC 4.2 Physical Conditions.
  3. Unknown physical conditions at the site of any unusual nature, differing materially from those physical conditions ordinarily encountered in the area of project and generally recognized as inherent in the area of the project and as ordinarily encountered and inherent in WORK of the character provided for in the contract. Weather conditions specifically do not constitute any change condition under this section.
- B. The OWNER shall promptly investigate the conditions, and if it finds that the conditions do materially so differ, or do involve hazardous waste, and cause a decrease or increase in the CONTRACTOR's cost of, or the time required for, performance of any part of the WORK shall issue a Change Order under the procedures described in the contract.
- C. In the event that a dispute arises between the OWNER and the CONTRACTOR whether the conditions materially differ, or involved hazardous waste or other materials listed above, or cause a decrease or increase in the CONTRACTOR's cost of, or time required for, performance of any part of the WORK, the CONTRACTOR shall not be excused from any scheduled completion date provided for by the contract, but shall proceed with all WORK to be performed under the contract. The CONTRACTOR and OWNER shall retain any and all rights provided either by contract or by Law which pertain to the resolution of disputes and protests between the contracting parties.

### 4.4 PHYSICAL CONDITIONS - UNDERGROUND UTILITIES

- A. Indicated. The information and data indicated in the Contract Documents with respect to existing Underground Utilities at or contiguous to the site are based on information and data furnished to the OWNER or the ENGINEER by the owners of such Underground Utilities or by others. Unless it is expressly provided in the Supplementary General Conditions and/or Section 01530 - Protection and Restoration of Existing Facilities of the General Requirements, the OWNER and the ENGINEER shall not be responsible for the accuracy or completeness of any such information or data, and the CONTRACTOR shall have full responsibility for reviewing and checking all such information and data, for locating all Underground Utilities indicated in the Contract Documents, for coordination of the WORK with the owners of such Underground Utilities during construction, for the safety and protection thereof and repairing any damage thereto resulting from the WORK, the cost of which will be considered as having been included in the Contract Price.
- B. Not Indicated. If an Underground Utility is uncovered or revealed at or contiguous to the site which was not indicated in the Contract Documents and which the CONTRACTOR could not reasonably have been expected to be aware of, the CONTRACTOR shall identify the owner of such Underground Utility and give written notice thereof to that owner and shall notify the ENGINEER in accordance with the requirements of the Supplementary General Conditions and Section 01530 - Protection and Restoration of Existing Facilities of the General Requirements.

## SECTION 00700 - GENERAL CONDITIONS

### 4.5 REFERENCE POINTS

- A. The ENGINEER will provide one benchmark, near or on the site of the WORK, and will provide two points near or on the site to establish a base line for use by the CONTRACTOR for alignment control. Unless otherwise specified in the General Requirements, the CONTRACTOR shall furnish all other lines, grades, and benchmarks required for proper execution of the WORK.
- B. The CONTRACTOR shall preserve all bench marks, stakes, and other survey marks, and in case of their removal or destruction by its own employees or by its Subcontractor's employees, the CONTRACTOR shall be responsible for the accurate replacement of such reference points by personnel qualified under the Alaska Statute governing the licensing of Architects, Engineers, and Land Surveyors.

## ARTICLE 5 BONDS AND INSURANCE

### 5.1 PERFORMANCE, PAYMENT, AND OTHER BONDS

- A. The CONTRACTOR shall furnish, when required, Performance and Payment Bonds on forms provided by the OWNER for the penal sums of 100% of the amount of the Bid award. The surety on each bond may be any corporation or partnership authorized to do business in the State of Alaska as an insurer under AS 21.09. These bonds shall remain in effect for 12 months after the date of final payment and until all obligations and liens under this contract have been satisfied. The CONTRACTOR shall also furnish such other Bonds as are required by the Supplementary General Conditions. All Bonds shall be in the form prescribed by the Contract Documents except as provided otherwise by Laws or Regulations, and shall be executed by such sureties as are named in the current list of "Companies Holding Certificates of Authority as Acceptable Sureties on Federal Bonds and as Acceptable Reinsuring Companies" as published in Circular 570 (amended) by the Audit Staff, Bureau of Government Financial Operations, U.S. Treasury Department. All Bonds signed by an agent must be accompanied by a certified copy of such agent's authority to act.
- B. If the surety on any Bond furnished by the CONTRACTOR is declared bankrupt or becomes insolvent or its right to do business is terminated in any state where any part of the WORK is located, the CONTRACTOR shall within 7 days thereafter substitute another Bond and Surety, which must be acceptable to the OWNER.
- C. All Bonds required by the Contract Documents to be purchased and maintained by CONTRACTOR shall be obtained from surety companies that are duly licensed or authorized in the State of Alaska to issue Bonds for the limits so required. Such surety companies shall also meet such additional requirements and qualifications as may be provided in the Supplementary General Conditions. The City Manager may, on behalf of the OWNER, notify the surety of any potential default or liability.

### 5.2 INSURANCE

- A. The CONTRACTOR shall purchase and maintain the insurance required under this paragraph. Such insurance shall include the specific coverages set out herein and be written for not less than the limits of liability and coverages provided in the Supplementary General Conditions, or required by law, whichever are greater. All

## SECTION 00700 - GENERAL CONDITIONS

insurance shall be maintained continuously during the life of the Agreement up to the date of Final Completion and at all times thereafter when the CONTRACTOR may be correcting, removing, or replacing Defective WORK in accordance with Paragraph 13.6, but the CONTRACTOR's liabilities under this Agreement shall not be deemed limited in any way to the insurance coverage required.

- B. All insurance required by the Contract Documents to be purchased and maintained by the CONTRACTOR shall be obtained from insurance companies that are duly licensed or authorized in the State of Alaska to issue insurance policies for the limits and coverages so required. Such insurance companies shall have a current Best's Rating of at least an "A" (Excellent) general policy holder's rating and a Class VII financial size category and shall also meet such additional requirements and qualifications as may be provided in the Supplementary General Conditions.
- C. The City and Borough of Wrangell shall be listed as an additional insured on the CONTRACTOR'S general liability insurance policy and the CONTRACTOR'S pollution liability policy. CONTRACTOR shall furnish certificates to the Borough of such insurance and showing the Borough as an additional insured within ten days of receiving the Notice to Proceed. Failure to comply with this provision constitutes a material breach and default of the Agreement.

## ARTICLE 6 CONTRACTOR'S RESPONSIBILITIES

### 6.1 SUPERVISION AND SUPERINTENDENCE

- A. The CONTRACTOR shall supervise, inspect, and direct the WORK competently and efficiently, devoting such attention thereto and applying such skills and expertise as may be necessary to perform the WORK in accordance with the Contract Documents. The CONTRACTOR shall be solely responsible for the means, methods, techniques, sequences, and procedures of construction and safety precautions and programs incidental thereto. The CONTRACTOR shall be responsible to see that the completed WORK complies accurately with the Contract Documents.
- B. The CONTRACTOR shall designate in writing and keep on the WORK site at all times during its progress a technically qualified, English-speaking superintendent, who is an employee of the CONTRACTOR and who shall not be replaced without written notice to the OWNER and the ENGINEER. The superintendent will be the CONTRACTOR's representative at the site and shall have authority to act on behalf of the CONTRACTOR. All communications given to the superintendent shall be as binding as if given to the CONTRACTOR. The CONTRACTOR shall issue all its communications to the OWNER through the ENGINEER and the ENGINEER only.
- C. The CONTRACTOR's superintendent shall be present at the site of the WORK at all times while WORK is in progress. Failure to observe this requirement shall be considered suspension of the WORK by the CONTRACTOR until such time as such superintendent is again present at the site.

## SECTION 00700 - GENERAL CONDITIONS

### 6.2 LABOR, MATERIALS, AND EQUIPMENT

- A. The CONTRACTOR shall provide competent, suitably qualified personnel to survey and lay out the WORK and perform construction as required by the Contract Documents. The CONTRACTOR shall furnish, erect, maintain, and remove the construction plant and any temporary works as may be required. The CONTRACTOR shall at all times maintain good discipline and order at the site. Except in connection with the safety or protection of persons or the WORK or property at the site or adjacent thereto, and except as otherwise indicated in the Contract Documents, all WORK at the site shall be performed during regular working hours, and the CONTRACTOR will not permit overtime work or the performance of work on Saturday, Sunday, or any legal holiday without the OWNER's written consent. The CONTRACTOR shall apply for this consent through the ENGINEER.
- B. Except as otherwise provided in this Paragraph, the CONTRACTOR shall receive no additional compensation for overtime work, i.e., work in excess of 8 hours in any one calendar day or 40 hours in any one calendar week, even though such overtime work may be required under emergency conditions and may be ordered by the ENGINEER in writing. Additional compensation will be paid the CONTRACTOR for overtime work only in the event extra work is ordered by the ENGINEER and the Change Order specifically authorizes the use of overtime work and then only to such extent as overtime wages are regularly being paid by the CONTRACTOR for overtime work of a similar nature in the same locality.
- C. All costs of inspection and testing performed during overtime work by the CONTRACTOR which is allowed solely for the convenience of the CONTRACTOR shall be borne by the CONTRACTOR. The OWNER shall have the authority to deduct the cost of all such inspection and testing from any partial payments otherwise due to the CONTRACTOR.
- D. Unless otherwise specified in the Contract Documents, the CONTRACTOR shall furnish and assume full responsibility for all materials, equipment, labor, transportation, construction equipment and machinery, tools, appliances, fuel, power, light, heat, telephone, water, sanitary facilities, and all other facilities and incidentals necessary for the furnishing, performance, testing, start-up, and completion of the WORK, including all mobilization and demobilization.
- E. All materials and equipment to be incorporated into the WORK shall be of good quality and new, except as otherwise provided in the Contract Documents. All warranties and guarantees specifically called for by the Specifications shall expressly run to the benefit of the OWNER. If required by the ENGINEER, the CONTRACTOR shall furnish satisfactory evidence (including reports of required tests) as to the kind and quality of materials and equipment. All materials and equipment shall be applied, installed, connected, erected, used, cleaned, and conditioned in accordance with the instructions of the applicable Supplier except as otherwise provided in the Contract Documents; but no provisions of any such instructions will be effective to assign to the ENGINEER, or any of the ENGINEER consultants, agents, or employees, any duty or authority to supervise or direct the furnishing or performance of the WORK or any duty or authority to undertake responsibility contrary to the provisions of Paragraphs 9.9C and 9.9D.

## SECTION 00700 - GENERAL CONDITIONS

- F. The CONTRACTOR shall at all times employ sufficient labor and equipment for prosecuting the several classes of WORK to full completion in the manner and time set forth in and required by these specifications. All workers shall have sufficient skill and experience to perform properly the WORK assigned to them. Workers engaged in special WORK, or skilled WORK, shall have sufficient experience in such WORK and in the operation of the equipment required to perform all WORK, properly and satisfactorily.
- G. Any person employed by the CONTRACTOR or by any Subcontractor who, in the opinion of the ENGINEER, does not perform the WORK in a proper and skillful manner, or is intemperate or disorderly shall, at the written request of the ENGINEER, be removed forthwith by the CONTRACTOR or Subcontractor employing such person, and shall not be employed again in any portion of the WORK without the approval of the ENGINEER. Should the CONTRACTOR fail to remove such person or persons as required above, or fail to furnish suitable and sufficient personnel for the proper prosecution of the WORK, the ENGINEER may suspend the WORK by written notice until such orders are complied with.
- 6.3 ADJUSTING PROGRESS SCHEDULE. The CONTRACTOR shall submit monthly updates of the progress schedule to the ENGINEER for acceptance in accordance with the provisions in Section 01300 - Contractor Submittals in the General Requirements.
- 6.4 SUBSTITUTES OR "OR-EQUAL" ITEMS. The CONTRACTOR shall submit proposed substitutes or "or-equal" items in accordance with the provisions in Section 01300 - Contractor Submittals in the General Requirements.
- 6.5 CONCERNING SUBCONTRACTORS, SUPPLIERS, AND OTHERS.
- A. The CONTRACTOR shall be responsible to the OWNER and the ENGINEER for the acts and omissions of its Subcontractors and their employees to the same extent as CONTRACTOR is responsible for the acts and omissions of its own employees. Nothing contained in this Paragraph shall create any contractual relationship between any Subcontractor and the OWNER or the ENGINEER nor relieve the CONTRACTOR of any liability or obligation under the Agreement and Contract documents.
- B. The CONTRACTOR shall perform not less than 40% of the WORK with its own forces (i.e., without subcontracting). The 40% requirement shall be understood to mean that the CONTRACTOR shall perform, with its own organization, WORK amounting to at least 40% of the awarded contract amount. The 40% requirement will be calculated based upon the total of the subcontract amounts submitted for contract award, and any other information requested by the OWNER from the apparent low bidder.
- 6.6 PERMITS
- A. Unless otherwise provided in the Supplementary General Conditions, the CONTRACTOR shall obtain and pay for all construction permits and licenses from the agencies having jurisdiction, including the furnishing of insurance and bonds if required by such agencies. The enforcement of such requirements under this contract shall not be made the basis for claims for additional compensation. The OWNER shall assist the CONTRACTOR, when necessary, in obtaining such permits and licenses. The CONTRACTOR shall pay all governmental charges and inspection fees necessary for the



## SECTION 00700 - GENERAL CONDITIONS

prosecution of the WORK, which are applicable at the time of opening of Bids. The CONTRACTOR shall pay all charges of utility owners for connections to the WORK.

- B. These Contract Documents may require that the WORK be performed within the conditions and/or requirements of local, state and/or federal permits. These permits may be bound within the Contract Documents, included within the Contract Documents by reference, or included as part of the WORK, as designated in this Section. The CONTRACTOR is responsible for completing the WORK required for compliance with all permit requirements; this WORK is incidental to other items in the Contract Documents. Any reference to the “permittee” in the permits shall mean the CONTRACTOR. If any permits were acquired by the OWNER, this action was done to expedite the start of construction. If the CONTRACTOR does not complete the WORK within the specified permit window, the CONTRACTOR shall be responsible for the permit extension, and for completing any additional requirements placed upon the permit.
  - C. These Contract Documents may require that the WORK be performed within the conditions and/or requirements of local, state and/or federal permits. These permits may be bound within the Contract Documents, included within the Contract Documents by reference, or included as part of the WORK, as designated in Section 00700 – General Conditions, Article 6.6 - PERMITS. The CONTRACTOR is responsible for completing the WORK required for compliance with all permit requirements; this WORK is incidental to other items in the Contract Documents. Any reference to the “permittee” in the permits shall mean the CONTRACTOR. If any permits were acquired by the OWNER, this action was done to expedite the start of construction. If the CONTRACTOR does not complete the WORK within the specified permit window, the CONTRACTOR shall be responsible for the permit extension, and for completing any additional requirements placed upon the permit.
  - D. The OWNER shall apply for, and obtain, the necessary building permit for this project, however, the CONTRACTOR is responsible for scheduling and coordinating all necessary inspections. All other provisions of this Section remain in effect.
- 6.7 PATENT FEES AND ROYALTIES. The CONTRACTOR shall pay all license fees and royalties and assume all costs incident to the use in the performance of the WORK or the incorporation in the WORK of any invention, design, process, product, software or device which is the subject of patent rights or copyrights held by others. If a particular invention, design, process, product, or device is specified in the Contract Documents for use in the performance of the WORK and if to the actual knowledge of the OWNER or the ENGINEER its use is subject to patent rights or copyrights calling for the payment of any license fee or royalty to others, the existence of such rights shall be disclosed by the OWNER in the Contract Documents. The CONTRACTOR shall indemnify, defend and hold harmless the OWNER and the ENGINEER and anyone directly or indirectly employed by either of them from and against all claims, damages, losses, and expenses (including attorneys’ fees and court costs) arising out of any infringement of patent rights or copyrights incident to the use in the performance of the WORK or resulting from the incorporation in the WORK of any invention, design, process, product, or device not specified in the Contract Documents, and shall defend all such claims in connection with any alleged infringement of such rights.
- 6.8 LAWS AND REGULATIONS. The CONTRACTOR shall observe and comply with all federal, state, and local laws, ordinances, codes, orders, and regulations which in any manner affect those engaged or employed on the WORK, the materials used in the WORK, or the conduct of the

## SECTION 00700 - GENERAL CONDITIONS

WORK. If any discrepancy or inconsistency should be discovered in this contract in relation to any such law, ordinance, code, order, or regulation, the CONTRACTOR shall report the same in writing to the ENGINEER. The CONTRACTOR shall indemnify, defend, and hold harmless the OWNER, the ENGINEER, and their officers, agents, and employees against all claims or liability arising from violation of any such law, ordinance, code, order, or regulation, whether by CONTRACTOR or by its employees, Subcontractors, or third parties. Any particular law or regulation specified or referred to elsewhere in the Contract Documents shall not in any way limit the obligation of the CONTRACTOR to comply with all other provisions of federal, state, and local laws and regulations.

The OWNER may, per AS 36.30, audit the CONTRACTOR's or Subcontractor(s) records that are related to the cost or pricing data for this contract, all related Change Orders, and/or contract modifications.

- 6.9 TAXES. The CONTRACTOR shall pay all sales, consumer, use, and other similar taxes required to be paid by the CONTRACTOR in accordance with the Laws and Regulations of the place of the Project which are applicable during the performance of the WORK.
- 6.10 USE OF PREMISES. The CONTRACTOR shall confine construction equipment, the storage of materials and equipment, and the operations of workers to (1) the Project site, (2) the land and areas identified in and permitted by the Contract Documents, and (3) the other land and areas permitted by Laws and Regulations, rights-of-way, permits, leases and easements. The CONTRACTOR shall assume full responsibility for any damage to any such land or area, or to the owner or occupant thereof or of any land or areas contiguous thereto, resulting from the performance of the WORK. Should any claim be made against the OWNER or the ENGINEER by any such owner or occupant because of the performance of the WORK, the CONTRACTOR shall promptly attempt to settle with such other party by agreement or otherwise resolve the claim through litigation. The CONTRACTOR shall, to the fullest extent permitted by Laws and Regulations, indemnify, defend, and hold the OWNER and the ENGINEER harmless from and against all claims, damages, losses, and expenses (including, but not limited to, fees of engineers attorneys, and other professionals and court costs) arising directly, indirectly, or consequentially out of any action, legal or equitable, brought by any such owner or occupant against the OWNER, the ENGINEER, their Consultants, Sub-consultants, and the officers, directors, employees and agents of each and any of them to the extent caused by or based upon the CONTRACTOR's performance or non-performance of the WORK.
- 6.11 SAFETY AND PROTECTION
- A. The CONTRACTOR shall be responsible for initiating, maintaining, and supervising all safety precautions and programs in connection with the WORK. The CONTRACTOR shall take all necessary precautions for the safety of, and shall provide the necessary protection to prevent damage, injury or loss to:
1. all employees on the WORK and other persons and organizations who may be affected thereby;
  2. all the WORK and materials and equipment to be incorporated therein, whether in storage on or off the site; and
  3. other property at the site or adjacent thereto, including trees, shrubs, lawns, walks, pavements, roadways, structures, and utilities not designated for removal, relocation, or replacement in the course of construction.

## SECTION 00700 - GENERAL CONDITIONS

- B. The CONTRACTOR shall comply with all applicable Laws and Regulations whether referred to herein or not) of any public body having jurisdiction for the safety of persons or property or to protect them from damage, injury, or loss and shall erect and maintain all necessary safeguards for such safety and protection. The CONTRACTOR shall notify owners of adjacent property and utilities when prosecution of the WORK may affect them, and shall cooperate with them in the protection, removal, relocation, and replacement of their property.
- C. The CONTRACTOR shall designate a qualified and experienced safety representative at the site whose duties and responsibilities shall be the prevention of accidents and the maintaining and supervising of safety precautions and program.
- D. Materials that contain hazardous substances or mixtures may be required on the WORK. A Material Safety Data Sheet shall be requested by the CONTRACTOR from the manufacturer of any hazardous product used.
- E. Material usage shall be accomplished with strict adherence to all safety requirements and all manufacturer's warnings and application instructions listed on the Material Safety Data Sheet and on the product container label.
- F. The CONTRACTOR shall be responsible for coordinating communications on any exchange of Material Safety Data Sheets or other hazardous material information that is required to be made available to, or exchanged between, or among, employers at the site in accordance with Laws or Regulations.
- G. The CONTRACTOR shall notify the ENGINEER if it considers a specified product or its intended usage to be unsafe. This notification must be given to the ENGINEER prior to the product being ordered, or if provided by some other party, prior to the product being incorporated in the WORK.

### 6.12 SHOP DRAWINGS AND SAMPLES

- A. After checking and verifying all field measurements and after complying with applicable procedures specified in the General Requirements, the CONTRACTOR shall submit to the ENGINEER for review, all Shop Drawings in accordance with Section 01300 - Contractor Submittals in the General Requirements.
- B. The Contractor shall also submit to the ENGINEER for review all samples in accordance with Section 01300 - Contractor Submittals in the General Requirements.
- C. Before submittal of each shop drawing or sample, the CONTRACTOR shall have determined and verified all quantities, dimensions, specified performance criteria, installation requirements, materials, catalog numbers, and similar data with respect thereto and reviewed or coordinated each Shop Drawing or sample with other Shop Drawings and samples and with the requirements of the WORK and the Contract Documents.

- 6.13 CONTINUING THE WORK. The CONTRACTOR shall carry on the WORK and adhere to the progress schedule during all disputes or disagreements with the OWNER. No work shall be delayed or postponed pending resolution of any disputes or disagreements, except as the CONTRACTOR and the OWNER may otherwise agree in writing.

## SECTION 00700 - GENERAL CONDITIONS

### 6.14 INDEMNIFICATION

- A. To the fullest extent permitted by the laws of the State of Alaska, the CONTRACTOR shall indemnify, defend, and hold harmless the OWNER, the ENGINEER, their Consultants, Sub-consultants and the officers, assembly members, mayor, directors, employees, and agents of each and any of them, against and from all claims, actions, damages, and liability of any kind and any nature arising out of or related to in way any acts or omissions of the CONTRACTOR, including death, and including in any administrative action by any federal or state agency, except where the claim or action alleges willful misconduct of the OWNER and the ENGINEER. Such indemnification by the CONTRACTOR shall include but not be limited to the following:
1. Liability or claims resulting directly or indirectly from the negligence or carelessness of the CONTRACTOR, its employees, or agents in the performance of the WORK, or non-performance of the WORK, or in guarding or maintaining the same, or from any improper materials, implements, or appliances used in its construction, or by or on account of any act or omission of the CONTRACTOR, its employees, agents, or third parties;
  2. Liability or claims arising directly or indirectly from bodily injury, occupational sickness or disease, or death of the CONTRACTOR's or Subcontractor's own employees engaged in the WORK resulting in actions brought by or on behalf of such employees against the OWNER, and the ENGINEER;
  3. Liability or claims arising directly or indirectly from or based on the violation of any federal, state or local law, ordinance, regulation, order, or decree, whether by the CONTRACTOR, its employees, or agents;
  4. Liability or claims arising directly or indirectly from the use or manufacture by the CONTRACTOR, its employees, or agents in the performance of this contract of any copyrighted or non-copyrighted composition, secret process, patented or non-patented invention, computer software, article, or appliance, unless otherwise specifically stipulated in this contract.
  5. Liability or claims arising directly or indirectly from the breach of any warranties, whether express or implied, made to the OWNER or any other parties by the CONTRACTOR, its employees, or agents;
  6. Liabilities or claims arising directly or indirectly from the willful or criminal misconduct of the CONTRACTOR, its employees, or agents; and,
  7. Liabilities or claims arising directly or indirectly from any breach of the obligations of the CONTRACTOR in the Agreement and all Contract documents.
- B. The CONTRACTOR shall reimburse the ENGINEER and the OWNER for all costs and expenses, (including but not limited to fees and charges of engineers, attorneys, experts, and other professionals and court costs including all costs of appeals) incurred by the OWNER, and the ENGINEER in enforcing the provisions of this Paragraph 6.14.
- C. The indemnification obligation under this Paragraph 6.14 shall not be limited in any way by any limitation of the amount or type of damages, compensation, or benefits payable by or for the CONTRACTOR or any such Subcontractor or other person or organization under workers' compensation acts, disability benefit acts, or other employee benefit acts.

6.15 CONTRACTOR'S DAILY REPORTS. The CONTRACTOR shall complete a daily report indicating total manpower for each construction trade, major equipment on site, each

## SECTION 00700 - GENERAL CONDITIONS

Subcontractor's manpower, weather conditions, etc., involved in the performance of the WORK. The daily report shall be completed on forms provided by the ENGINEER and shall be submitted to the ENGINEER at the conclusion of each workday. The report should comment on the daily progress and status of the WORK within each major component of the WORK. These components will be decided by the ENGINEER.

- 6.16 ASSIGNMENT OF CONTRACT. The CONTRACTOR shall not assign, sublet, sell, transfer, or otherwise dispose of the contract or any portion thereof, or its right, title, or interest therein, or obligations thereunder, without the written consent of the OWNER except as imposed by law. If the CONTRACTOR violates this provision, the contract may be terminated at the sole option of the OWNER. In such event, the OWNER shall be relieved of all liability and obligations to the CONTRACTOR and to its assignee or transferee, growing out of such termination.
- 6.17 CONTRACTOR'S RESPONSIBILITY FOR UTILITY PROPERTY AND SERVICES. It is understood that any turn-on or turn-off, line locates and any other work or assistance necessary by the OWNER, will be at the CONTRACTOR's expense unless otherwise stated in the bid documents. All cost must be agreed to prior to any related actions and will be considered incidental to the project cost. Billing to the CONTRACTOR will be direct from the OWNER.
- 6.18 OPERATING WATER SYSTEM VALVES
- A. The CONTRACTOR shall submit a written request, to the ENGINEER, for approval to operate any valve on any in-service section of the City water system. The request must be submitted at least 24-hours prior to operating any valves. The request shall specifically identify each valve to be operated, the time of operation, and the operation to be performed. The CONTRACTOR shall obtain the written approval of the ENGINEER for any scheduled operation before operating any valve.
- B. The CONTRACTOR shall be responsible for all damages, both direct and consequential, to the OWNER or any other party, caused by unauthorized operation of any valve of the City water system.
- 6.19 CONTRACTOR'S WORK SCHEDULE LIMITATIONS. City and Borough of Wrangell Noise Ordinance. The noise loudness measured at the boundary line of the premises used for industrial activities shall not exceed 90 decibels between the hours of 7:00 AM and 8:00 PM on weekdays and the hours of 10:00 AM and 8:00 PM on weekends and holidays, and 40 decibels at other hours, unless a permit shall first be obtained from the OWNER. Such permit shall be issued by the OWNER only upon a determination that such operation during hours not otherwise permitted hereunder is necessary and will not result in unreasonable disturbance to surrounding residents.

## ARTICLE 7 OTHER WORK

### 7.1 RELATED WORK AT SITE

- A. The OWNER may perform other work related to the Project at the site by the OWNER's own forces, have other work performed by utility owners, or let other direct contracts therefor which may contain General Conditions similar to these. If the fact that such other work is to be performed was not noted in the Contract Documents, written notice thereof will be given to the CONTRACTOR prior to starting any such other work.

## SECTION 00700 - GENERAL CONDITIONS

- B. The CONTRACTOR shall afford each other contractor who is a party to such a direct contract and each utility owner (or the OWNER, if the OWNER is performing the additional work with the OWNER's employees) proper and safe access to the site and a reasonable opportunity for the introduction and storage of materials and equipment and the execution of such work, and shall properly connect and coordinate the WORK with theirs. The CONTRACTOR shall do all cutting, fitting, and patching of the WORK that may be required to make its several parts come together properly and integrate with such other work. The CONTRACTOR shall not endanger any work of others by cutting, excavating, or otherwise altering their work and will only cut or alter their work with the written consent of the ENGINEER and the others whose work will be affected.
- C. If the proper execution or results of any part of the CONTRACTOR's WORK depends upon the work of any such other contractor or utility owner (or OWNER), the CONTRACTOR shall inspect and report to the ENGINEER in writing any delays, defects, or deficiencies in such other work that render it unavailable or unsuitable for such proper execution and results. The CONTRACTOR's failure to report such delays, defects, or deficiencies will constitute an acceptance of the other work as fit and proper for integration with the CONTRACTOR's WORK except for latent or nonapparent defects and deficiencies in the other work.

7.2 COORDINATION. If the OWNER contracts with others for the performance of other work on the Project at the site, the person or organization who will have authority and responsibility for coordination of the activities among the various prime contractors will be identified in the Supplementary General Conditions, and the specific matters to be covered by such authority and responsibility will be itemized and the extent of such authority and responsibilities will be provided in the Supplementary General Conditions.

### ARTICLE 8 OWNER'S RESPONSIBILITIES

#### 8.1 COMMUNICATIONS

- A. The OWNER shall issue all its communications to the CONTRACTOR through the ENGINEER.
- B. The CONTRACTOR shall issue all its communications to the OWNER through the ENGINEER.

8.2 PAYMENTS. The OWNER shall make payments to the CONTRACTOR as provided in Paragraphs 14.5, 14.8, 14.9 and 14.10.

8.3 LANDS, EASEMENTS, AND SURVEYS. The OWNER's duties in respect of providing lands and easements and providing surveys to establish reference points are set forth in Paragraphs 4.1 and 4.5.

8.4 CHANGE ORDERS. The OWNER shall execute Change Orders as indicated in Paragraph 10.1F.

8.5 INSPECTIONS AND TESTS. The OWNER's responsibility in respect of inspections, tests, and approvals is set forth in Paragraph 13.3.

8.6 SUSPENSION OF WORK. In connection with the OWNER's right to stop WORK or suspend WORK, see Paragraphs 13.4 and 15.1.

## SECTION 00700 - GENERAL CONDITIONS

- 8.7 TERMINATION OF AGREEMENT. Paragraphs 15.2 and 15.3 detail the OWNER's right to terminate services of the CONTRACTOR.

### ARTICLE 9 ENGINEER'S STATUS DURING CONSTRUCTION

- 9.1 OWNER'S REPRESENTATIVE. The ENGINEER will be the OWNER's representative during the construction period. The duties and responsibilities and the limitations of authority of the ENGINEER as the OWNER's representative during construction are set forth in the Contract Documents.
- 9.2 VISITS TO SITE. The ENGINEER will make visits to the site during construction to observe the progress and quality of the WORK and to determine, in general, if the WORK is proceeding in accordance with the Contract Documents. Exhaustive or continuous on-site inspections to check the quality or quantity of the WORK will not be required of the ENGINEER. The ENGINEER will not, during such visits, or as a result of such observations of the CONTRACTOR's WORK in progress, supervise, direct, or have control over the CONTRACTOR's WORK.
- 9.3 PROJECT REPRESENTATION. The ENGINEER may furnish an Inspector to assist in observing the performance of the WORK. The duties, responsibilities, and limitations of authority are as follows:

A. Duties, Responsibilities and Limitations of Authority of Inspector

General. The Inspector, who is the ENGINEER's Agent, will act as directed by and under the supervision of the ENGINEER and will confer with the ENGINEER regarding its actions. The Inspector's dealings in matters pertaining to the on-site WORK shall, in general, be only with the ENGINEER and the CONTRACTOR, and dealings with Subcontractors shall only be through or with the full knowledge of the CONTRACTOR. Written communication with the OWNER will be only through or as directed by the ENGINEER.

Duties and Responsibilities. The Inspector will:

1. Review the progress schedule, list of Shop Drawing submittals and schedule of values prepared by the CONTRACTOR and consult with the ENGINEER concerning their acceptability.
2. Attend pre-construction conferences. Arrange a schedule of progress meetings and other job conferences as required in consultation with the ENGINEER and notify those expected to attend in advance. Attend meetings and maintain and circulate copies of minutes thereof.
3. Serve as the ENGINEER's liaison with the CONTRACTOR, working principally through the CONTRACTOR's superintendent and assist said superintendent in understanding the intent of the Contract Documents. Assist the ENGINEER in serving as the OWNER's liaison with the CONTRACTOR when the CONTRACTOR's operations affect the OWNER's on-site operations.
4. As requested by the ENGINEER, assist in obtaining from the OWNER additional details or information, when required at the site for proper execution of the WORK.
5. Receive and record date of receipt of Shop Drawings and samples, receive samples which are furnished at the site by the CONTRACTOR and notify the ENGINEER of their availability for examination.

## SECTION 00700 - GENERAL CONDITIONS

6. Conduct on-site observations of the WORK in progress to assist the ENGINEER in determining if the WORK is proceeding in accordance with the Contract Documents.
7. Report to the ENGINEER whenever the Inspector believes that any WORK is unsatisfactory, faulty, or defective or does not conform to the Contract Documents, or does not meet the requirements of any inspection, tests or approval required to be made or has been damaged prior to final payment; and advise the ENGINEER when the Inspector believes WORK should be corrected or rejected or should be uncovered for observation, or requires special testing, inspection, or approval.
8. Verify that the tests, equipment, and systems startups and operating and maintenance instruction are conducted as required by the Contract Documents and in presence of the required personnel, and that the CONTRACTOR maintains adequate records thereof; observe, record and report to the ENGINEER appropriate details relative to the test procedures and start-ups.
9. Accompany visiting inspectors representing public or other agencies having jurisdiction over the WORK, record the outcome of these inspections, and report to the ENGINEER.
10. Transmit to the CONTRACTOR the ENGINEER's clarifications and interpretations of the Contract Documents.
11. Consider and evaluate the CONTRACTOR's suggestions for modifications in the Contract Documents and report them with recommendations to the ENGINEER.
12. Maintain at the job site orderly files for correspondence, reports of job conferences, Shop Drawings and sample submittals, reproductions of original Contract Documents including all addenda, Change Orders, field orders, additional Drawings issued subsequent to the execution of the contract, the ENGINEER's clarifications and interpretations of the Contract Documents, progress reports, and other related documents.
13. Keep a diary or log book, recording hours on the job site, weather conditions, data relative to questions of extras or deductions, list all project visitors, daily activities, decisions, observations in general, and specific observations in more detail as in the case of performing and observing test procedures. Send copies to the ENGINEER.
14. Record names, addresses, and telephone numbers of the CONTRACTOR, Subcontractors, and major suppliers of materials and equipment.
15. Furnish the ENGINEER with periodic reports as required of progress of the WORK and the CONTRACTOR's compliance with the accepted progress schedule and schedule of CONTRACTOR submittals.
16. Consult with the ENGINEER in advance of scheduled major tests, inspections, or start of important phases of the WORK.
17. Report immediately to the ENGINEER upon the occurrence of any accident.
18. Review applications for payment with the CONTRACTOR for compliance with the established procedure for their submittal and forward them with recommendations to the ENGINEER, noting particularly their relation to the schedule of values, WORK completed, and materials and equipment delivered at the site but not incorporated in the WORK.
19. During the course of the WORK, verify that certificates, maintenance and operation manuals, and other data required to be assembled and furnished by the CONTRACTOR are applicable to the items actually installed; and deliver this material to the ENGINEER for its review and forwarding to the OWNER prior to final acceptance of the WORK.



## SECTION 00700 - GENERAL CONDITIONS

20. Before the ENGINEER prepares a Certificate of Substantial Completion/Notice of completion, as applicable, review the CONTRACTOR's punch list items requiring completion or correction and add any items that CONTRACTOR has omitted.
21. Conduct final inspection in the company of the ENGINEER, the OWNER, and the CONTRACTOR, and prepare a final punch list of items to be completed or corrected.
22. Verify that all items on the punch list have been completed or corrected and make recommendations to the ENGINEER concerning acceptance.

Limitations of Authority. Except upon written instruction of the ENGINEER, the Inspector:

1. Shall not authorize any deviation from the Contract Documents or approve any substitute material or equipment.
2. Shall not exceed limitations on the ENGINEER's authority as set forth in the Contract Documents.
3. Shall not undertake any of the responsibilities of the CONTRACTOR, Subcontractors or CONTRACTOR's superintendent, or expedite the WORK.
4. Shall not advise on or issue directions relative to any aspect of the means, methods, techniques, sequences, or procedures of construction unless such is specifically called for in the Contract Documents.
5. Shall not advise on or issue directions as to safety precautions and programs in connection with the WORK.

9.4 CLARIFICATIONS AND INTERPRETATIONS. The ENGINEER will issue with reasonable promptness such written clarifications or interpretations of the requirements of the Contract Documents (in the form of Drawings or otherwise) as the ENGINEER may determine necessary, which shall be consistent with, or reasonably inferred from, the overall intent of the Contract Documents.

9.5 AUTHORIZED VARIATIONS IN WORK. The ENGINEER may authorize variations in the WORK from the requirements of the Contract Documents. These may be accomplished by a Field Order and will require the CONTRACTOR to perform the WORK involved in a manner that minimizes the impact to the WORK and the contract completion date. If the CONTRACTOR believes that a Field Order justifies an increase in the Contract Price or an extension of the Contract Time, the CONTRACTOR may make a claim therefor as provided in Article 11 or 12.

9.6 REJECTING DEFECTIVE WORK. The ENGINEER will have authority to reject WORK which the ENGINEER believes to be defective and will also have authority to require special inspection or testing of the WORK as provided in Paragraph 13.3G, whether or not the WORK is fabricated, installed, or completed.

9.7 CONTRACTOR SUBMITTALS, CHANGE ORDERS, AND PAYMENTS

- A. In accordance with the procedures set forth in the General Requirements, the ENGINEER will review all CONTRACTOR submittals, including Shop Drawings, samples, substitutes, or "or equal" items, etc., in order to determine if the items covered by the submittals will, after installation or incorporation in the WORK, conform to the requirements of the Contract Documents and be compatible with the design concept of the completed project as a functioning whole as indicated by the Contract Documents.

## SECTION 00700 - GENERAL CONDITIONS

The ENGINEER's review will not extend to means, methods, techniques, sequences or procedures of construction or to safety precautions or programs incident thereto.

- B. In connection with the ENGINEER's responsibilities as to Change Orders, see Articles 10, 11, and 12.
- C. In connection with the ENGINEER's responsibilities in respect of Applications for Payment, see Article 14.

### 9.8 DECISIONS ON DISPUTES

- A. The ENGINEER will be the initial interpreter of the requirements of the Contract Documents and judge of the acceptability of the WORK thereunder. Claims, disputes, and other matters relating to the acceptability of the WORK; the interpretation of the requirements of the Contract Documents pertaining to the performance of the WORK; and those claims under Articles 11 and 12 in respect to changes in the Contract Price or Contract Time will be referred initially to the ENGINEER in writing with a request for formal decision in accordance with this paragraph, which the ENGINEER will render in writing within 30 days of receipt of the request. Written notice of each such claim, dispute, and other matter will be delivered by the CONTRACTOR to the ENGINEER promptly (but in no event later than 30 days) after the occurrence of the event giving rise thereto. Written supporting data will be submitted to the ENGINEER within 60 days after such occurrence unless the ENGINEER allows an additional period of time to ascertain more accurate data in support of the claim. The failure of the CONTRACTOR to provide all supporting documentation for the claim shall result in the denial of the claim and the waiver of the claim by the CONTRACTOR.
- B. The rendering of a decision by the ENGINEER with respect to any such claim, dispute, or other matter (except any which have been waived by the making or acceptance of final payment as provided in Paragraph 14.12) will be a condition precedent to any exercise by the OWNER or the CONTRACTOR of such rights or remedies as either may otherwise have under the Contract Documents or by Law or Regulations in respect of any such claim, dispute, or other matter.

### 9.9 LIMITATION ON ENGINEER'S RESPONSIBILITIES

- A. Neither the ENGINEER's authority to act under this Article or other provisions of the Contract Documents nor any decision made by the ENGINEER in good faith either to exercise or not exercise such authority shall give rise to any duty or responsibility of the ENGINEER to the CONTRACTOR, any Subcontractor, any Supplier, any surety for any of them, or any other person or organization performing any of the WORK.
- B. Whenever in the Contract Documents the terms "as ordered," "as directed," "as required," "as allowed," "as reviewed," "as approved," or terms of like effect or import are used, or the adjectives "reasonable," "suitable," "acceptable," "proper," or "satisfactory" or adjectives of like effect or import are used to describe a requirement, direction, review, or judgment of the ENGINEER as to the WORK, it is intended that such requirement, direction, review, or judgment will be solely to evaluate the WORK for compliance with the requirements of the Contract Documents, and conformance with the design concept of the completed Project as a functioning whole as indicated by the Contract Documents, unless there is a specific statement indicating otherwise. The use of

## SECTION 00700 - GENERAL CONDITIONS

any such term or adjective shall not be effective to assign to the ENGINEER any duty or authority to supervise or direct the performance of the WORK or any duty or authority to undertake responsibility contrary to the provisions of Paragraph 9.9C or 9.9D.

- C. The ENGINEER will not supervise, direct, control, or have authority over or be responsible for the CONTRACTOR's means, methods, techniques, sequences, or procedures of construction, or the safety precautions and programs incident thereto, or for any failure of the CONTRACTOR to comply with Laws and Regulations, applicable to the performance of the WORK. The ENGINEER will not be responsible for the CONTRACTOR's failure to perform the WORK in accordance with the Contract Documents, except where the failure of the CONTRACTOR is the result of negligent acts or omissions of the ENGINEER in the ENGINEER's performance of its obligations.
- D. The ENGINEER will not be responsible for the acts or omissions of the CONTRACTOR nor of any Subcontractor, supplier, or any other person or organization performing any of the WORK.

### ARTICLE 10 CHANGES IN THE WORK

#### 10.1 GENERAL

- A. Without invalidating the Agreement and without notice to any surety, the OWNER may at any time or from time to time, order additions, deletions, or revisions in the WORK; these will be authorized by a written Field Order and/or a Change Order issued by the ENGINEER.
- B. If the CONTRACTOR believes that it is entitled to an increase or decrease in the Contract Price, or an extension or shortening in the Contract Time as the result of a Field Order, a claim may be made as provided in Articles 11 and 12.
- C. If the OWNER and CONTRACTOR agree on the value of any work, or the amount of Contract Time that should be allowed as a result of a Field Order, upon receiving written notice from the ENGINEER, the CONTRACTOR shall proceed so as to minimize the impact on and delays to the work pending the issuance of a Change Order.
- D. If the OWNER and the CONTRACTOR are unable to agree as to the extent, if any, of an increase or decrease in the Contract Price or an extension or shortening of the Contract Time that should be allowed as a result of a Field Order, the ENGINEER can direct the CONTRACTOR to proceed on the basis of Time and Materials so as to minimize the impact on and delays to WORK, and a claim may be made therefor as provided in Articles 11 and 12.
- E. The CONTRACTOR shall not be entitled to an increase in the Contract Price nor an extension of the Contract Time with respect to any work performed that is not required by the Contract Documents as amended, modified, supplemented by Change Order, except in the case of an emergency and except in the case of uncovering work as provided in Paragraph 13.3G.
- F. The OWNER and the CONTRACTOR shall execute appropriate Change Orders covering:

## SECTION 00700 - GENERAL CONDITIONS

1. changes in the WORK which are ordered by the OWNER pursuant to Paragraph 10.1A;
  2. changes required because of acceptance of Defective WORK under Paragraph 13.7;
  3. changes in the Contract Price or Contract Time which are agreed to by the parties; or
  4. changes in the Contract Price or Contract Times which embody the substance of any written decision rendered by the ENGINEER pursuant to Paragraph 9.8.
- G. If notice of any change is required by the provisions of any Bond to be given to a surety, the giving of any such notice will be the CONTRACTOR's responsibility, and the amount of each applicable Bond shall be adjusted accordingly.

### 10.2 ALLOWABLE QUANTITY VARIATIONS

- A. In the event of an increase or decrease in Bid item quantity of a unit price contract, the total amount of WORK actually done or materials or equipment furnished shall be paid for according to the unit bid price established for such WORK under the Contract Documents, wherever such unit price has been established; provided, that an adjustment in the Contract Price may be made for changes which result in an increase or decrease in excess of 25% of the estimated quantity of any major item of the WORK. Major Item is defined as any bid item amount that is ten percent (10%) or more of the total contract amount.
- B. In the event a part of the WORK is to be entirely eliminated and no lump sum or unit price is named in the Contract Documents to cover such eliminated work, the price of the eliminated work shall be agreed upon in writing by the OWNER and the CONTRACTOR. If the OWNER and the CONTRACTOR fail to agree upon the price of the eliminated work, the price shall be determined in accordance with the provisions of Article 11.

## ARTICLE 11 CHANGE OF CONTRACT PRICE

### 11.1 GENERAL

- A. The Contract Price constitutes the total compensation payable to the CONTRACTOR for performing the WORK. All duties, responsibilities, and obligations assigned to or undertaken by the CONTRACTOR to complete the WORK shall be at its expense without change in the Contract Price.
- B. The Contract Price may only be changed by a Change Order approved by the Borough Assembly. Any claim for an increase in the Contract Price shall be based on written notice delivered by the CONTRACTOR to the ENGINEER promptly (but in no event later than 7 days) after the start of the occurrence or the event giving rise to the claim and stating the general nature of the claim. Notice of the amount of the claim with all supporting documentation and data shall be delivered within 14 days after such occurrence (unless the ENGINEER allows an additional period of time to ascertain more accurate data in support of the claim) and shall be accompanied by the CONTRACTOR's written statement that the amount claimed covers all known amounts (direct, indirect, and consequential) to which the CONTRACTOR is entitled as a result of the occurrence or event. All claims for adjustment in the Contract Price shall be determined by the

## SECTION 00700 - GENERAL CONDITIONS

ENGINEER in accordance with Paragraph 9.8A if the OWNER and the CONTRACTOR cannot otherwise agree on the amount involved. No claim for an adjustment in the Contract Price will be valid if not submitted in accordance with this Paragraph 11.1B.

- C. The value of any work covered by a Change Order or of any claim for an increase or decrease in the Contract Price shall be determined in one of the following ways:
1. Where the work involved is covered by unit prices contained in the Contract Documents, by application of unit prices to the quantities of the items involved. Unit prices not specified in the contract documents shall be determined by the unit price for that item or items in the CONTRACTOR'S bid.
  2. By mutual acceptance of a lump sum, which may, but is not required to, include an allowance for overhead and profit not necessarily in accordance with Paragraph 11.4.
  3. On the basis of the cost of work (determined as provided in Paragraphs 11.3) plus a CONTRACTOR's fee for overhead and profit (determined as provided in Paragraph 11.4).

11.2 COSTS RELATING TO WEATHER. The CONTRACTOR shall have no claims against the OWNER for damages for any injury to WORK, materials, or equipment, resulting from the action of the elements. If, however, in the opinion of the ENGINEER, the CONTRACTOR has made all reasonable efforts to protect the materials, equipment and work, the CONTRACTOR may be granted a reasonable extension of Contract Time to make proper repairs, renewals, and replacements of the work, materials, or equipment.

### 11.3 COST OF WORK (BASED ON TIME AND MATERIALS)

- A. General. The term "cost of work" means the sum of all costs actually and necessarily incurred and paid by the CONTRACTOR for labor, materials, and equipment in the proper performance of extra work. Except as otherwise may be agreed to in writing by the OWNER, such costs shall be in amounts no higher than those prevailing in the locality of the Project; shall include only the following items, and shall not include any of the costs itemized in Paragraph 11.5 EXCLUDED COSTS.
- B. Labor. The costs of labor will be the actual cost for wages prevailing for each craft or type of workers performing the extra work at the time the extra work is done, plus employer payments of payroll taxes, worker's compensation insurance, liability insurance, health and welfare, pension, vacation, apprenticeship funds, and other direct costs resulting from Federal, State or local laws, as well as assessments or benefits required by lawful collective bargaining agreements. Labor costs for equipment operators and helpers shall be paid only when such costs are not included in the invoice for equipment rental. The labor costs for forepersons shall be proportioned to all of their assigned work and only that applicable to extra work shall be paid. Non-direct labor costs including superintendence shall be considered part of the mark-up set out in paragraph 11.4.
- C. Materials. The cost of materials reported shall be at invoice or lowest current price at which materials are locally available and delivered to the job in the quantities involved, plus the cost of freight, delivery and storage, subject to the following:

## SECTION 00700 - GENERAL CONDITIONS

1. Trade discounts available to the purchaser shall be credited to the OWNER notwithstanding the fact that such discounts may not have been taken by the CONTRACTOR.
  2. For materials secured by other than a direct purchase and direct billing to the purchaser, the cost shall be deemed to be the price paid to the actual supplier as determined by the ENGINEER. Mark-up except for actual costs incurred in the handling of such materials will not be allowed.
  3. Payment for materials from sources owned wholly or in part by the purchaser shall not exceed the price paid by the purchaser for similar materials from said sources on extra work items or the current wholesale price for such materials delivered to the work site, whichever price is lower.
  4. If in the opinion of the ENGINEER the cost of material is excessive, or the CONTRACTOR does not furnish satisfactory evidence of the cost of such material, then the cost shall be deemed to be the lowest current wholesale price for the quantity concerned delivered to the work site less trade discount. The OWNER reserves the right to furnish materials for the extra work and no claim shall be allowed by the CONTRACTOR for costs and profit on such materials.
- D. Equipment. The CONTRACTOR will be paid for the use of equipment at the rental rate listed for such equipment specified in the Supplementary General Conditions. Such rental rate will be used to compute payments for equipment whether the equipment is under the CONTRACTOR's control through direct ownership, leasing, renting, or another method of acquisition. The rental rate to be applied for use of each item of equipment shall be the rate resulting in the least total cost to the OWNER for the total period of use. If it is deemed necessary by the CONTRACTOR to use equipment not listed in the publication specified in the Supplementary General Conditions, an equitable rental rate for the equipment will be established by the ENGINEER. The CONTRACTOR may furnish cost data which might assist the ENGINEER in the establishment of the rental rate. The CONTRACTOR shall not be entitled for any rental rate for equipment the use of which would have necessary to provide the unit of work and which should have been included in the CONTRACTOR'S bid price for that unit of work.
1. All equipment shall, in the opinion of the ENGINEER, be in good working condition and suitable for the purpose for which the equipment is to be used.
  2. Before construction equipment is used on the extra work, the CONTRACTOR shall plainly stencil or stamp an identifying number thereon at a conspicuous location, and shall furnish to the ENGINEER, in duplicate, a description of the equipment and its identifying number.
  3. Unless otherwise specified, manufacturer's ratings and manufacturer approved modifications shall be used to classify equipment for the determination of applicable rental rates. Equipment which has no direct power unit shall be powered by a unit of at least the minimum rating recommended by the manufacturer.
  4. Individual pieces of equipment or tools having a replacement value of \$200 or less, whether or not consumed by use, shall be considered to be small tools and no payment will be made therefor.
  5. Rental time will not be allowed while equipment is inoperative due to breakdowns.
  6. Equipment Rental Rates. Unless otherwise agreed in writing, the CONTRACTOR will be paid for the use of equipment at the rental rate listed for such equipment specified in the current edition of the following reference publication: "Rental Rate Blue Book" as published by Dataquest (a company of the Dunn and Bradstreet

## SECTION 00700 - GENERAL CONDITIONS

Corporation), 1290 Ridder Park Drive, San Jose, CA 95131, telephone number (800) 227-8444.

- E. Equipment on the Work Site. The rental time to be paid for equipment on the work site shall be the time the equipment is in productive operation on the extra work being performed and, in addition, shall include the time required to move the equipment to the location of the extra work and return it to the original location or to another location requiring no more time than that required to return it to its original location; except, that moving time will not be paid if the equipment is used on other than the extra work, even though located at the site of the extra work, or if it was not necessary to move equipment from another location to the site. Loading and transporting costs will be allowed, in lieu of moving time, when the equipment is moved by means other than its own power, except that no payment will be made for loading and transporting costs when the equipment is used at the site of the extra work on other than the extra work. The following shall be used in computing the rental time of equipment on the work site.
1. When hourly rates are listed, any part of an hour less than 30 minutes of operation shall be considered to be 1/2-hour of operation, and any part of an hour in excess of 30 minutes will be considered one hour of operation.
  2. When daily rates are listed, any part of a day less than 4 hours operation shall be considered to be 1/2-day of operation. When owner-operated equipment is used to perform extra work to be paid for on a time and materials basis, the CONTRACTOR will be paid for the equipment and operator, as set forth in Paragraphs (3), (4), and (5), following.
  3. Payment for the equipment will be made in accordance with the provisions in Paragraph 11.3D, herein.
  4. Payment for the cost of labor and subsistence or travel allowance will be made at the rates paid by the CONTRACTOR to other workers operating similar equipment already on the work site, or in the absence of such labor, established by collective bargaining agreements for the type of worker and location of the extra work, whether or not the operator is actually covered by such an agreement. A labor surcharge will be added to the cost of labor described herein in accordance with the provisions of Paragraph 11.3B, herein, which surcharge shall constitute full compensation for payments imposed by state and federal laws and all other payments made to or on behalf of workers other than actual wages.
  5. To the direct cost of equipment rental and labor, computed as provided herein, will be added the allowances for equipment rental and labor as provided in Paragraph 11.4, herein.
- F. Specialty Work. Specialty work is defined as that work characterized by extraordinary complexity, sophistication, or innovation or a combination of the foregoing attributes which are unique to the construction industry. The following shall apply in making estimates for payment for specialty work:
1. Any bid item of WORK to be classified as Specialty Work shall be listed as such in the Supplementary General Conditions. Specialty work shall be performed by an entity especially skilled in the work to be performed. After validation of invoices and determination of market values by the ENGINEER, invoices for specialty work based upon the current fair market value thereof may be accepted without complete itemization of labor, material, and equipment rental costs.

**SECTION 00700 - GENERAL CONDITIONS**

- 2. When the CONTRACTOR is required to perform work necessitating special fabrication or machining process in a fabrication or a machine shop facility away from the job site, the charges for that portion of the work performed at the off-site facility may, by agreement, be accepted as specialty work and accordingly, the invoices for the work may be accepted without detailed itemization.
- 3. All invoices for specialty work will be adjusted by deducting all trade discounts offered or available, whether the discounts were taken or not. In lieu of the allowances for overhead and profit specified in Paragraph 11.4, herein, an allowance of 5 percent will be added to invoices for specialty work.

G. Sureties. All work performed hereunder shall be subject to all of the provisions of the Contract Documents and the CONTRACTOR’s sureties shall be bound with reference thereto as under the original Agreement. Copies of all amendments to surety bonds or supplemental surety bonds shall be submitted to the OWNER for review prior to the performance of any work hereunder.

**11.4 CONTRACTOR’S FEE**

A. Extra work ordered on the basis of time and materials will be paid for at the actual necessary cost as determined by the ENGINEER, plus allowances for overhead and profit. The allowance for overhead and profit shall include full compensation for superintendence, bond and insurance premiums, taxes, field office expense, extended overhead, home office overhead, and all other items of expense or cost not included in the cost of labor, materials, or equipment provided for under Paragraph 11.3. The allowance for overhead and profit will be made in accordance with the following schedule:

Actual Overhead and Profit Allowance	
Labor .....	15 percent
Materials.....	10 percent
Equipment .....	10 percent

To the sum of the costs and mark-ups provided for in this Article, one percent shall be added as compensation for bonding.

B. It is understood that labor, materials, and equipment may be furnished by the CONTRACTOR or by the Subcontractor on behalf of the CONTRACTOR. When all or any part of the extra work is performed by a Subcontractor, the allowance specified herein shall be applied to the labor, materials, and equipment costs of the Subcontractor, to which the CONTRACTOR may add 5 percent of the Subcontractor’s total cost for the extra work. Regardless of the number of hierarchical tiers of Subcontractors, the 5 percent increase above the Subcontractor’s total cost which includes the allowances for overhead and profit specified herein may be applied one time only.

**11.5 EXCLUDED COSTS.** The term Cost of the Work shall not include any of the following:

A. Payroll costs and other compensation of CONTRACTOR’s officers, executives, principals (of partnership and sole proprietorships), general managers, engineers, estimators, attorneys’ auditors, accountants, purchasing and contracting agents, expenditures, timekeepers, clerks and other personnel employed by CONTRACTOR whether at the site or in CONTRACTOR’s principal or a branch office for general administration of the work, or not



## SECTION 00700 - GENERAL CONDITIONS

specifically covered by paragraph 11.3, all of which are to be considered administrative costs covered by the CONTRACTOR's fee.

- B. Expenses of CONTRACTOR's principal and branch offices other than CONTRACTOR's office at the site.
- C. Any part of CONTRACTOR's capital expenses, including interest on CONTRACTOR's capital employed for the Work and charges against CONTRACTOR for delinquent payments.
- D. Cost of premiums for all bonds and for all insurance whether or not CONTRACTOR is required by the Contract Documents to purchase and maintain the same (except for the cost of premiums covered by paragraph 11.4 above).
- E. Costs due to the negligence of CONTRACTOR, any Subcontractor, or anyone directly or indirectly employed by any of them or for whose acts any of them may be liable, including but not limited to, the correction of Defective WORK, disposal of materials or equipment wrongly supplied and making good any damage to property.
- F. Other overhead or general expense costs of any kind and the cost of any item not specifically and expressly included in paragraph 11.4.
- G. Equipment rental cost for equipment that would be needed to perform the unit of work as reflected in the bid price for that unit of work.
- H. Mobilization or demobilization for equipment that would necessarily have been used to perform that unit of work as reflected in the bid price for that unit of work.

## ARTICLE 12 CHANGE OF CONTRACT TIME

### 12.1 GENERAL

- A. The Contract Time may only be changed by a Change Order. Any claim for an extension of the Contract Time (or Milestones) shall be based on written notice delivered by the CONTRACTOR to the ENGINEER promptly (but in no event later than 30 days) after the occurrence of the event giving rise to the claim and stating the general nature of the claim. Notice of the extent of the claim with supporting data shall be delivered within 60 days after such occurrence (unless the ENGINEER allows an additional period of time to ascertain more accurate data in support of the claim) and shall be accompanied by the CONTRACTOR'S written statement that the adjustment claimed is the entire adjustment to which the CONTRACTOR has reason to believe it is entitled as a result of the occurrence of said event. All claims for adjustment in the Contract Time shall be determined by the ENGINEER in accordance with Paragraph 9.8 if the OWNER and the CONTRACTOR cannot otherwise agree. No claim for an adjustment in the Contract Time will be valid if not submitted in accordance with the requirements of this Paragraph 12.1A. An increase in Contract Time does not mean that the Contractor is due an increase in Contract Price. Only Compensable time extensions will result in an increase in Contract Price.
- B. All time limits stated in the Contract Documents are of the essence of the Agreement. OWNER reserves the right to direct CONTRACTOR to accelerate his work, at no cost to OWNER, if CONTRACTOR fails to maintain contract schedule.

## SECTION 00700 - GENERAL CONDITIONS

- C. Where CONTRACTOR is prevented from completing any part of the Work within the Contract Times (or Milestones) due to delay beyond the control of CONTRACTOR, the Contract Times (or Milestones) will be extended in an amount equal to the time lost on the critical path of the project due to such delay if a claim is made therefor as provided in paragraph 12.1. Delays beyond the control of CONTRACTOR shall include, but not be limited to, acts or neglect of utility owners or other contractors performing other work as contemplated by Article 7, fires, floods, epidemics, unprecedented weather conditions or acts of God. Delays attributable to and within the control of a Subcontractor or Supplier shall be deemed to be delays within the control of CONTRACTOR.
- D. Where CONTRACTOR is prevented from completing any part of the WORK within the Contract Times (or Milestones) due to delay beyond the control of both OWNER and CONTRACTOR, an extension of the Contract Times (or Milestones) in an amount equal to the time lost on the critical path of the project due to such delay shall be CONTRACTOR's sole and exclusive remedy for such delay. In no event shall the OWNER be liable to CONTRACTOR, any Subcontractor, any Supplier, or any other person or organization, or to any surety for or employee or agent of any of them, for damages arising out of or resulting from (i) delays caused by or within the control of CONTRACTOR, or (ii) delays beyond the control of both parties including but not limited to fires, floods, epidemics abnormal weather conditions, acts of God or acts or neglect by utility owners or other contractors performing other work as contemplated by Article 7.

12.2 EXTENSIONS OF TIME FOR DELAY DUE TO WEATHER. Contract Time may be extended by the ENGINEER because of delays in completion of the WORK due to unusually severe weather, provided that the CONTRACTOR shall, within 10 days of the beginning of any such delay, notify the ENGINEER in writing of the cause of delay and request an extension of Contract Time. The ENGINEER will ascertain the facts and the extent of the delay and extend the time for completing the work when, in the ENGINEER's judgment, the findings of fact justify such an extension. Unprecedented, abnormal, or unusually severe weather will be defined as an event, or events, with a greater than 50-year recurrence interval, as determined by the National Weather Service, or equivalent State or Federal agency

### **ARTICLE 13 WARRANTY AND GUARANTEE; TESTS AND INSPECTIONS; CORRECTION, REMOVAL, OR ACCEPTANCE OF DEFECTIVE WORK**

- 13.1 WARRANTY AND GUARANTEE. The CONTRACTOR warrants and guarantees to the OWNER and the ENGINEER that all work will be in accordance with the Contract Documents and will not be defective. Prompt notice of defects known to the OWNER or ENGINEER shall be given to the CONTRACTOR. All defective work, whether or not in place, may be rejected, corrected, or accepted as provided in this Article 13.
- 13.2 ACCESS TO WORK. OWNER, ENGINEER, their Consultants, sub-consultants, other representatives and personnel of OWNER, independent testing laboratories and governmental agencies with jurisdictional interests will have access to the Work at reasonable times for their observation, inspecting and testing. CONTRACTOR shall provide them proper and safe conditions for such access and advise them of CONTRACTOR's site safety procedures and programs so that they may comply therewith as applicable.

## SECTION 00700 - GENERAL CONDITIONS

### 13.3 TESTS AND INSPECTIONS

- A. The CONTRACTOR shall give the ENGINEER timely notice of readiness of the WORK for all required inspections, tests, or approvals, and shall cooperate with inspection and testing personnel to facilitate required inspections or tests.
- B. If Laws or Regulations of any public body having jurisdiction other than the OWNER require any WORK to specifically be inspected, tested, or approved, the CONTRACTOR shall pay all costs in connection therewith. The CONTRACTOR shall also be responsible for and shall pay all costs in connection with any inspection or testing required in connection with the OWNER's or the ENGINEER's acceptance of a Supplier of materials or equipment proposed as a substitution or (or-equal) to be incorporated in the WORK, or of materials or equipment submitted for review prior to the CONTRACTOR's purchase thereof for incorporation in the WORK. The cost of all inspections, tests, and approvals in addition to the above which are required by the Contract Documents shall be paid by the OWNER (unless otherwise specified).
- C. The ENGINEER will make, or have made, such inspections and tests as the ENGINEER deems necessary to see that the WORK is being accomplished in accordance with the requirements of the Contract Documents. Unless otherwise specified in the Supplementary General Conditions, the cost of such inspection and testing will be borne by the OWNER. In the event such inspections or tests reveal non-compliance with the requirements of the Contract Documents, the CONTRACTOR shall bear the cost of corrective measures deemed necessary by the ENGINEER, as well as the cost of subsequent reinspection and retesting. Neither observations by the ENGINEER nor inspections, tests, or approvals by others shall relieve the CONTRACTOR from the CONTRACTOR's obligation to perform the WORK in accordance with the Contract Documents.
- D. All inspections, tests, or approvals other than those required by Laws or Regulations of any public body having jurisdiction shall be performed by organizations acceptable to the ENGINEER and the CONTRACTOR.
- E. If any work (including the work of others) that is to be inspected, tested, or approved is covered without written concurrence of the ENGINEER, it must, if requested by the ENGINEER, be uncovered for observation. Such uncovering shall be at the CONTRACTOR's expense unless the CONTRACTOR has given the ENGINEER timely notice of the CONTRACTOR's intention to perform such test or to cover the same and the ENGINEER has not acted with reasonable promptness in response to such notice.
- F. If any WORK is covered contrary to the written request of the ENGINEER, it must, if requested by the ENGINEER, be uncovered for the ENGINEER's observation and recovered at the CONTRACTOR's expense.
- G. If the ENGINEER considers it necessary or advisable that covered WORK be observed by the ENGINEER or inspected or tested by others, the CONTRACTOR, at the ENGINEER's request, shall uncover, expose, or otherwise make available for observation, inspection, or testing as the ENGINEER may require, that portion of the WORK in question, furnishing all necessary labor, material, and equipment. If it is found that such work is defective, the CONTRACTOR shall bear all direct, indirect, and consequential costs and damages of such uncovering, exposure, observation, inspection,

## SECTION 00700 - GENERAL CONDITIONS

and testing and of satisfactory reconstruction, including but not limited to fees and charges of engineers, attorneys, and other professionals. However, if such work is not found to be defective, the CONTRACTOR shall be allowed an increase in the Contract Price or an extension of the Contract Time, or both, directly attributable to such uncovering, exposure, observation, inspection, testing, and reconstruction; and, if the parties are unable to agree as to the amount or extent thereof, the CONTRACTOR may make a claim therefor as provided in Articles 11 and 12.

- 13.4 OWNER MAY STOP THE WORK. If the WORK is defective, or the CONTRACTOR fails to perform work in such a way that the completed WORK will conform to the Contract Documents, the OWNER may order the CONTRACTOR to stop the WORK, or any portion thereof, until the cause for such order has been eliminated; however, this right of the OWNER to stop the WORK shall not give rise to any duty on the part of the OWNER to exercise this right for the benefit of the CONTRACTOR or any other party.
- 13.5 CORRECTION OR REMOVAL OF DEFECTIVE WORK. If required by the ENGINEER, the CONTRACTOR shall promptly, either correct all defective work, whether or not fabricated, installed, or completed, or, if the WORK has been rejected by the ENGINEER, remove it from the site and replace it with non-defective work. The CONTRACTOR shall bear all direct, indirect and consequential costs and damages of such correction or removal, including but not limited to fees and charges of engineers, attorneys, and other professionals made necessary thereby.
- 13.6 ONE YEAR CORRECTION PERIOD
- A. If within one year after the date of Substantial Completion or such longer period of time as may be prescribed by Laws or Regulations or by the terms of any applicable special guarantee required by the Contract Documents or by any specific provision of the Contract Documents, any work is found to be defective, the CONTRACTOR shall promptly, without cost to the OWNER and in accordance with OWNER's written notification, (i) correct such Defective WORK, or, if it has been rejected by the OWNER, remove it from the site and replace it with non-defective work, and (ii) satisfactorily correct or remove and replace any damage to other work of others resulting therefrom. If the CONTRACTOR does not promptly comply with such notification, or in an emergency where delay would cause serious risk of loss or damage, the OWNER may have the Defective WORK corrected or the rejected WORK removed and replaced, and all direct, indirect, and consequential costs and damages of such removal and replacement including but not limited to fees and charges of engineers, attorneys and other professionals will be paid by the CONTRACTOR.
- B. Where Defective WORK (and damage to other WORK resulting therefrom) has been corrected, removed or replaced under this paragraph 13.6, the correction period hereunder with respect to such WORK will be extended for an additional period of one year after such correction or removal and replacement has been satisfactorily completed.
- 13.7 ACCEPTANCE OF DEFECTIVE WORK. If, instead of requiring correction or removal and replacement of defective work, the OWNER prefers to accept the WORK, the OWNER may do so. The CONTRACTOR shall bear all direct, indirect, and consequential costs attributable to the OWNER's evaluation of and determination to accept such defective work. If any such acceptance occurs prior to final payment, a Change Order will be issued incorporating the necessary revisions in the Contract Documents with respect to the WORK, and the OWNER shall be entitled to an appropriate decrease in the Contract Price.

## SECTION 00700 - GENERAL CONDITIONS

### ARTICLE 14 PAYMENTS TO CONTRACTOR AND COMPLETION

- 14.1 SCHEDULE OF VALUES (LUMP SUM PRICE BREAKDOWN). The schedule of values or lump sum price breakdown established as provided in the General Requirements shall serve as the basis for progress payments and will be incorporated into a form of Application for Payment acceptable to the ENGINEER.
- 14.2 UNIT PRICE BID SCHEDULE. Progress payments on account of Unit Price work will be based on the number of units completed.
- 14.3 APPLICATION FOR PROGRESS PAYMENT
- A. Unless otherwise prescribed by law, on the 25th of each month, the CONTRACTOR shall submit to the ENGINEER for review, an Application for Payment filled out and signed by the CONTRACTOR covering the WORK completed as of the date of the Application and accompanied by such supporting documentation as is required by the Contract Documents.
- B. The Application for Payment shall identify, as a sub-total, the amount of the CONTRACTOR'S Total Earnings to Date, plus the Value of Materials Stored at the Site which have not yet been incorporated in the WORK, and less a deductive adjustment for materials installed which were not previously incorporated in the WORK, but for which payment was allowed under the provisions for payment for Materials Stored at the Site, but not yet incorporated in the WORK.
- C. Each Application for Payment shall be submitted with an updated Progress Schedule, as required in Section 01300 Contractor Submittals. Each Application for Payment will also be accompanied by Contractor and Subcontractor certified payroll reports for periods covered by the period covered by the Application for Payment.
- D. The Net Payment Due the CONTRACTOR shall be the above-mentioned subtotal from which shall be deducted the total amount of all previous payments made to the CONTRACTOR. Progress payments will be paid in full in accordance with Article 14 of the General Conditions until 90% of the Contract Price has been paid. The remaining 10% of the Contract Price amount may be withheld until:
1. final inspection has been made;
  2. completion of the project; and
  3. acceptance of the project by the OWNER.
- E. The Value of Materials Stored at the Site shall be an amount equal to the specified percent of the value of such materials as set forth in the Supplementary General Conditions. Said amount shall be based upon the value of all acceptable materials and equipment not incorporated in the WORK but delivered and suitably stored at the site or at another location agreed to in writing; provided, each such individual item has a value of more than \$5,000.00 and will become a permanent part of the WORK. The Application for Payment shall also be accompanied by an invoice (including shipping), a certification that the materials meet the applicable contract specifications, and any evidence required by the OWNER that the materials and equipment are covered by appropriate property insurance and other arrangements to protect the OWNER's interest

## SECTION 00700 - GENERAL CONDITIONS

therein, all of which will be satisfactory to the OWNER. Payment for materials will not constitute final acceptance. It shall be the CONTRACTOR's responsibility to protect the material from damage, theft, loss, or peril while in storage. Unless otherwise prescribed by law, the Value of Materials Stored at the Site shall be paid at the invoice amount up to a maximum of 85% of the Contract Price for those items.

14.4 CONTRACTOR'S WARRANTY OF TITLE. The CONTRACTOR warrants and guarantees that title to all work, materials, and equipment covered by an Application for Payment, whether incorporated in the WORK or not, will pass to the OWNER no later than the time of payment free and clear of all liens.

14.5 REVIEW OF APPLICATIONS FOR PROGRESS PAYMENT

- A. The ENGINEER will, within 7 days after receipt of each Application for Payment, either indicate in writing a recommendation of payment and present the Application to the OWNER, or return the Application to the CONTRACTOR indicating in writing the ENGINEER's reasons for refusing to recommend payment. In the later case, the CONTRACTOR may make the necessary corrections and resubmit the Application, at which point the 7 days for ENGINEER review will begin again. If the ENGINEER still disagrees with a portion of the Application, it will submit the Application recommending the undisputed portion of the Application to the OWNER for payment and provide reasons for recommending non-payment of the disputed amount. Thirty days after presentation of the Application for Payment with the ENGINEER's recommendation, the amount recommended will (subject to the provisions of Paragraph 14.5B) become due and when due will be paid by the OWNER to the CONTRACTOR.
- B. The OWNER may refuse to make payment of the full amount recommended by the ENGINEER because claims have been made against the OWNER on account of the CONTRACTOR's performance of the WORK or Liens have been filed in connection with the WORK or there are other items entitling the OWNER to a credit against the amount recommended, but the OWNER must give the CONTRACTOR written notice within 7 days (with a copy to the ENGINEER) stating the reasons for such action.

14.6 PARTIAL UTILIZATION

- A. The OWNER shall have the right to utilize or place into service any item of equipment or other usable portion of the WORK prior to completion of the WORK. Whenever the OWNER plans to exercise said right, the CONTRACTOR will be notified in writing by the OWNER, identifying the specific portion or portions of the WORK to be so utilized or otherwise placed into service.
- B. It shall be understood by the CONTRACTOR that until such written notification is issued, all responsibility for care and maintenance of all of the WORK shall be borne by the CONTRACTOR. Upon issuance of said written notice of partial utilization, the OWNER will accept responsibility for the protection and maintenance of all such items or portions of the WORK described in the written notice.
- C. The CONTRACTOR shall retain full responsibility for satisfactory completion of the WORK, regardless of whether a portion thereof has been partially utilized by the OWNER and the CONTRACTOR's one year correction period shall commence only after the date of Substantial Completion for the WORK.

## SECTION 00700 - GENERAL CONDITIONS

- 14.7 SUBSTANTIAL COMPLETION. When the CONTRACTOR considers the WORK ready for its intended use the CONTRACTOR shall notify the OWNER and the ENGINEER in writing that the WORK is substantially complete. The CONTRACTOR will attach to this request a list of all work items that remain to be completed and a request that the ENGINEER prepare a Notice of Completion. Within a reasonable time thereafter, the OWNER, the CONTRACTOR, and the ENGINEER shall make an inspection of the WORK to determine the status of completion. If the ENGINEER does not consider the WORK substantially complete, or the list of remaining work items to be comprehensive, the ENGINEER will notify the CONTRACTOR in writing giving the reasons therefor. If the ENGINEER considers the WORK substantially complete, the ENGINEER will prepare and deliver to the OWNER, for its execution and recording, the Notice of Completion signed by the ENGINEER and CONTRACTOR, which shall fix the date of Substantial Completion.
- 14.8 FINAL APPLICATION FOR PAYMENT. After the CONTRACTOR has completed all of the remaining work items referred to in Paragraph 14.7 and delivered all maintenance and operating instructions, schedules, guarantees, Bonds, certificates of inspection, contract releases, record as-built documents (as provided in the General Requirements) and other documents, all as required by the Contract Documents, and after the ENGINEER has indicated that the WORK is acceptable, the CONTRACTOR may make application for final payment following the procedure for progress payments. The final Application for Payment shall be accompanied by all documentation called for in the Contract Documents, together with complete and legally effective releases or waivers (satisfactory to the OWNER) of all liens arising out of or filed in connection with the WORK.
- 14.9 FINAL PAYMENT AND ACCEPTANCE
- A. If, on the basis of the ENGINEER's observation of the WORK during construction and final inspection, and the ENGINEER's review of the final Application for Payment and accompanying documentation, all as required by the Contract Documents, the ENGINEER is satisfied that the WORK has been completed and the CONTRACTOR's other obligations under the Contract Documents have been fulfilled, the ENGINEER will, within 14 days after receipt of the final Application for Payment, indicate in writing the ENGINEER's recommendation of payment and present the Application to the OWNER for payment.
- B. After acceptance of the WORK by the OWNER's governing body, the OWNER will make final payment to the CONTRACTOR of the amount remaining after deducting all prior payments and all amounts to be kept or retained under the provisions of the Contract Documents, including the following items:
1. Liquidated damages, as applicable.
  2. Two times the value of outstanding items of correction work or punch list items yet uncompleted or uncorrected, as applicable. All such work shall be completed or corrected to the satisfaction of the OWNER within the time stated on the Notice of Completion, otherwise the CONTRACTOR does hereby waive any and all claims to all monies withheld by the OWNER to cover the value of all such uncompleted or uncorrected items.
- 14.10 RELEASE OF RETAINAGE AND OTHER DEDUCTIONS

## SECTION 00700 - GENERAL CONDITIONS

- A. After executing the necessary documents to initiate the lien period, and not more than 45 days thereafter (based on a 30-day lien filing period and 15-day processing time), the OWNER will release to the CONTRACTOR the retainage funds withheld pursuant to the Agreement, less any deductions to cover pending claims against the OWNER pursuant to Paragraph 14.5B.
- B. After filing of the necessary documents to initiate the lien period, the CONTRACTOR shall have 30 days to complete any outstanding items of correction work remaining to be completed or corrected as listed on a final punch list made a part of the Notice of Completion. Upon expiration of the 45 days, referred to in Paragraph 14.10A, the amounts withheld pursuant to the provisions of Paragraph 14.9B herein, for all remaining work items will be returned to the CONTRACTOR; provided, that said work has been completed or corrected to the satisfaction of the OWNER within said 30 days. Otherwise, the CONTRACTOR does hereby waive any and all claims for all monies withheld by the OWNER under the Contract to cover 2 times the value of such remaining uncompleted or uncorrected items.
- 14.11 CONTRACTOR'S CONTINUING OBLIGATION. The CONTRACTOR's obligation to perform and complete the WORK in accordance with the Contract Documents shall be absolute. Neither recommendation of any progress or final payment by the ENGINEER, nor the issuance of a Notice of Completion, nor any payment by the OWNER to the CONTRACTOR under the Contract Documents, nor any use or occupancy of the WORK or any part thereof by the OWNER, nor any act of acceptance by the OWNER nor any failure to do so, nor any review of a Shop Drawing or sample submittal, will constitute an acceptance of work not in accordance with the Contract Documents or a release of the CONTRACTOR's obligation to perform the WORK in accordance with the Contract Documents.
- 14.12 FINAL PAYMENT TERMINATES LIABILITY OF OWNER. Final payment is defined as the last progress payment made to the CONTRACTOR for earned funds, less monies withheld as applicable, pursuant to Paragraph 14.10A. The acceptance by the CONTRACTOR of the final payment referred to in Paragraph 14.9 herein, shall be a release of the OWNER and its agents from all claims of liability to the CONTRACTOR for anything done or furnished for, or relating to, the WORK or for any act of neglect of the OWNER or of any person relating to or affecting the WORK, except demands against the OWNER for the remainder, if any, of the amounts kept or retained under the provisions of Paragraph 14.9 herein; and excepting pending, unresolved claims filed prior to the date of the Notice of Completion.

## ARTICLE 15 SUSPENSION OF WORK AND TERMINATION

- 15.1 SUSPENSION OF WORK BY OWNER. The OWNER, acting through the ENGINEER, may, at any time and without cause, suspend the WORK or any portion thereof for a period of not more than 90 days by notice in writing to the CONTRACTOR. The CONTRACTOR shall resume the WORK on receipt from the ENGINEER of a notice of resumption of work. The CONTRACTOR shall be allowed an increase in the Contract Price or an extension of the Contract Time, or both, directly attributable to any suspension if the CONTRACTOR makes an approved claim therefor as provided in Articles 11 and 12.
- 15.2 TERMINATION OF AGREEMENT BY OWNER (CONTRACTOR DEFAULT)
- A. In the event of default by the CONTRACTOR, the OWNER may give 10 days written notice to the CONTRACTOR of OWNER's intent to terminate the Agreement and



## SECTION 00700 - GENERAL CONDITIONS

provide the CONTRACTOR an opportunity to remedy the conditions constituting the default. It shall be considered a default by the CONTRACTOR whenever CONTRACTOR shall: (1) declare bankruptcy, become insolvent, or assign its assets for the benefit of its creditors; (2) fail to provide materials or quality of work meeting the requirements of the Contract Documents; (3) disregard or violate provisions of the Contract Documents or ENGINEER's instructions; (4) fail to prosecute the WORK according to the approved progress schedule; or, (5) fail to provide a qualified superintendent, competent workers, or materials or equipment meeting the requirements of the Contract Documents; or 5) breach any of the material terms of the Agreement or the Contract documents. If the CONTRACTOR fails to remedy the conditions constituting default within the time allowed, the OWNER may then issue the Notice of Termination.

- B. In the event the Agreement is terminated in accordance with Paragraph 15.2A, herein, the OWNER may take possession of the WORK and may complete the WORK by whatever method or means the OWNER may select. The cost of completing the WORK shall be deducted from the balance which would have been due the CONTRACTOR had the Agreement not been terminated and the WORK completed in accordance with the Contract Documents. If such cost exceeds the balance which would have been due, the CONTRACTOR shall pay the excess amount to the OWNER. If such cost is less than the balance which would have been due, the CONTRACTOR shall not have claim to the difference.

15.3 TERMINATION OF AGREEMENT BY OWNER (FOR CONVENIENCE). The OWNER may terminate the Agreement at any time in its sole discretion in the best interests of the City and Borough of Wrangell. In such a case, the CONTRACTOR shall have no claims against the OWNER except: (1) for the value of work performed up to the date the Agreement is terminated, which shall be based on the CONTRACTOR'S bid price for all units of work performed and in no circumstances shall exceed the bid price for each unit of work actually performed; and, (2) for the cost of materials and equipment on hand, in transit, or on definite commitment, as of the date the Agreement is terminated which would be needed in the WORK and which meet the requirements of the Contract Documents. The value of work performed and the cost of materials and equipment delivered to the site, as mentioned above, shall be determined by the ENGINEER in accordance with the procedure prescribed for the making of the final application for payment and payment under Paragraphs 14.8 and 14.9.

15.4 TERMINATION OF AGREEMENT BY CONTRACTOR. The CONTRACTOR may terminate the Agreement upon 10 days written notice to the OWNER, whenever: 1) the WORK has been suspended under the provisions of Paragraph 15.1, herein, for more than 90 consecutive days through no fault or negligence of the CONTRACTOR, and notice to resume work or to terminate the Agreement has not been received from the OWNER within this time period; or, 2) the OWNER should fail to pay the CONTRACTOR any monies due him as approved for payment by the ENGINEER in accordance with the terms of the Contract Documents and within 60 days after presentation to the OWNER by the CONTRACTOR of a request therefor, unless within the 10-day period the OWNER shall have remedied the condition upon which the payment delay was based. In the event of such termination, the CONTRACTOR shall have no claims against the OWNER except for those claims specifically enumerated in Paragraph 15.3, herein, and as determined in accordance with the requirements of that paragraph.

## ARTICLE 16 MISCELLANEOUS

## SECTION 00700 - GENERAL CONDITIONS

- 16.1 GIVING NOTICE. Whenever any provision of the Contract Documents requires the giving of written notice, it will be deemed to have been validly given if delivered in person to the individual or to a member of the firm or to an officer of the corporation for whom it is intended, or if delivered at or sent by registered or certified mail, postage prepaid, to the last business address known to the giver of the notice. E-mail shall not constitute written notice.
- 16.2 RIGHTS IN AND USE OF MATERIALS FOUND ON THE WORK
- A. The CONTRACTOR may use on the Project, with ENGINEER's approval, such stone, gravel, sand, or other material determined suitable by the ENGINEER, as may be found in the excavation. The CONTRACTOR will be paid for the excavation of such material at the corresponding contract unit price. No additional payment will be made for utilizing the material from excavation as borrow or select borrow.
  - B. The CONTRACTOR shall replace, at its own expense, with other acceptable material, all of that portion of the excavated material so removed and used which was needed for use on the project. No charge for the materials so used will be made against the CONTRACTOR except that the CONTRACTOR shall be responsible for payment of any royalties required.
  - C. The CONTRACTOR shall not excavate or remove any material from within the Project location which is not within the grading limits, as indicated by the slope and grade lines, without written authorization from the ENGINEER.
  - D. In the event the CONTRACTOR has processed materials from OWNER-furnished sources in excess of the quantities required for performance of this contract, including any waste material produced as a by-product, the OWNER may retain possession of such materials without obligation to reimburse the CONTRACTOR for the cost of their production. When such materials are in a stockpile, the ENGINEER may require: That it remain in stockpile; the CONTRACTOR level such stockpile(s); or that the CONTRACTOR remove such materials and restore the premises to a satisfactory condition at the CONTRACTOR's expense. This provision shall not preclude the OWNER from arranging with the CONTRACTOR to produce material over and above the contract needs, payment for which shall be by written agreement between the OWNER and the CONTRACTOR.
  - E. Unless otherwise provided, the material from any existing old structure may be used temporarily by the CONTRACTOR in the erection of the new structure. Such material shall not be cut or otherwise damaged except with the approval of the ENGINEER.
- 16.3 RIGHT TO AUDIT. If the CONTRACTOR submits a claim to the OWNER for additional compensation, the OWNER shall have the right, as a condition to considering the claim, and as a basis for evaluation of the claim, and until the claim has been settled, to audit the CONTRACTOR's books to the extent they are relevant. This right shall include the right to examine books, records, documents, and other evidence and accounting procedures and practices, sufficient to discover and verify all direct and indirect costs of whatever nature claimed to have been incurred or anticipated to be incurred and for which the claim has been submitted. The right to audit shall include the right to inspect the CONTRACTOR's plants, or such parts thereof, as may be or have been engaged in the performance of the WORK. The CONTRACTOR further agrees that the right to audit encompasses all subcontracts and is binding upon Subcontractors. The rights to examine and inspect herein provided for shall be exercisable through such

## SECTION 00700 - GENERAL CONDITIONS

representatives as the OWNER deems desirable during the CONTRACTOR's normal business hours at the office of the CONTRACTOR. The CONTRACTOR shall make available to the OWNER for auditing, all relevant accounting records and documents, and other financial data, and upon request, shall submit true copies of requested records to the OWNER.

- 16.4 ARCHAEOLOGICAL OR HISTORICAL DISCOVERIES. When the CONTRACTOR's operation encounters prehistoric artifacts, burials, remains of dwelling sites, paleontological remains, such as shell heaps, land or sea mammal bones or tusks, or other items of historical significance, the CONTRACTOR shall cease operations immediately and notify the ENGINEER. No artifacts or specimens shall be further disturbed or removed from the ground and no further operations shall be performed at the site until so directed. Should the ENGINEER order suspension of the CONTRACTOR's operations in order to protect an archaeological or historical finding, or order the CONTRACTOR to perform extra work, such order(s) shall be covered by an appropriate contract change document.
- 16.5 CONSTRUCTION OVER OR ADJACENT TO NAVIGABLE WATERS. All work over, on, or adjacent to navigable waters shall be so conducted that free navigation of the waterways will not be interfered with and the existing navigable depths will not be impaired, except as allowed by permit issued the U.S. Coast Guard and/or the U.S. Army Corps of Engineers, as applicable.
- 16.6 GRATUITY AND CONFLICT OF INTEREST. The CONTRACTOR agrees to not extend any loan, gratuity, or gift of money of any form whatsoever to any employee or elected official of the OWNER.

### 16.7 SUITS OF LAW CONCERNING THE WORK

A. The Superior Court for the State of Alaska, First Judicial District at Wrangell, Alaska, shall be the exclusive jurisdiction and venue for any action of any kind an any nature arising out of or relating to this Agreement and all Contract documents or for any action of any kind and any nature arising out of or related to the performance of non-performance of the CONTRATOR, and CONTRACTOR'S employees, subcontractors, consultants and representatives.

- B. If one of the questions at issue is the satisfactory performance of the work by the CONTRACTOR and should the appropriate court of law judge the work of the CONTRACTOR to be unsatisfactory, then the CONTRACTOR (or the CONTRACTOR's surety) shall reimburse the OWNER for all legal and all other expenses (as may be allowed and set by the court) incurred by the OWNER because of the suit of the law and, further, it is agreed that the OWNER may deduct such expense from any sum or sums then, or any that become due the CONTRACTOR under the contract.

### 16.8 CERTIFIED PAYROLLS

- A. All CONTRACTORs or Subcontractor who perform work on a public construction contract for the OWNER shall file a certified payroll with the Alaska Department of Labor before Friday of each week that covers the preceding week (Section 14-2-4 ACLA 1949; am Section 4 ch 142 SLA 1972).

## SECTION 00700 - GENERAL CONDITIONS

- B. In lieu of submitting the State payroll form, the CONTRACTOR's standard payroll form may be submitted, provided it contains the information required by AS 36.05.040 and a statement that the CONTRACTOR is complying with AS 36.10.010.
- C. A CONTRACTOR or Subcontractor, who performs work on public construction in the State, as defined by AS 36.95.010(3), shall pay not less than the current prevailing rate of wages as issued by the Alaska Department of Labor before the end of the pay period. (AS 36.05.010).

### 16.9 PREVAILING WAGE RATES

- A. Wage rates for Laborers and Mechanics on Public Contracts, AS 36.05.070. The CONTRACTOR, or Subcontractors, shall pay all employees unconditionally and not less than once a week. Wages may not be less than those stated in Paragraph 16.8C, regardless of the contractual relationship between the CONTRACTOR or Subcontractors and laborers, mechanics, or field surveyors. The scale of wages to be paid shall be posted by the CONTRACTOR in a prominent, easily accessible place at the site of the WORK.
- B. Failure to Pay Agreed Wages, AS 36.05.080. If it is found that a laborer, mechanic, or field surveyor employed by the CONTRACTOR or Subcontractor has been, or is being, paid a rate or wages less than the established rate, the OWNER may, by written notice, terminate the CONTRACTOR or Subcontractors right to proceed with the work. The OWNER may prosecute the work to completion by contract or otherwise, and the CONTRACTOR and sureties will be held liable to the OWNER for excess costs for completing the WORK. (Section 2 ch 52 SLA 1959).
- F. Listing CONTRACTOR's Who Violate Contracts, AS 36.05.090. In addition, a list giving the names of persons who have disregarded the rights of their employees shall be distributed to all departments of State government and all political subdivisions. No person appearing on this list, and no firm, corporation, partnership or association in which the person has an interest, may work as a CONTRACTOR or Subcontractor on a public construction contract for the State, or a political subdivision of the state, until three years after the date of publication of the list. (Section 3 ch 52 SLA 1959; am Section 9 ch 142 SLA).

16.10 EMPLOYMENT REFERENCE. Workers employed in the execution of the contract by the CONTRACTOR or by any Subcontractor under this contract shall not be required or permitted to labor more than 8 hours a day or 40 hours per week in violation of the provisions of the Alaska Wage and Hour Act, Section 23.10.060.

### 16.11 COST REDUCTION INCENTIVE

- A. At any time within 45 days after the date of the Notice of Award, the CONTRACTOR may submit to the ENGINEER in writing, proposals for modifying the plans, specifications, or other requirements of this contract for the sole purpose of reducing the total cost of construction. The cost reduction proposal shall not impair in any manner the essential functions or characteristics of the project, including but not limited to, service life, economy of operation, ease of maintenance, desired appearance or design and safety standards.
- B. The cost reduction proposal shall contain the following information:

## SECTION 00700 - GENERAL CONDITIONS

1. Description of both the existing contract requirements for performing the WORK and the proposed changes.
  2. An itemization of the contract requirements that must be changed if the proposal is adopted.
  3. A detailed estimate of the time required and the cost of performing the WORK under both the existing contract and the proposed change.
  4. A statement of the date by which the CONTRACTOR must receive the decision from the OWNER on the cost reduction proposal.
  5. The contract items of WORK affected by the proposed changes including any quantity variations.
  6. A description and estimate of costs the OWNER may incur in implementing the proposed changes, such as test and evaluation and operating and support costs.
  7. A prediction of any effects the proposed change would have on future operations and maintenance costs to the OWNER.
- C. The provisions of this section shall not be construed to require the OWNER to consider any cost reduction proposal which may be submitted; nor will the OWNER be liable to the CONTRACTOR for failure to accept or act upon any cost reduction proposal submitted, or for delays to the work attributable to the consideration or implementation of any such proposal.
- D. If a cost reduction proposal is similar to a change in the plans or specifications for the project under consideration by the OWNER at the time the proposal is submitted, the OWNER will not accept such proposal and reserves the right to make such changes without compensation to the CONTRACTOR under the provisions of this section.
- E. The CONTRACTOR shall continue to perform the work in accordance with the requirements of the contract until an executed Change Order incorporating the cost reduction proposal has been issued. If any executed Change Order has not been issued by the date upon which the CONTRACTOR's cost reduction proposal specifies that a decision should be made by the OWNER, in writing, the cost reduction proposal shall be considered rejected.
- F. The OWNER shall be the sole judge of the acceptability of a cost reduction proposal and of the estimated net savings in Contract Time and construction costs resulting from the adoption of all or any part of such proposal. Should the CONTRACTOR disagree with OWNER's decision on the cost reduction proposal, there is no further consideration. The OWNER reserves the right to make final determination.
- G. If the CONTRACTOR's cost reduction proposal is accepted in whole or in part, such acceptance will be made by a contract Change Order, which specifically states that the change is executed pursuant to this cost reduction proposal section. Such Change Order shall incorporate the changes in the plans and specifications which are necessary to permit the cost reduction proposal or such part of it as has been accepted to be put into effect and shall include any conditions upon which the OWNER's approval is based, if such approval is conditional. The Change Order shall also describe the estimated net savings in the cost of performing the work attributable to the cost reduction proposal, and shall further provide that the contract cost be adjusted by crediting the OWNER with the estimated net savings amount.

## SECTION 00700 - GENERAL CONDITIONS

- H. Acceptance of the cost reduction proposal and performance of the work does not extend the time of completion of the contract, unless specifically provided in the Change Order authorizing the use of the submitted proposal. Should the adoption of the cost reduction proposal result in a Contract Time savings, the total Contract Time shall be reduced by an amount equal to the time savings realized.
- I. The amount specified to the CONTRACTOR in the Change Order accepted in the cost reduction proposal shall constitute full compensation for the performance of WORK. No claims for additional costs as a result of the changes specified in the cost reduction proposal shall be allowed.
- J. The OWNER reserves the right to adopt and utilize any approved cost reduction proposal for general use on any contract administered when it is determined suitable for such application. Cost reduction proposals identical, similar, or previously submitted will not be accepted for consideration if acceptance and compensation has previously been approved. The OWNER reserves the right to use all or part of any cost reduction proposal without obligation or compensation of any kind to the CONTRACTOR.
- K. The CONTRACTOR shall bear the costs, if any, to revise all bonds and insurance requirements for the project, to include the cost reduction WORK.

**END OF SECTION**

**SECTION 00800 - SUPPLEMENTARY GENERAL CONDITIONS**

**GENERAL.** These Supplementary General Conditions make additions, deletions, or revisions to the General Conditions as indicated herein. All provisions which are not so added, deleted, or revised remain in full force and effect. Terms used in these Supplementary General Conditions which are defined in the General Conditions have the meanings assigned to them in the General Conditions.

**SGC 4.2 PHYSICAL CONDITIONS - SUBSURFACE AND EXISTING STRUCTURES.** *Add* the following:

- C. In the preparation of the Contract Documents, the Engineer of Record has relied upon:
  - 1. Field measurements and visual inspection of the existing structures and surface conditions.

**SGC 5.2 INSURANCE AMOUNTS.** The limits of liability for the insurance required by Paragraph 5.2 of the General Conditions shall provide coverage for not less than the following amounts or greater where required by Laws and Regulations:

- A. Workers' Compensation: (under Paragraph 5.2, C.1 of the General Conditions) as in accordance with AS 23.30.045:
  - 1. State: Statutory
  - 2. Applicable Federal (e.g., Longshore): Statutory

Note: If the WORK called for in the Contract Documents involves work in or on any navigable waters, the CONTRACTOR shall provide Workers' Compensation coverage which shall include coverage under the Longshore and Harbor Workers' Compensation Act, the Jones Act, and any other coverage required under Federal or State laws pertaining to workers in or on navigable waters.

- 3. Employers Liability
  - Bodily Injury by Accident: \$100,000.00 Each Accident
  - Bodily Injury by Disease: \$100,000.00 Each Employee
  - Bodily Injury by Disease: \$500,000.00 Policy Limit
  - a. CONTRACTOR agrees to waive all rights of subrogation against the OWNER and ENGINEER for work performed under Contract.
  - b. If CONTRACTOR directly utilizes labor outside of the State of Alaska in the prosecution of the WORK, "Other States" endorsement shall be required as a condition of the Contract.

- B. Commercial General Liability: (under Paragraph 5.2, C.2 of the General Conditions):
  - 1. Combined Single Limit
    - a. General Policy \$2,000,000.00 Each Occurrence  
\$3,000,000.00 Annual Aggregate
    - b. Products/Completed Operations \$2,000,000.00 Each Occurrence  
\$3,000,000.00 Annual Aggregate
    - c. Personal Injury \$2,000,000.00 Each Occurrence

**SECTION 00800 - SUPPLEMENTARY GENERAL CONDITIONS**

- C. Commercial Automobile Liability: (under Paragraph 5.2, C.3 of the General Conditions) including Owned, Hired, and Non-Owned Vehicles:

Combined Single Limit, Bodily Injury and Property Damage \$1,000,000.00

- D. Policies shall also specify insurance provided by CONTRACTOR will be considered primary and not contributory to any other insurance available to the OWNER or the ENGINEER.
- E. All policies will provide for 30 Days written notice prior to any cancellation or nonrenewal of insurance policies required under Contract except in the event of no-payment of premium where 10 Days is permissible.
- F. The OWNER and the ENGINEER shall be named as an "Additional Insured" under all liability coverages listed in this Section, except for workers' compensation insurance. CONTRACTOR shall furnish OWNER a certificate from the insurer showing the OWNER as an Additional Insured within ten (10) days of the CONTRACTOR receiving the Notice to Proceed. Failure of the CONTRACTOR to fully and strictly comply with this Section shall constitute a default and a material breach of the Agreement and Contract documents.

**SGC 14.9 FINAL PAYMENT AND ACCEPTANCE.** *Add* the following paragraph:

- B. Prior to the final payment the CONTRACTOR shall contact the Alaska Department of Labor (ADOL) and provide the OWNER with clearance from the ADOL for the CONTRACTOR and all Subcontractors that have worked on the Project. This clearance shall indicate that all Employment Security Taxes have been paid. A sample letter for this purpose is provided at the end of this section.

**END OF SECTION**



**SECTION 00830 - ALASKA LABOR STANDARDS, REPORTING, AND  
PREVAILING WAGE RATE DETERMINATION**

State of Alaska, Department of Labor, Laborers' and Mechanics' Minimum Rates of Pay, AS 36.05.010 and AS 36.05.050, Wage and Hour Administration Pamphlet No. 600, the latest edition at the time of bid opening, published by the State of Alaska, Department of Labor inclusive, are made a part of this contract by reference.

The CONTRACTOR is responsible for contacting the Alaska Department of Labor to determine compliance with current regulations.

Required Reporting During Contract (to be provided by every CONTRACTOR and Subcontractor):

- A. **Certified Payrolls must be submitted every week, for the previous week. Before each Friday,** each CONTRACTOR and Subcontractor must file Certified Payrolls with Statements of Compliance for the previous week. If there was no activity for that pay period, indicate "No Activity." Indicate "Start" on your first payroll, and "Final" on your last payroll for this Project. Send to:

<i><b>Wage and Hour Section</b></i> Labor Law Compliance Division Alaska Department of Labor P.O. Box 020630 Juneau, AK 99802-0630 (907) 465-4842	and	<i><b>Project Manager</b></i> City & Borough of Wrangell P.O. Box 531 Wrangell, AK 99929 (907) 874-2381
--	-----	---

- B. **Within 10 Days of "Notice of Award/Notice to Proceed"** make a list of **all** Subcontractors. Include their name, address, phone, estimated subcontract amount, and estimated start and finish dates. Send to:

<i><b>Borough Clerk</b></i> City & Borough of Wrangell P.O. Box 531 Wrangell, AK 99929 (907) 874-2381	and	<i><b>Wage and Hour Section</b></i> Labor Law Compliance Division Alaska Department of Labor P.O. Box 020630 Juneau, AK 99802-0630 (907) 465-4839/4842
---	-----	---

- C. As part of the **final payment request package**:

A completed Compliance Certificate and Release form (provided in Section 01700 - Project Closeout) from every CONTRACTOR and Subcontractor.

A final Subcontractor list complete with final subcontract amounts and including all equipment rentals (with operators).

A Completion of Public Project form from the Alaska Department of Labor.

**END OF SECTION**

## SECTION 01010 - SUMMARY OF WORK

### PART 1 – GENERAL

#### 1.1 GENERAL

- A. The WORK to be performed under this contract shall consist of furnishing all plant, tools, equipment, materials, supplies, manufactured articles, labor, transportation and services, including fuel, power, water, and essential communications, and performing all WORK, or other operations required for the fulfillment of the contract in strict accordance with the Contract Documents. The WORK shall be complete, and all work, materials, and services not expressly indicated or called for in the Contract Documents which may be necessary for the complete and proper construction of the WORK in good faith shall be provided by the CONTRACTOR as though originally so indicated, at no increase in cost to the OWNER.

#### 1.2 WORK COVERED BY CONTRACT DOCUMENTS

- A. WORK consists of various quantities of mobilization, electrical service equipment, underground electrical systems, cabling, wiring, panelboard, and other improvements necessary to provide for a backup power generator connection.

#### 1.3 SITE OF THE WORK

- A. The WORK is located at the Wrangell Airport, Airport Loop Road, in Wrangell, Alaska.

#### 1.4 BEGINNING AND COMPLETION OF THE WORK

- A. Time is the essence of the contract. All WORK shall be completed in accordance with the following schedule:

<u>WORK DESCRIPTION</u>	<u>COMPLETION DATE</u>
Substantial Completion	September 30, 2024
Final Completion	October 15, 2024

#### 1.5 CONTRACT METHOD

- A. The WORK hereunder will be constructed under a lump sum price contract.

#### 1.6 WORK BY OTHERS

- A. The CONTRACTOR's attention is directed to the fact that work may be conducted at the site by other contractors during the performance of the WORK under this Contract. The CONTRACTOR shall conduct its operations so as to cause a minimum of interference with the work of such other contractors, and shall cooperate fully with such contractors to provide continued safe access to their respective portions of the site, as required to perform work under their respective contracts.
- B. Interference With Work On Utilities: The CONTRACTOR shall cooperate fully with all utility forces of the OWNER or forces of other public or private agencies engaged in the

## SECTION 01010 - SUMMARY OF WORK

relocation, altering, or otherwise rearranging of any facilities which interfere with the progress of the WORK, and shall schedule the WORK so as to minimize interference with said relocation, altering, or other rearranging of facilities.

### 1.8 CONTRACTOR USE OF PROJECT SITE

- A. The CONTRACTOR's use of the Project site shall be limited to its construction operations, including on-site storage of materials.

### 1.9 OWNER USE OF THE PROJECT SITE

- A. The OWNER may utilize all or part of the existing site during the entire period of construction for the conduct of the OWNER's normal operations. The CONTRACTOR shall cooperate and coordinate with the ENGINEER to facilitate the OWNER's operations and to minimize interference with the CONTRACTOR's operations at the same time. In any event, the OWNER shall be allowed access to the Project site during the period of construction.

### 1.10 PROJECT MEETINGS

#### A. Pre-Construction Conference

1. Prior to the commencement of WORK at the site, a Pre-Construction Conference will be held at a mutually agreed time and place which shall be attended by the CONTRACTOR's Project manager, its superintendent, and its Subcontractors as the CONTRACTOR deems appropriate. Other attendants will be:
  - a. ENGINEER and the Inspector.
  - b. Representatives of OWNER.
  - c. Governmental representatives as appropriate.
  - d. Others as requested by CONTRACTOR, OWNER, or ENGINEER.
2. Unless previously submitted to the ENGINEER, the CONTRACTOR shall bring one copy each of the following:
  - a. Plan of Operation.
  - b. Project Overview Bar Chart Schedule.
  - c. Procurement schedule of major equipment and materials and items requiring long lead time.
  - d. Shop Drawing/Sample/Substitute or "Or Equal" submittal schedule.
  - e. Name and telephone number of CONTRACTOR's Project Supervisor.
  - f. Schedule of Values
3. The purpose of the Pre-Construction Conference is to designate responsible personnel and establish a working relationship. Matters requiring coordination will be discussed and procedures for handling such matters established. The complete agenda will be furnished to the CONTRACTOR prior to the meeting date.

## SECTION 01010 - SUMMARY OF WORK

The CONTRACTOR should be prepared to discuss all the items listed below:

- a. Status of CONTRACTOR's insurance and bonds.
- b. CONTRACTOR's tentative schedules.
- c. Transmittal, review, and distribution of CONTRACTOR's submittals.
- d. Processing applications for payment.
- e. Maintaining record documents.
- f. Critical WORK sequencing.
- g. Field decisions and Change Orders.
- h. Use of Project site, office and storage areas, security, housekeeping, and OWNER's needs.
- i. Traffic control and access
- j. Major equipment deliveries and priorities.
- k. CONTRACTOR's assignments for safety and first aid.

4. The OWNER will preside at the Pre-Construction Conference and will arrange for keeping and distributing the minutes to all persons in attendance.
5. The CONTRACTOR and its Subcontractors should plan on the conference taking no less than 2 hours. The items listed in paragraph 3 will be covered as well as reviewing the plans and specifications, in extensive detail, with the ENGINEER and the OWNER.

### B. Progress Meetings

1. The CONTRACTOR shall schedule and hold weekly progress meetings and at other times as requested by the ENGINEER, or as required by progress of the WORK. The CONTRACTOR, ENGINEER, and all subcontractors active on the site must attend each meeting. CONTRACTOR may at its discretion request attendance by representatives of its suppliers, manufacturers, and other subcontractors.
2. The ENGINEER shall preside at the meetings and will arrange for keeping and distributing the minutes. The purpose of the meetings will be to review the progress of the WORK, maintain coordination of efforts, discuss changes in scheduling, and resolve other problems which may develop. During each meeting, the CONTRACTOR is required to present any issues which may impact its work, with a view to resolve these issues expeditiously.

1.11 DEFINITIONS APPLICABLE TO TECHNICAL SPECIFICATIONS. The following words have the meaning defined in the Technical Portions of the WORK:

**Furnish** - means to supply and deliver to the site, to unload and unpack ready for assembly, installation, testing, and start-up.

**Indicated** - is a word used to direct the CONTRACTOR to information contained on the drawings or in the Specifications. Terms such as "shown," "noted," "scheduled," and "specified" also may be used to assist in locating information but no limitation of location is implied or intended.

## **SECTION 01010 - SUMMARY OF WORK**

**Install** - defines operations at the site including assembly, erection, placing, anchoring, applying, shaping to dimension, finishing, curing, protecting, and cleaning, ready for the OWNER's use.

**Installer** - a person or firm engaged by the CONTRACTOR or its subcontract or any subcontractor for the performance of installation, erection, or application work at the site. Installers must be expert in the operations they are engaged to perform.

**Provide** - is defined as furnish and install, ready for the intended use.

**PART 2 - PRODUCTS (Not Used)**

**PART 3 - EXECUTION (Not Used)**

**END OF SECTION**

## SECTION 01300 - CONTRACTOR SUBMITTALS

### PART 1 - GENERAL

#### 1.1 GENERAL

- A. Whenever submittals are required hereunder, all such submittals by the CONTRACTOR shall be submitted to the ENGINEER.
- B. Within 14 days after the date of commencement as stated in the Notice of Award/Notice to Proceed, the CONTRACTOR shall submit the following items to the ENGINEER for review:
  - 1. A Plan of Operation summarizing the methods and equipment to be used to complete the WORK.
  - 2. A Project Schedule as described in Section 1.7 of this specification.
  - 3. A Procurement Schedule outlining key milestones for procurement of major components of the WORK.
  - 4. A preliminary schedule of Shop Drawing, Sample and proposed Substitutes or “Or-Equal” submittals.
  - 5. A list of all permits and licenses the CONTRACTOR shall obtain indicating the agency required to grant the permit and the expected date of submittal for the permit and the required date for receipt of the permit.
  - 6. All required Material Safety Data Sheets.
  - 7. A staging and traffic maintenance plan, as required.
  - 8. A plan for temporary erosion control and pollution control, as required.
  - 9. A letter designating the CONTRACTOR’s Superintendent, defining that person’s responsibility and authority, and providing contact information and a specimen of his signature.
  - 10. A letter designating the CONTRACTOR’s safety representative and the person’s responsibility and authority, and providing contact information.

#### 1.2 SHOP DRAWING SUBMITTAL

- A. Wherever called for in the Contract Documents, or where required by the ENGINEER, the CONTRACTOR shall furnish to the ENGINEER, for review, 4 copies of each shop drawing submittal unless otherwise indicated. Electronic submittal transmission may be allowed if approved in advance by the ENGINEER. The term “ Shop Drawings” as used herein shall be understood to include detail design calculations, shop drawings, fabrication and installation drawings, erection drawings, lists, graphs, operating instructions, catalog sheets, data sheets, and similar items.
- B. All Shop Drawing Submittals shall be accompanied by the ENGINEER’s standard submittal transmittal form. The form may be obtained in quantity from the ENGINEER. Any submittal not accompanied by such a form, or where all applicable items on the form are not completed, will be returned for resubmittal.
- C. Normally, a separate transmittal form shall be used for each specific item or class of material or equipment for which a submittal is required. Transmittal of a submittal of various items using a single transmittal form will be permitted only when the items taken together constitute a manufacturer’s “package” or are so functionally related that expediency indicates review of the group or package as a whole. A multiple-page

## SECTION 01300 - CONTRACTOR SUBMITTALS

submittal shall be collated into sets, and each set shall be stapled or bound, as appropriate, prior to transmittal to the ENGINEER.

- D. Except as otherwise provided herein, the ENGINEER will return prints of each submittal to the CONTRACTOR with its comments noted thereon, within 14 calendar days following their receipt by the ENGINEER. It is considered reasonable that the CONTRACTOR shall make a complete and acceptable submittal to the ENGINEER by the second submission of a submittal item. The OWNER reserves the right to withhold monies due to the CONTRACTOR to cover additional costs of the ENGINEER review beyond the second submittal. The ENGINEER's maximum review period for each submittal including all re-submittals will be 7 days per submission. In other words, for a submittal that requires two re-submittals before it is complete, the maximum review period for that submittal could be 28 Days.
- E. If 3 copies (or a single electronic transmission) of a submittal are returned to the CONTRACTOR marked "NO EXCEPTIONS TAKEN," formal revision and resubmission of said submittal will not be required.
- F. If 3 copies (or a single electronic transmission) of a submittal are returned to the CONTRACTOR marked "MAKE CORRECTIONS NOTED," formal revision and resubmission of said submittal is not required.
- G. If one copy (or a single electronic transmission) of the submittal is returned to the CONTRACTOR marked "AMEND-RESUBMIT," the CONTRACTOR shall revise said submittal and shall resubmit the required number of copies of said revised submittal to the ENGINEER.
- H. If one copy (or a single electronic transmission) of the submittal is returned to the CONTRACTOR marked "REJECTED-RESUBMIT," the CONTRACTOR shall revise said submittal and shall resubmit the required number of copies of said revised submittal to the ENGINEER.
- I. Fabrication of an item may be commenced only after the ENGINEER has reviewed the pertinent submittal and returned copies to the CONTRACTOR marked either "NO EXCEPTIONS TAKEN" or "MAKE CORRECTIONS NOTED." Corrections indicated on submittal shall be considered as changes necessary to meet the requirements of the Contract Documents and shall not be taken as the basis for changes to the Contract requirements. Only a change order can alter the contract price, time, or requirements.
- J. All CONTRACTOR shop drawing submittals shall be carefully reviewed by an authorized representative of the CONTRACTOR, prior to submission to the ENGINEER. Each submittal shall be dated, signed, and certified by the CONTRACTOR, as being correct and in strict conformance with the Contract Documents. In the case of shop drawings, each sheet shall be so dated, signed, and certified. No consideration for review by the ENGINEER of any CONTRACTOR submittal will be made for any items which have not been so certified by the CONTRACTOR. All non-certified submittals will be returned to the CONTRACTOR without action taken by the ENGINEER, and any delays caused thereby shall be the total responsibility of the CONTRACTOR.

## SECTION 01300 - CONTRACTOR SUBMITTALS

- K. The ENGINEER's review of CONTRACTOR shop drawing submittals shall not relieve the CONTRACTOR of the entire responsibility for the correctness of details and dimensions. The CONTRACTOR shall assume all responsibility and risk for any misfits due to any errors in CONTRACTOR submittals. The CONTRACTOR shall be responsible for the dimensions and the design of adequate connections and details.

### 1.3 SAMPLES SUBMITTAL

- A. Whenever in the Specifications samples are required, the CONTRACTOR shall submit not less than 3 samples of each item or material to the ENGINEER for acceptance at no additional cost to the OWNER.
- B. Samples, as required herein, shall be submitted for acceptance a minimum of 14 days prior to ordering such material for delivery to the job site, and shall be submitted in an orderly sequence so that dependent materials or equipment can be assembled and reviewed without causing delays in the WORK.
- C. All samples shall be individually and indelibly labeled or tagged, indicating thereon all specified physical characteristics and Supplier's names for identification and submitted to the ENGINEER for acceptance. Upon receiving acceptance of the ENGINEER, one set of the samples will be stamped and dated by the ENGINEER and returned to the CONTRACTOR, and one set of samples will be retained by the ENGINEER, and one set of samples shall remain at the job site until completion of the WORK.
- D. Unless clearly stated otherwise, it is assumed that all colors and textures of specified items presented in sample submittal are from the manufacturer's standard colors and standard materials, products, or equipment lines. If the samples represent non-standard colors, materials, products or equipment lines, and their selection will require an increase in contract time or price, the CONTRACTOR will clearly indicate this on the transmittal page of the submittal.

### 1.4 TECHNICAL MANUAL SUBMITTAL

- A. The CONTRACTOR shall include in the technical manuals for each item of mechanical, electrical, and instrumentation equipment, the following:
  - 1. Complete operating instructions, including location of controls, special tools or other equipment required, related instrumentation, and other equipment needed for operation.
  - 2. Lubrication schedules, including the lubricant SAE grade and type, temperature range of lubricants, and including frequency of required lubrication.
  - 3. Preventive maintenance procedures and schedules.
  - 4. Parts lists, by generic title and identification number, complete, with exploded views of each assembly.
  - 5. Disassembly and reassembly instructions.
  - 6. Name and location of nearest supplier and spare parts warehouse.
  - 7. Recommended troubleshooting and startup procedures.
  - 8. Reproducible prints of the record drawings, including diagrams and schematics, as required under the electrical and instrumentation portions of these Specifications.



## SECTION 01300 - CONTRACTOR SUBMITTALS

9. Tabulation of proper settings for all pressure relief valves, (low/high) pressure switches and other related equipment protection devices.
  10. Detailed test procedures to determine performance efficiency of equipment.
  11. List of all electrical relay settings including alarm and contact settings.
- B. The CONTRACTOR shall furnish to the ENGINEER 5 identical sets of technical manuals. Each set shall consist of one or more volumes, each of which shall be bound in a standard size, 3-ring, loose-leaf vinyl plastic hard cover binder suitable for bookshelf storage. Binder ring size shall not exceed 2.5 inches. A table of contents shall be provided which indicates all equipment in the technical manuals.
- C. All technical manuals shall be submitted in final form to the ENGINEER not later than the 75 percent of construction completion date. All discrepancies found by the ENGINEER in the technical manuals shall be corrected by the CONTRACTOR within 30 days from the date of written notification by the ENGINEER.
- D. Incomplete or unacceptable technical manuals at the 75 percent construction completion point shall constitute sufficient justification to withhold payment for work completed beyond that period in accordance with Paragraph "Technical Manual Submittal" of Section 01700 - Project Closeout.

### 1.5 SPARE PARTS LIST SUBMITTAL

- A. The CONTRACTOR shall furnish to the ENGINEER 5 identical sets of spare parts information for all mechanical, electrical, and instrumentation equipment. The spare parts list shall include the current list price of each spare part. The spare parts list shall be limited to those spare parts which each manufacturer recommends be maintained by the OWNER in inventory at the plant site. Each manufacturer or supplier shall indicate the name, address, and telephone number of its nearest outlet of spare parts to facilitate the OWNER in ordering. The CONTRACTOR shall cross-reference all spare parts lists to the equipment numbers designated in the Contract Documents. The spare parts lists shall be bound in standard size, 3-ring, loose leaf, vinyl plastic hard cover binders suitable for bookshelf storage. Binder ring size shall not exceed 2.5 inches.

### 1.6 RECORD DRAWINGS SUBMITTALS

- A. The CONTRACTOR shall keep and maintain, at the job site, one record set of Drawings. On these, it shall mark all Project conditions, locations, configurations, and any other changes or deviations which may vary from the details represented on the original contract Drawings, including buried or concealed construction and utility features which are revealed during the course of construction. Special attention shall be given to recording the horizontal and vertical location of all buried utilities that differ from the locations indicated, or which were not indicated on the contract Drawings. Said record drawings shall be supplemented by any detailed sketches as necessary or directed to indicate, fully, the WORK as actually constructed. These master record drawings, of the CONTRACTOR's representation of as-built conditions, including all revisions made necessary by addenda, change orders, and the like shall be maintained up-to-date during the progress of the WORK.

## SECTION 01300 - CONTRACTOR SUBMITTALS

- B. In the case of those drawings which depict the detail requirement for equipment to be assembled and wired in the factory, such as motor control centers and the like, the record drawings shall be updated by indicating those portions which are superseded by Change Order Drawings or final Shop Drawings, and by including appropriate reference information describing the Change Orders by number and the Shop Drawings by manufacturer, drawing, and revision numbers.
- C. Record Drawings shall be accessible to the ENGINEER at all times during the construction period and shall be delivered to the ENGINEER on the 20<sup>th</sup> working day of every third month after the month in which the Notice to Proceed is given as well as upon completion of the WORK.
- D. Final payment will not be acted upon until the CONTRACTOR-prepared record drawings have been delivered to the ENGINEER.

### 1.7 PROGRESS SCHEDULES

- A. The progress schedule shall be in Bar Chart or Critical Path Method (CPM) form, as required by the ENGINEER.
- B. The progress schedule shall show the order in which the CONTRACTOR proposes to carry out the WORK and the contemplated date on which the CONTRACTOR and their subcontractors will start and finish each of the salient features of the work, including any scheduled periods of shutdown. The schedule shall also indicate any anticipated periods of multiple-shift work.
- C. Upon substantial changes to the CONTRACTOR's progress schedule of work or upon request of the ENGINEER, the CONTRACTOR shall submit a revised progress schedule(s) in the form required. Such revised schedule(s) shall conform with the Contract Time and take into account delays which may have been encountered in the performance of the WORK. In submitting a revised schedule, the CONTRACTOR shall state specifically the reason for the revision and the adjustments made in his schedule or methods of operation to ensure the completion of all the WORK within the Contract Time.

### 1.8 PROPOSED SUBSTITUTES OR "OR-EQUAL" ITEM SUBMITTAL

- A. Whenever materials or equipment are specified or described in the Contract Documents by using the name of a proprietary item or the name of a particular Supplier, the naming of the item is intended to establish the type, function, and quality required. If the name is followed by the words "or-equal" indicating that a substitution is permitted, materials or equipment of other suppliers may be accepted by the ENGINEER if sufficient information is submitted by the CONTRACTOR to allow the ENGINEER to determine that the material or equipment proposed is equivalent or equal to that named, subject to the following requirements:
  - 1. The burden of proof as to the type, function, and quality of any such substitute material or equipment shall be upon the CONTRACTOR.

## SECTION 01300 - CONTRACTOR SUBMITTALS

2. The ENGINEER will be the sole judge as to the type, function, and quality of any such substitute material or equipment and the ENGINEER's decision shall be final.
  3. The ENGINEER may require the CONTRACTOR, to furnish at the CONTRACTOR's expense, additional data about the proposed substitute.
  4. The OWNER may require the CONTRACTOR to furnish at the CONTRACTOR's expense a special performance guarantee or other surety with respect to any substitute.
  5. Acceptance by the ENGINEER of a substitute item proposed by the CONTRACTOR shall not relieve the CONTRACTOR of the responsibility for full compliance with the Contract documents and for adequacy of the substitute item.
  6. The CONTRACTOR shall be responsible for resultant changes and all additional costs which the accepted substitution requires in the CONTRACTOR's work, the work of its subcontractors and of other contractors, and shall effect such changes without cost to the OWNER. This shall include the cost for redesign and claims of other contractor affected by the resulting change.
- B. The procedure for review by the ENGINEER will include the following:
1. If the CONTRACTOR wishes to furnish or use a substitute item of material or equipment, the CONTRACTOR shall make written application to the ENGINEER on the "Substitution Request Form" for acceptance thereof.
  2. Unless otherwise provided by law or authorized in writing by the ENGINEER, the "Substitution Request Form(s)" shall be submitted within the 21-day period after Notice of Award.
  3. Wherever a proposed substitute material or equipment has not been submitted within said 21-day period, or wherever the submission of a proposed substitute material or equipment has been judged to be unacceptable by the ENGINEER, the CONTRACTOR shall provide material or equipment named in the Contract Documents.
  4. The CONTRACTOR shall certify that the proposed substitute will perform adequately the functions and achieve the results called for by the general design, be similar and of equal substance to that specified, and be suited to the same use as that specified.
  5. The ENGINEER will be allowed a reasonable time within which to evaluate each proposed substitute. In no case will this reasonable time period be less than 14 days.
  6. As applicable, no shop drawing submittals will be made for a substitute item nor will any substitute item be ordered, installed, or utilized without the ENGINEER's prior written acceptance of the CONTRACTOR's "Substitution Request Form" which will be evidenced by a Change Order.
  7. The ENGINEER will record the time required by the ENGINEER in evaluating substitutions proposed by the CONTRACTOR and in making changes in the Contract Documents occasioned thereby. Whether or not the ENGINEER accepts a proposed substitute, the CONTRACTOR shall reimburse the OWNER for the charges of the ENGINEER for evaluating each proposed substitute.

## SECTION 01300 - CONTRACTOR SUBMITTALS

- C. The CONTRACTOR's application using the "Substitution Request Forms" shall contain the following statements and/or information which shall be considered by the ENGINEER in evaluating the proposed substitution:
1. The evaluation and acceptance of the proposed substitute will not prejudice the CONTRACTOR's achievement of substantial completion on time.
  2. Whether or not acceptance of the substitute for use in the WORK will require a change in any of the Contract Documents to adopt the design to the proposed substitute.
  3. Whether or not incorporation or use of the substitute in connection with the WORK is subject to payment of any license fee or royalty.
  4. All variations of the proposed substitute for that specified will be identified.
  5. Available maintenance, repair, and replacement service and its estimated cost will be indicated.
  6. Itemized estimate of all costs that will result directly or indirectly from acceptance of such substitute, including cost of redesign and claims of other contractors affected by the resulting change.

### 1.9 MATERIAL CERTIFICATON SUBMITTAL

- A. The ENGINEER may permit the use, prior to sampling, inspection and testing, of certain materials or assemblies when accompanied by manufacturer's material certifications stating that such materials or assemblies fully comply with the requirements of the Contract. The certification shall be signed by the manufacturer, and will specifically reference the material's compliance with the AASHTO, ASTM and/or CBW Standards specified in the applicable Contract Documents.
- B. Material Certifications shall be submitted to the engineer prior to incorporating the item into the WORK.
- C. Materials or assemblies used on the basis of material certifications may be sampled, inspected and/or tested at any time, and if found not in conformity with these Specifications, will be subject to rejection whether in place or not.

**PART 2 - PRODUCTS (not used)**

**PART 3 - EXECUTION (not used)**

**(SUBSTITUTION REQUEST FORM – next page)**

**SECTION 01300 - CONTRACTOR SUBMITTALS**

**City & Borough of Wrangell  
SUBSTITUTION REQUEST FORM**

TO: \_\_\_\_\_ Project: \_\_\_\_\_  
Contract No. \_\_\_\_\_  
OWNER: \_\_\_\_\_

SPECIFIED ITEM:

Section	Page	Paragraph	Description
---------	------	-----------	-------------

The undersigned requests consideration of the following:

PROPOSED SUBSTITUTION: \_\_\_\_\_

Attached data includes product description, specifications, drawings, photographs, performance and test data adequate for evaluation of the request. Applicable portions of the data are clearly identified.

The undersigned states that the following paragraphs, unless modified on attachments are correct:

1. The proposed substitution does not affect dimensions shown on Drawings and will not require a change in any of the Contract Documents.
2. The undersigned will pay for changes to the design, including engineering design, detailing, and construction costs caused by the requested substitution which is estimated to be \$\_\_\_\_\_.
3. The proposed substitution will have no adverse affect on other contractors, the construction schedule (specifically the date of substantial completion), or specified warranty requirements.
4. Maintenance and service parts will be locally available for the proposed substitution.
5. The incorporation or use of the substitute in connection with the WORK is not subject to payment of any license fee or royalty.

The undersigned further states that the function, appearance, and quality of the Proposed Substitution are equivalent or superior to the Specified item.

Submitted by CONTRACTOR: _____	Reviewed by ARCHITECT/ENGINEER _____
Signature _____	<input type="checkbox"/> Accepted <input type="checkbox"/> Accepted as Noted
Firm: _____	<input type="checkbox"/> Not Accepted <input type="checkbox"/> Received Too Late
By: _____	Date: _____
Title: _____	Telephone: _____
Date: _____	
Attachments: _____	

**END OF SECTION**

## SECTION 01505 - MOBILIZATION

### PART 1 - GENERAL

#### 1.1 GENERAL

- A. Mobilization shall include the obtaining of all permits; moving onto the site of all plant and equipment; furnishing and erecting plants, temporary buildings, and other construction facilities; and implementing security requirements; all as required for the proper performance and completion of the WORK. Mobilization shall include the following principal items:
1. Moving on to the site of all CONTRACTOR's plant and equipment required for operations.
  2. Providing all on-site communication facilities, including radios and cellular phones.
  3. Obtaining all required permits.
  4. Having all OSHA required notices and establishment of safety programs.
  5. Having the CONTRACTOR's superintendent at the job site full time.
  6. Submitting initial submittals.

#### 1.2 PAYMENT FOR MOBILIZATION

- A. As soon as practicable after receipt of the Notice to Proceed, the CONTRACTOR shall submit a breakdown to the ENGINEER for approval, which shall show the estimated value of each major component of Mobilization. When approved by the ENGINEER, the breakdown will be the basis for initial progress payments in which Mobilization is included.

### PART 2 – PRODUCTS (Not Used)

### PART 3 – EXECUTION (Not Used)

**END OF SECTION**

## SECTION 01520 - SECURITY

### PART 1 - GENERAL

#### 1.1 SECURITY PROGRAM

A. The CONTRACTOR shall:

1. Protect WORK, existing premises and OWNER's operations from theft, vandalism, and unauthorized entry.
2. Coordinate security with OWNER's operations at job mobilization.
3. Maintain program throughout construction period until OWNER's occupancy.

#### 1.2 ENTRY CONTROL

A. The CONTRACTOR shall:

1. Control entry of persons and vehicles onto Project construction site and existing facilities.
2. Allow entry on the construction site only to authorized persons with proper identification.
3. Coordinate access of OWNER's personnel to site in coordination with CONTRACTOR's security forces.

B. OWNER will control entrance of persons and vehicles related to OWNER's operations.

### PART 2 - PRODUCTS (Not Used)

### PART 3 - EXECUTION (Not Used)

**END OF SECTION**

## SECTION 01530 - PROTECTION AND RESTORATION OF EXISTING FACILITIES

### PART 1 - GENERAL

#### 1.1 GENERAL

- A. The CONTRACTOR shall protect all existing utilities and improvements not designated for removal and shall restore damaged or temporarily relocated utilities and improvements to a condition equal to or better than they were prior to such damage or temporary relocation, all in accordance with requirements of the Contract Documents.
- B. All utility locates shall be the responsibility of the CONTRACTOR. For aid in utility location call, Public Works for water and sewer and Municipal Light & Power for electrical, at least two working days prior to beginning construction.
- C. The CONTRACTOR shall verify the exact locations and depths of all utilities and the CONTRACTOR shall make exploratory excavations of all utilities that may interfere with the WORK. All such exploratory excavations shall be performed as soon as practicable after award of the contract and, in any event, a sufficient time in advance of construction to avoid possible delays to the CONTRACTOR's work. Any utility or service in conflict with the WORK will be reburied by the CONTRACTOR prior beginning the WORK to avoid damage.
- D. The number of exploratory excavations required shall be that number which is sufficient to determine the alignment and grade of the utility.

#### 1.2 RIGHTS-OF-WAY

- A. The CONTRACTOR shall not do any work that would affect any sewer or water pipeline; any telephone, cable television, or electric transmission line; any fence; or any other structure, nor shall the CONTRACTOR enter upon the rights-of-way involved until notified by the ENGINEER that the OWNER has secured authority therefore from the proper party. After authority has been obtained, the CONTRACTOR shall give said party due notice of its intention to begin work, if required by said party, and shall remove, shore, support or otherwise protect such pipeline, transmission line, ditch, fence, or structure or replace the same. When two or more contracts are being executed at one time on the same or adjacent land in such manner that work on one contract may interfere with that on another, the OWNER shall determine the sequence and order of the WORK. When the territory of one contract is the necessary or convenient means of access for the execution of another contract, such privilege of access or any other reasonable privilege may be granted by the OWNER to the CONTRACTOR so desiring, to the extent, amount, in the manner, and at the times permitted.
- B. No such decision as to the method or time of conducting the WORK or the use of territory shall be made the basis of any claim for delay or damage, except as provided for temporary suspension of the WORK in Article 15 of the General Conditions of the contract.

#### 1.3 PROTECTION OF SURVEY MONUMENTS, STREET AND/OR ROADWAY MARKERS

- A. The CONTRACTOR shall not destroy, remove, or otherwise disturb any existing survey markers or other existing street or roadway markers without proper authorization. No



## SECTION 01530 - PROTECTION AND RESTORATION OF EXISTING FACILITIES

pavement breaking or excavation shall be started until all survey or other permanent marker points that will be disturbed by the construction operations have been properly referenced. All survey monuments, markers or points disturbed by the CONTRACTOR shall be accurately re-established, at the CONTRACTOR's expense unless provided for elsewhere in the contract, after all street or roadway resurfacing has been completed. Re-establishment of all survey monuments shall be by a Registered Alaskan Land Surveyor.

### 1.4 RESTORATION OF PAVEMENT

- A. General: All paved areas, including asphalt concrete berms, cut or damaged during construction shall be replaced with similar materials and of equal thickness to match the existing adjacent undisturbed areas, except where specific resurfacing requirements have been called for in the Contract Documents or in the requirements of the agency issuing the permit. All temporary and permanent pavement shall conform to the requirements of the affected pavement owner. All pavements which are subject to partial removal shall be neatly saw cut in straight lines.
- B. Temporary Resurfacing: Wherever required by the public authorities having jurisdiction, the CONTRACTOR shall place temporary surfacing promptly after backfilling and shall maintain such surfacing for the period of time fixed by said authorities before proceeding with the final restoration of improvements.
- C. Permanent Resurfacing: In order to obtain a satisfactory junction with adjacent surfaces, the CONTRACTOR shall saw cut back and trim the edge so as to provide a clean, sound, vertical joint before permanent replacement of an excavated or damaged portion of pavement. Damaged edges of pavement along excavations and elsewhere shall be trimmed back by saw cutting in straight lines. All pavement restoration and other facilities restoration shall be constructed to finish grades compatible with adjacent undisturbed pavement.
- D. Restoration of Sidewalks or Private Driveways: Wherever sidewalks or private roads have been removed for purposes of construction, the CONTRACTOR shall place suitable temporary sidewalks or roadways promptly after backfilling and shall maintain them in satisfactory condition for the period of time fixed by the authorities having jurisdiction over the affected portions before proceeding with the final restoration or, if no such period of times is so fixed, the CONTRACTOR shall maintain said temporary sidewalks or roadways until the final restoration thereof has been made.

### 1.5 EXISTING UTILITIES AND IMPROVEMENTS

- A. General: The CONTRACTOR shall protect all Underground Utilities and other improvements which may be impaired during construction operations. It shall be the CONTRACTOR's responsibility to ascertain the actual location of all existing utilities and other improvements that will be encountered in its construction operations, and to see that such utilities or other improvements are adequately protected from damage due to such operations. The CONTRACTOR shall take all possible precautions for the protection of unforeseen utility lines to provide for uninterrupted service and to provide such special protection as may be necessary.
- B. Utilities to be Moved: In case it shall be necessary to move the property of any public

## SECTION 01530 - PROTECTION AND RESTORATION OF EXISTING FACILITIES

utility or franchise holder, such utility company or franchise holder will, upon request of the CONTRACTOR, be notified by the OWNER to move such property within a specified reasonable time. When utility lines that are to be removed are encountered within the area of operations, the CONTRACTOR shall notify the ENGINEER a sufficient time in advance for the necessary measures to be taken to prevent interruption of service.

- C. Where the proper completion of the WORK requires the temporary or permanent removal and/or relocation of an existing utility or other improvement which is indicated, the CONTRACTOR shall remove and, without unnecessary delay, temporarily replace or relocate such utility or improvement in a manner satisfactory to the ENGINEER and the owner of the facility. In all cases of such temporary removal or relocation, restoration to former location shall be accomplished by the CONTRACTOR in a manner that will restore or replace the utility or improvement as nearly as possible to its former locations and to as good or better condition than found prior to removal.
- D. OWNER's Right of Access: The right is reserved to the OWNER and to the owners of public utilities and franchises to enter at any time upon any public street, alley, right-of-way, or easement for the purpose of making changes in their property made necessary by the WORK of this contract.
- E. Underground Utilities Indicated: Existing utility lines that are indicated or the locations of which are made known to the CONTRACTOR prior to excavation and that are to be retained, and all utility lines that are constructed during excavation operations shall be protected from damage during excavation and backfilling and, if damaged, shall be immediately repaired or replaced by the CONTRACTOR.
- F. Underground Utilities Not Indicated: In the event that the CONTRACTOR damages any existing utility lines that are not indicated or the locations of which are not made known to the CONTRACTOR prior to excavation, a written report thereof shall be made immediately to the ENGINEER. If directed by the ENGINEER, repairs shall be made by the CONTRACTOR under the provisions for changes and extra work contained in Articles 10, 11, and 12 of the General Conditions.
- G. All costs of locating, repairing damage not due to failure of the CONTRACTOR to exercise reasonable care, and removing or relocating such utility facilities not shown in the Contract Documents with reasonable accuracy, and for equipment on the project which was actually working on that portion of the WORK which was interrupted or idled by removal or relocation of such utility facilities, and which was necessarily idled during such work will be paid for as extra work in accordance with the provisions of Articles 10, 11, and 12 of the General Conditions.
- H. Approval of Repairs: All repairs to a damaged utility or improvement are subject to inspection and approval by an authorized representative of the utility or improvement owner before being concealed by backfill or other work.
- I. Maintaining in Service: All oil and gasoline pipelines, power, and telephone, cable television or the communication cable ducts, gas and water mains, irrigation lines, sewer lines, storm drain lines, poles, and overhead power and communication wires and cables encountered along the line of the WORK shall remain continuously in service during all

## SECTION 01530 - PROTECTION AND RESTORATION OF EXISTING FACILITIES

the operations under the Contract, unless other arrangements satisfactory to the ENGINEER are made with the owner of said pipelines, duct, main, irrigation line, sewer, storm drain, pole, or wire or cable. The CONTRACTOR shall be responsible for and shall repair all damage due to its operations, and the provisions of this Section shall not be abated even in the event such damage occurs after backfilling or is not discovered until after completion of the backfilling.

### 1.6 TREES WITHIN STREET RIGHTS-OF-WAY AND PROJECT LIMITS

- A. General: The CONTRACTOR shall exercise all necessary precautions so as not to damage or destroy any trees or shrubs outside the limits of clearing and grubbing and shall not trim or remove any trees unless such trees have been approved for trimming or removal by the jurisdictional agency or OWNER. All existing trees and shrubs which are damaged during construction shall be trimmed or replaced by the CONTRACTOR or a certified tree company under permit from the jurisdictional agency and/or the OWNER. Tree trimming and replacement shall be accomplished in accordance with the following paragraphs.
- B. Trimming: Symmetry of the tree shall be preserved; no stubs or splits or torn branches left; clean cuts shall be made close to the trunk or large branch. Spikes shall not be used for climbing live trees. All cuts over 1-1/2 inches in diameter shall be coated with an asphaltic emulsion material.
- C. Replacement: The CONTRACTOR shall immediately notify the jurisdictional agency and/or the OWNER if any tree is damaged by the CONTRACTOR's operations. If, in the opinion of said agency or the OWNER, the damage is such that replacement is necessary, the CONTRACTOR shall replace the tree at its own expense. The tree shall be of a like size and variety as the tree damaged, or, the CONTRACTOR shall pay to the owner of said tree a compensatory payment acceptable to the tree owner, subject to the approval of the jurisdictional agency or OWNER.

### 1.7 PROTECTION OF EXISTING STRUCTURES

- A. Compaction Equipment and Operations: The CONTRACTOR shall restrict its compaction operations as necessary to assure no damage occurs to adjacent buildings. This may require the use of smaller compaction equipment than is usually employed for trench backfill and roadway embankment compaction operations when in the vicinity of buildings sensitive to vibrating or other impact-type activities. It shall be the CONTRACTOR's responsibility to determine in which areas of the project the compaction operations must be restricted, to avoid damage to existing buildings. The CONTRACTOR is advised that some structures on the project, especially those founded on steep or unstable ground, and are especially sensitive to vibrations caused by heavy construction equipment. The foregoing restrictions on the size of, and magnitude of impact energy exerted by, compaction equipment will in no way relieve the CONTRACTOR from the compaction requirements as specified in other Sections of the contract.
- B. The CONTRACTOR shall notify all affected businesses and other residents in advance of any operations that will cause vibrations that may damage belongings within the buildings. All property damage caused by the CONTRACTOR's operations shall be

**SECTION 01530 - PROTECTION AND RESTORATION OF EXISTING FACILITIES**

repaired or replaced at CONTRACTOR's expense.

**PART 2 PRODUCTS – (Not Used)**

**PART 3 EXECUTION - (Not used)**

**END OF SECTION**

## SECTION 01550 - SITE ACCESS AND STORAGE

### PART 1 - GENERAL

#### 1.1 HIGHWAY LIMITATIONS

The CONTRACTOR shall make its own investigation of the condition of available public and private roads and of clearances, restrictions, bridge load limits, and other limitations affecting transportation and ingress and egress to the site of the WORK. It shall be the CONTRACTOR's responsibility to construct and maintain any haul roads required for its construction operations.

#### 1.2 MAINTENANCE OF TRAFFIC

- A. General: Unless otherwise provided, existing roadways shall be kept open to all traffic by the CONTRACTOR. Nothing herein shall be construed to entitle the CONTRACTOR to the exclusive use of any public street, alleyway, or parking area during the performance of the WORK hereunder, and it shall so conduct its operations as not to interfere unnecessarily with the authorized work of utility companies or other agencies in such streets, alleyways, or parking areas. The CONTRACTOR shall provide unimpeded access through the Project limits for emergency vehicles and make every effort to provide minimum delay to emergency service vehicles and garbage collection vehicles.
- B. The CONTRACTOR shall submit three (3) copies of a traffic control plan to the ENGINEER for approval a minimum of two (2) weeks prior to construction. The ENGINEER reserves the right to observe these traffic control plans in use and to make any changes as field conditions warrant. Any changes shall supersede these plans and be done solely at the CONTRACTOR's expense.
- C. No street shall be closed to the public without first obtaining permission of the ENGINEER and proper governmental authority. Where so provided on the plans or otherwise approved by the ENGINEER, the CONTRACTOR may by-pass traffic over a detour route. When no longer required, the detour shall be removed and the approached obliterated.
- D. Where excavation is being performed in primary streets or highways, one lane in each direction shall be kept open to traffic at all times unless otherwise indicated. Toe boards shall be provided to retain excavated material if required by the ENGINEER or the agency having jurisdiction over the street or highway. Fire hydrants on or adjacent to the WORK shall be kept accessible to fire-fighting equipment at all times. Temporary provisions shall be made by the CONTRACTOR to assure the use of sidewalks and the proper functioning of all gutters, storm drain inlets, and other drainage facilities.
- E. The CONTRACTOR's equipment shall stop at all points of intersection with the traveling public unless satisfactory traffic control measures, approved in writing by the ENGINEER, are installed and maintained at CONTRACTOR's expense.
- F. When the CONTRACTOR is required to maintain traffic through grading, roadway excavation and embankment areas, the construction shall be conducted in such a manner as to provide a reasonably smooth and even surface satisfactory for use by public traffic at all times. The surface of the roadbed shall be properly crowned for drainage. In advance of other grading operations, sufficient fill shall be placed at culverts and bridges to permit traffic to cross unimpeded. Part width construction techniques shall be employed when the traffic is routed through roadway cuts or over embankments under construction. The material shall be excavated or placed in layers and the construction activities shall be alternated from one side to the other, with traffic routed over the side opposite the one under construction.

## SECTION 01550 - SITE ACCESS AND STORAGE

- G. During the removal and laying of culvert pipe, a maximum time of one hour of road closure may be permitted, providing the removal and laying of the culvert pipe cannot be completed for one-half width of the roadway and provided that a detour cannot be constructed around the culvert being laid. Closure shall be scheduled so as not to delay buses and peak hour traffic. The CONTRACTOR shall post, at the site of the closure within view of the waiting public traffic, the time the closure started and the time the road will again be open to traffic. The CONTRACTOR shall notify the Fire and Police Departments of such closures prior to commencement of work.
- H. At intervals of 48 hours and 24 hours prior to start up of construction operations, and at weekly intervals during the construction period, the CONTRACTOR shall advertise at Borough Assembly the precise location, time of commencement, and proposed completion date of the WORK scheduled for the following week which will require detouring or otherwise effect public traffic. Detours shall be described in sufficient detail to efficiently inform the traveling public of the modified traffic pattern. The cost of these advertisements shall be considered incidental to other contract bid items. The CONTRACTOR will notify the property owners 24 hours prior to commencement of WORK.
- I. When, in the opinion of the ENGINEER, conditions are such that the safety and/or convenience of the traveling public are adversely affected, the CONTRACTOR will be immediately notified in writing. The notice will state the defect(s) and the corrective action(s) required. In the event that the CONTRACTOR neglects to take immediate corrective action, the ENGINEER may suspend all work on the project until satisfactory corrective action is performed. In the event the CONTRACTOR does not take corrective action within 24 hours, the ENGINEER may order such work as deemed necessary for public convince and safety accomplished by outside forces. The cost of this work shall be deducted from any monies due or that may become due under the terms or the contract.
- J. The CONTRACTOR shall bear all expense of maintaining the traffic over adjacent existing roads, including dust control and snow plowing, and of constructing and maintaining such approaches, crossings, intersections, and other features as may be necessary, without direct compensation, except as provided below:
1. Special Detours. Contractor may detour traffic to the AISC clinic via Etolin Street to bypass majority of construction activities. All signage and maintenance of the detour route shall be provided by the contractor. Coordinate with water department personnel to provide continuous access to the water treatment plant.
  2. Maintenance of Traffic during Suspension of WORK. The CONTRACTOR shall make passable and shall open to traffic such portions of the Project and temporary roadways as may be agreed upon between the CONTRACTOR and the ENGINEER for the temporary accommodation of necessary traffic during the anticipated period of suspension. If the suspension is seasonal (winter shutdown), thereafter, and until an issuance of an order for the resumption of construction operations, the maintenance of the temporary route of line of travel agreed upon will be the responsibility of the OWNER. Prior to the OWNER accepting the Project for winter shutdown, the CONTRACTOR shall do all work necessary to provide a roadway surface and subgrade that will not require the OWNER to perform additional maintenance work during the shutdown period, except for purpose of snow removal. If the WORK is suspended due to unfavorable weather, failure of the CONTRACTOR to correct conditions unsafe for the workers or the general public, failure to carry out provisions of the contract, or for failure to carry out orders of the ENGINEER, all costs for maintenance of traffic during the suspended period shall be borne by the CONTRACTOR. When WORK is resumed, the CONTRACTOR shall replace

## SECTION 01550 - SITE ACCESS AND STORAGE

or renew any WORK or materials lost or damaged because of temporary use of the project; shall remove, to the extent directed by the ENGINEER, any WORK or materials used in the temporary maintenance; and shall complete the Project as though its prosecution had been continuous and without interference.

- K. Traffic Control: All locations requiring redirection or stopping of the traveling public shall be properly signed and/or flagged by the CONTRACTOR. For the protection of traffic in public or private streets and ways, the CONTRACTOR shall provide, flaggers and provide, place, and maintain all necessary barricades, traffic cones, warning signs, lights, and other safety devices in accordance with the requirements of the "Manual of Uniform Traffic Control Devices, Part VI - Traffic Controls for Street and Highway Construction and Maintenance Operations," (MUTCD) published by U.S. Department of Transportation, Federal Highway Administration (ANSI D6.1) with the current State of Alaska supplements.
- L. The CONTRACTOR shall take all necessary precautions for the protection of the WORK and the safety of the public. All barricades and obstructions shall be illuminated at night, and all lights shall be kept burning from sunset until sunrise. The CONTRACTOR shall station such guards or flaggers and shall conform to such special safety regulations relating to traffic control as may be required by the public authorities within their respective jurisdictions. All signs, signals, and barricades shall conform to the requirements of Subpart G, Part 1926, of the OSHA Safety and Health Standards for Construction.
- M. Special pedestrian detours are often necessary in areas adjacent to new construction or demolition of existing structures. The ENGINEER shall determine when walkways are required. Plans for walkways must be approved by the ENGINEER.
- N. The CONTRACTOR shall remove traffic control devices when no longer needed, repair all damage caused by installation of the devices, and shall remove post settings and backfill the resulting holes to match grade.
- O. Temporary Street Closure: If closure of any street is required during construction, the CONTRACTOR shall apply in writing to the City & Borough of Wrangell Public Works Department and Alaska Department of Transportation and Public Facilities and any other jurisdictional agency at least 30 days in advance of the required closure and again at 48 hours. A Detour and Traffic Control Plan shall accompany the application.
- P. The CONTRACTOR shall notify the Police and Fire Departments and any other affected agency of all planned street closures. Notification shall consist of giving the time of commencement and proposed date of completion of work and names of street, schedule of operations, and routes of detours. Such notification shall be given at least 48 hours before such closure is to take effect.
- Q. Temporary Driveway Closure: The CONTRACTOR shall maintain access to all residential, commercial and street approaches. Any temporary closures shall require prior approval by the ENGINEER. The CONTRACTOR shall notify the owner or occupant (if not owner-occupied) of the closure of the driveways to be closed more than one (1) eight-hour work day at least three (3) working days prior to the closure. The CONTRACTOR shall minimize the inconvenience and minimize the time period that the driveways will be closed. The CONTRACTOR shall fully explain to the owner/occupant how long the work will take and when closure is to start.
- R. On-Site Cellular Phones: The CONTRACTOR shall maintain one active cellular phone at the project site at all times with the phone number provided to the City of Wrangell Fire, Police and Public Works Departments. The cellular phone shall be carried by the person in charge of the field operations. The CONTRACTOR shall provide and allow

## SECTION 01550 - SITE ACCESS AND STORAGE

the use of the CONTRACTOR's radio frequency to facilitate communication between the CONTRACTOR and the ENGINEER.

### 1.3 CONTRACTOR'S WORK AND STORAGE AREA

- A. The CONTRACTOR shall make its own arrangements for any necessary off-site storage or shop areas necessary for the proper execution of the WORK.
- B. Should the CONTRACTOR find it necessary to use any additional land for its camp or for other purposes during the construction of the WORK, it shall provide for the use of such lands at its own expense.
- C. The CONTRACTOR shall construct and use a separate storage area for hazardous materials used in constructing the WORK.
  - 1. For the purpose of this paragraph, hazardous materials to be stored in the separate area are all products labeled with any of the following terms: **Warning, Caution, Poisonous, Toxic, Flammable, Corrosive, Reactive, or Explosive**. In addition, whether or not so labeled, the following materials shall be stored in the separate area: diesel fuel, gasoline, new and used motor oil, hydraulic fluid, cement, paints and paint thinners, two-part epoxy coatings, sealants, asphaltic products, glues, solvents, wood preservatives, sand blast materials, and spill absorbent.
  - 2. The CONTRACTOR shall develop and submit to the ENGINEER a plan for storing and disposing of the materials above.
  - 3. The CONTRACTOR shall obtain and submit to the ENGINEER a single EPA number for wastes generated at the site.
  - 4. The separate storage area shall meet all the requirements of all authorities having jurisdiction over the storage of hazardous materials.
  - 5. The separate storage area shall be inspected by the ENGINEER prior to construction of the area, upon completion of construction of the area, and upon cleanup and removal of the area.
  - 6. All hazardous materials which are delivered in containers shall be stored in the original containers until use. Hazardous materials which are delivered in bulk shall be stored in containers which meet the requirements of authorities having jurisdiction.

### 1.4 PARKING

- A. The CONTRACTOR shall direct its employees to park in areas as directed by the ENGINEER.
- B. Traffic and parking areas shall be maintained in a sound condition, free of excavated material, construction equipment, mud, and construction materials. The CONTRACTOR shall repair breaks, potholes, low areas which collect standing water, and other deficiencies.

**PART 2 - PRODUCTS (Not Used)**

**PART 3 - EXECUTION (Not Used)**

**END OF SECTION**



## SECTION 01600 - MATERIALS AND EQUIPMENT

### PART 1 - GENERAL

#### 1.1 GENERAL

- A. The word "Products," as used herein, is defined to include purchased items for incorporation into the WORK, regardless of whether specifically purchased for project or taken from CONTRACTOR's stock of previously purchased products. The word "Materials," is defined as products which must be substantially cut, shaped, worked, mixed, finished, refined, or otherwise fabricated, processed, installed, or applied to form units of work. The word "Equipment" is defined as products with operational parts, regardless of whether motorized or manually operated, and particularly including products with service connections (wiring, piping, and other like items). Definitions in this paragraph are not intended to negate the meaning of other terms used in Contract Documents, including "specialties," "systems," "structure," "finishes," "accessories," "furnishings," special construction," and similar terms, which are self-explanatory and have recognized meanings in the construction industry.
- B. Neither "Products" nor "Materials" nor "Equipment" includes machinery and equipment used for preparation, fabrication, conveying and erection of the WORK.

#### 1.2 QUALITY ASSURANCE

- A. Source Limitations: To the greatest extent possible for each unit of WORK, the CONTRACTOR shall provide products, materials, or equipment of a singular generic kind from a single source.
- B. Compatibility of Options: Where more than one choice is available as options for CONTRACTOR's selection of a product, material, or equipment, the CONTRACTOR shall select an option which is compatible with other products, materials, or equipment already selected. Compatibility is a basic general requirement of product/material selections.

- 1.3 PRODUCT DELIVERY/STORAGE/HANDLING. The CONTRACTOR shall deliver, handle, and store products in accordance with manufacturer's written recommendations and by methods and means which will prevent damage, deterioration, and loss including theft. Delivery schedules shall be controlled to minimize long-term storage of products at site and overcrowding of construction spaces. In particular, the CONTRACTOR shall ensure minimum holding or storage times for products recognized to be flammable, hazardous, easily damaged, or sensitive to deterioration, theft, and other sources of loss.

#### 1.4 TRANSPORTATION AND HANDLING

- A. Products shall be transported by methods to avoid product damage and shall be delivered in undamaged condition in manufacturer's unopened containers or packaging.
- B. The CONTRACTOR shall provide equipment and personnel to handle products, materials, and equipment by methods to prevent soiling and damage.
- C. The CONTRACTOR shall provide additional protection during handling to prevent marring and otherwise damaging products, packaging, and surrounding surfaces.

## SECTION 01600 - MATERIALS AND EQUIPMENT

### 1.5 STORAGE AND PROTECTION

- A. Products shall be stored in accordance with manufacturer's written instructions, with seals and labels intact and legible. Sensitive products shall be stored in weather-tight climate controlled enclosures and temperature and humidity ranges shall be maintained within tolerances required by manufacturer's written instructions.
- B. For exterior storage of fabricated products, they shall be placed on sloped supports above ground. Products subject to deterioration shall be covered with impervious sheet covering; ventilation shall be provided to avoid condensation.
- C. Loose granular materials shall be stored on solid surfaces in a well-drained area and shall be prevented from mixing with foreign matter.
- D. Storage shall be arranged in a manner to provide access for maintenance and inspection. The CONTRACTOR shall periodically inspect to assure products are undamaged and are maintained under required conditions.

### 1.6 MAINTENANCE OF STORAGE

- A. Stored products shall be periodically inspected on a scheduled basis. The CONTRACTOR shall maintain a log of inspections and shall make said log available to the ENGINEER on request.
- B. The CONTRACTOR shall verify that storage facilities comply with manufacturer's product storage requirements.
- C. The CONTRACTOR shall verify that manufacturer-required environmental conditions are maintained continually.
- D. The CONTRACTOR shall verify that surfaces of products exposed to the elements are not adversely affected and that any weathering of finishes does not occur.
- E. For mechanical and electrical equipment, the CONTRACTOR shall provide a copy of the manufacturer's service instructions with each item and the exterior of the package shall contain notice that instructions are included.
- F. Products shall be serviced on a regularly scheduled basis, and a log of services shall be maintained and submitted as a record document prior to acceptance by the OWNER in accordance with the Contract Documents.

**PART 2 - PRODUCTS (Not Used)**

**PART 3 - EXECUTION (Not Used)**

**END OF SECTION**

## SECTION 01700 - PROJECT CLOSE-OUT

### PART 1 – GENERAL

- 1.1 FINAL CLEAN-UP. The CONTRACTOR shall promptly remove from the vicinity of the completed work, all rubbish, unused materials, concrete forms, construction equipment, and temporary structures and facilities used during construction. Final acceptance of the WORK by the OWNER will be withheld until the CONTRACTOR has satisfactorily complied with the foregoing requirements for final clean-up of the project site.
- 1.2 FINAL SUBMITTALS. The CONTRACTOR, prior to requesting final payment, shall obtain and submit the following items to the ENGINEER for transmittal to the OWNER:
- A. Written guarantees, where required.
  - B. Maintenance stock items; spare parts, special tools, where required.
  - C. Completed record drawings.
  - D. Certificates of inspection and acceptance by governing agencies having jurisdiction.
  - E. Releases from all parties who are entitled to claims against the subject Project, property, or improvement pursuant to the provisions of law.
  - F. Certificate of Compliance and Release form from all contractors involved in the WORK. Submit the original signed document to the OWNER's Project Manager.
- 1.3 MAINTENANCE AND GUARANTEE
- A. The CONTRACTOR shall comply with the maintenance and guarantee requirements contained in Article 13 of the General Conditions.
  - B. Replacement of earth fill or backfill, where it has settled below the required finish elevations, shall be considered as a part of such required repair work, and any repair or resurfacing constructed by the CONTRACTOR which becomes necessary by reason of such settlement shall likewise be considered as a part of such required repair work unless the CONTRACTOR shall have obtained a statement in writing from the affected private owner or public agency releasing the OWNER from further responsibility in connection with such repair or resurfacing.
  - C. The CONTRACTOR shall make all repairs and replacements promptly upon receipt of written order from the OWNER. If the CONTRACTOR fails to make such repairs or replacements promptly, the OWNER reserves the right to do the WORK and the CONTRACTOR and his surety shall be liable to the OWNER for the cost thereof.
- 1.4 BOND. The CONTRACTOR shall provide a bond to guarantee performance of the provisions contained in Paragraph "Maintenance and Guarantee" above, and Article 13 of the General Conditions.

### PART 2 - PRODUCTS (Not Used)

### PART 3 - EXECUTION (Not Used)

**END OF SECTION**

## **SECTION 01704 - FINAL CLEAN-UP AND SITE RESTORATION**

### **PART 1 - GENERAL**

- 1.1 DESCRIPTION. The WORK under this Section includes providing all supervision, labor, materials, tools and equipment necessary for final clean-up and restoration of all areas disturbed by construction activities, to a condition equal to, or better than, before construction started. This does not include clean-up or restoration incidental to, or directly provided for by, other construction items.

### **PART 2 - PRODUCTS**

- 2.1 MATERIALS. Any materials required shall conform to the appropriate Section of these Specifications.

### **PART 3 - EXECUTION**

#### **3.1 CONSTRUCTION**

- A. The CONTRACTOR shall clean up all sites disturbed during construction of the project. This includes removal of all construction equipment, disposal of all excess materials, disposal of all rubbish and debris, removal of all temporary structures, and grading of the sites so that no standing water is evident.

**END OF SECTION**

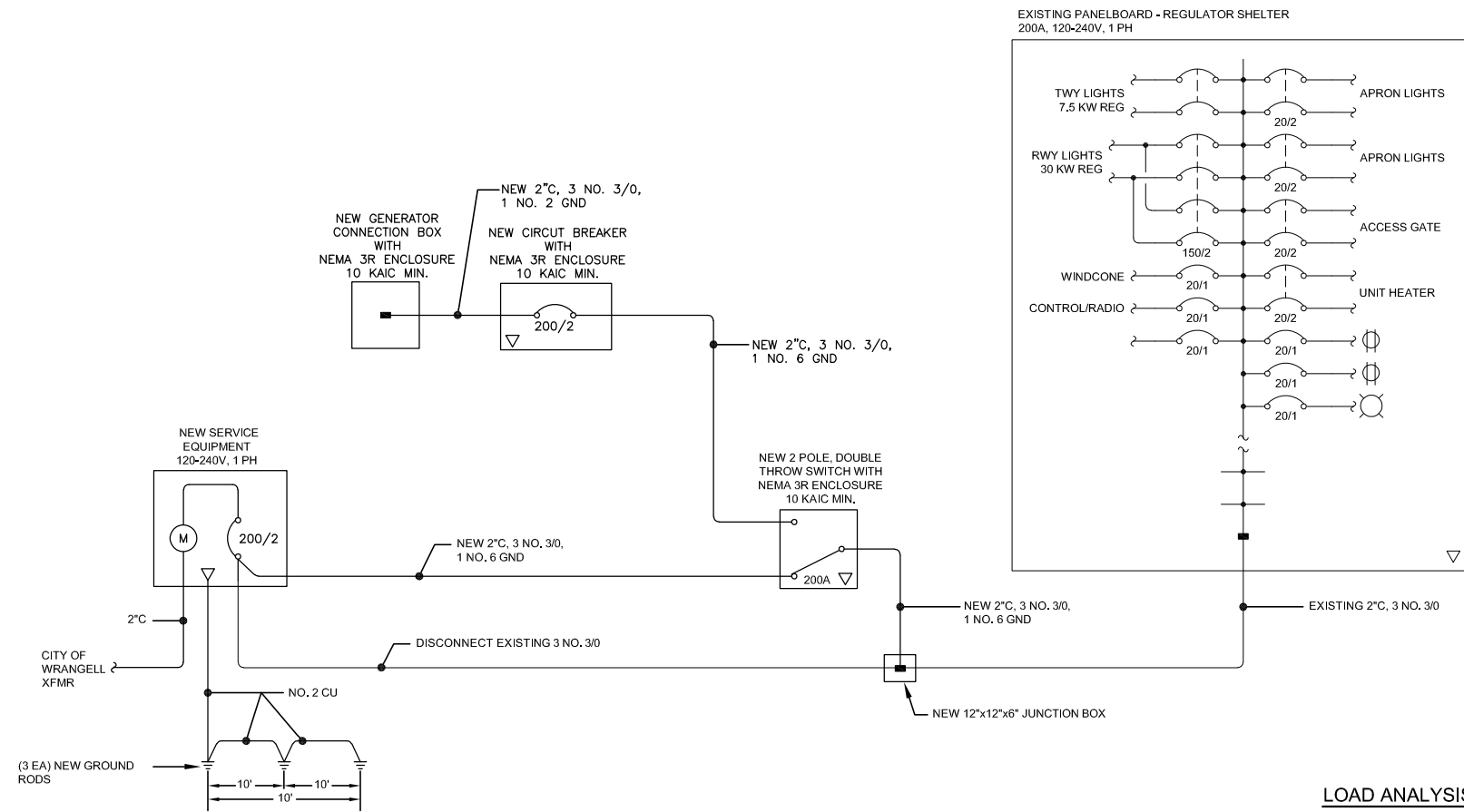

1 SINGLE LINE DIAGRAM - POWER DISTRIBUTION

LOAD ANALYSIS	KVA
TWY/RWY REGULATORS	22.6
APRON LIGHTS	6.6
HEATER	5.0
ACCESS GATE/CONTROLS	1.5
WINDCONE/RECEPTACLES/LIGHTS	35.7 (149A)

THE CALCULATED MAXIMUM FAULT CURRENT AT THE METER IS 7,975 AMPERES. ALL OF THE EXISTING EQUIPMENT APPEARS TO BE RATED AT 10,000 OR MORE.

LEGEND

ABBREVIATIONS:

AFG	ABOVE FINISHED GRADE
C	CONDUIT
GND	GROUND
HDG	HOT-DIPPED GALVANIZED
TS	TRANSFER SWITCH

SHEET NOTE SYMBOLS:

(N)	NEW
X	SECTION/SHEET CALLOUT

POWER:

⊕	DUPLEX RECEPTACLE
---	-------------------

LIGHTING:

⊙	LUMINAIRE
---	-----------

SERVICE EQUIPMENT:

▭	PANELBOARD
⊞	UTILITY METER

DIAGRAM SYMBOLS:

⊞	AUTOMATIC TRANSFER SWITCH
⊞	CIRCUIT BREAKER
⊞	GROUND BUS
⊞	GROUND ROD
⊞	METER
⊞	TERMINAL BLOCK

CONSULTANT:

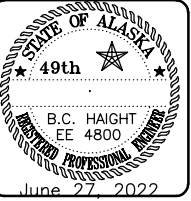

Juneau, AK  
526 Main St  
Juneau, AK 99801  
Phone: 907.586.5788  
Fax: 907.586.5774  
AECOC 65270



PROJECT:

City of Wrangell  
WRANGELL AIRPORT AIRFIELD  
LIGHTING  
WRANGELL, ALASKA

SHEET TITLE:

LEGEND  
SINGLE LINE DIAGRAM

DESIGN	BCH	
DRAWN	PEL	
CHECKED	BCH	
DATE	6/27/2022	
PROJECT No.	201-03	
SHEET NUMBER	E1.0	
No.	Date	Item
REVISIONS		

IF THIS BAR DOES NOT MEASURE EXACTLY ONE INCH, THE SCALE OF THIS DRAWING HAS BEEN ALTERED DURING ITS PRODUCTION, AFFECTING ALL LABELED SCALES

N:\Projects\201 - City of Wrangell\03 Wrangell Airport Airfield Generator Drawings\Working\EL1\_Layout1 Jan 18, 2023 4:08 PM

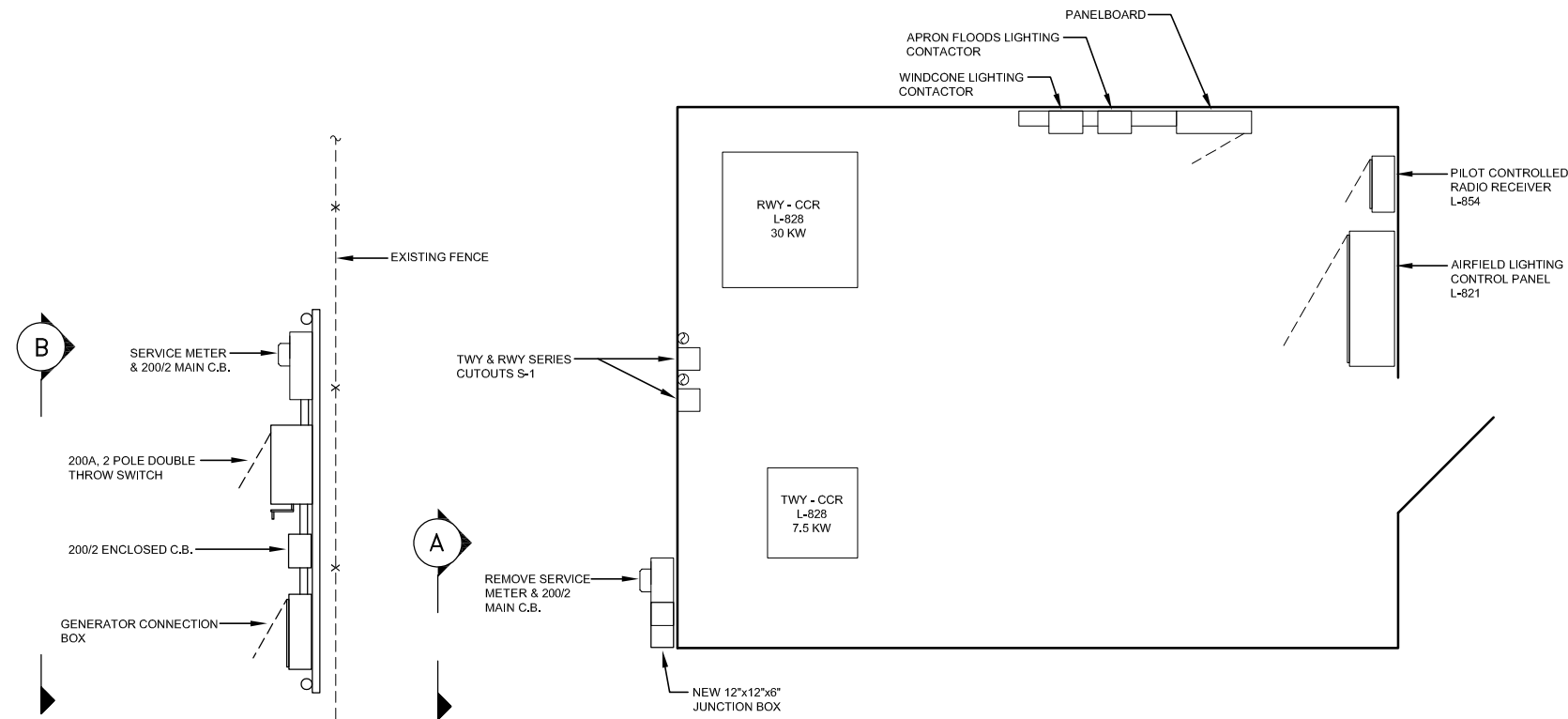

**1 PLAN VIEW - AIRFIELD LIGHTING SHELTER**  
SCALE: 0 1' 2' 4'

- NOTES:
- EXISTING BUILDING AND ELECTRICAL COMPONENTS ARE ILLUSTRATED WITH NEW ITEMS IDENTIFIED.
  - COORDINATE STAND LOCATION WITH OWNER.

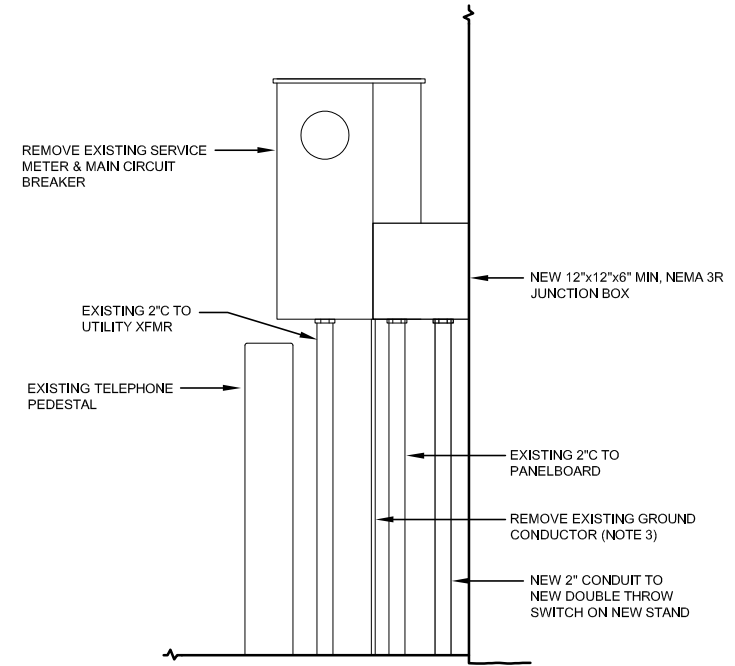

**A ELEVATION - SERVICE METER & MAIN CIRCUIT BREAKER**  
SCALE: 0 6" 1' 2'

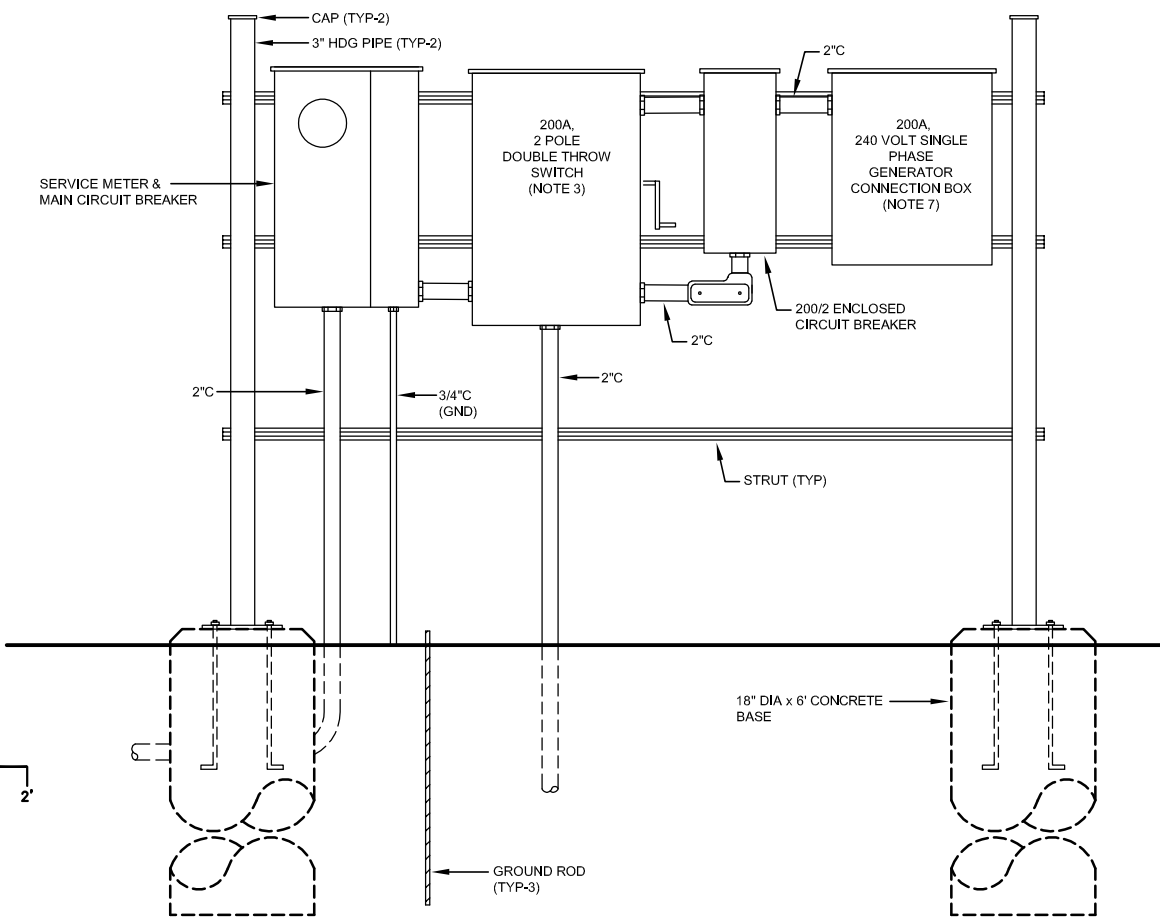

**B ELEVATION - ELECTRICAL EQUIPMENT STAND**  
SCALE: 0 6" 1' 2'

- NOTES:
- REMOVE THE EXISTING SERVICE METER AND 200A MAIN CIRCUIT BREAKER.
  - REROUTE THE SERVICE FEEDER TO THE NEW METER AND 200A MAIN CIRCUIT BREAKER ON THE STAND.
  - ROUTE A FEEDER FROM THE DOUBLE THROW SWITCH ON THE STAND TO A NEW JUNCTION BOX ON THE BUILDING AND SPLICE TO THE EXISTING FEEDER TO THE PANELBOARD INSIDE THE BUILDING.
  - ALL CONDUIT SHALL BE HOT-DIPPED GALVANIZED STEEL AND ALL ENCLOSURES SHALL BE NEMA 3R. PROVIDE AN ADDITIONAL COAT OF PAINT ON ENCLOSURES BEFORE INSTALLATION.
  - ALL CONDUCTORS SHALL BE STRANDED COPPER WITH XHHW-2 INSULATION. GROUND CONDUCTORS SHALL BE BARE COPPER.
  - GROUND ELECTRODES SHALL BE COPPER CLAD 5/8" DIA x 8' LONG STEEL RODS.
  - GENERATOR CONNECTION BOX: NON SWITCHING, 120-240V, SINGLE PHASE, 200A, SINGLE NEUTRAL, WITH NEMA 3R ENCLOSURE AND CAM CONNECTION. UNION CONNECTOR GCP-N-O-2-200-1-1-1-0-0.
  - PROVIDE (5 EA) SINGLE CONDUCTOR, 2/0 AWG, 50 FT LONG TYPE W CABLES WITH CAM FITTINGS ON ONE END AND LUGS ON THE OTHER. COORDINATE CAM FITTINGS WITH GENERATOR CONNECTION BOX.
  - PROVIDE THE DOUBLE THROW SWITCH WITH PADLOCK HASPS ALLOWING IT TO BE LOCKED IN EITHER POSITION.

DESIGN	BCH	
DRAWN	PEL	
CHECKED	BCH	
DATE	6/27/2022	
PROJECT No. 201-03		
SHEET NUMBER		
<b>E1.1</b>		
No.	Date	Item
REVISIONS		

CONSULTANT:



**Juneau, AK**  
526 Main St.  
Juneau, AK 99801  
Phone: 907.586.3788  
Fax: 907.586.5774  
AECC 65270

PROJECT:  
**City of Wrangell  
WRANGELL AIRPORT AIRFIELD  
LIGHTING**  
WRANGELL, ALASKA

SHEET TITLE:  
**PLAN VIEW - AIRFIELD LIGHTING  
SHELTER**