

WRANGELL MARINE SERVICE CENTER

BOAT HAULOUT PIER STRUCTURAL UPGRADES

PROJECT MANUAL



Prepared by:



9360 Glacier Highway, Suite 100
Juneau, Alaska 99801

MARCH 2013

SECTION 00005 - TABLE OF CONTENTS

DIVISION 0 - BIDDING AND CONTRACT REQUIREMENTS, CONTRACT FORMS, AND CONDITIONS OF THE CONTRACT

BIDDING and CONTRACT REQUIREMENTS No. of Pages

00005	Table of Contents	2
00030	Notice Inviting Bids	2
00100	Instructions to Bidders	7
00300	Bid	2
00310	Bid Schedule	1
00320	Bid Bond	1
00360	Subcontractor Report	2

CONTRACT FORMS

00500	Agreement	6
00610	Performance Bond	2
00620	Payment Bond	2

CONDITIONS OF THE CONTRACT

00700	General Conditions	46
00800	Supplementary General Conditions	3
00830	Alaska Labor Standards, Reporting & Prevailing Wage Rate Determination	1
00852	Permits.....	1

TECHNICAL SPECIFICATIONS

DIVISION 1 - GENERAL REQUIREMENTS

01010	Summary of Work	4
01025	Measurement and Payment	3
01045	Cutting and Patching	3
01070	Acronyms of Institutions	3
01090	Reference Standards	2
01300	Contractor Submittals	8
01400	Quality Control	2
01500	Field Office.....	1
01505	Mobilization.....	1
01520	Security.....	1
01530	Protection and Restoration of Existing Facilities	4
01550	Site Access and Storage	5
01560	Temporary Environmental Controls	2
01570	Erosion Control	1
01600	Materials and Equipment	2
01700	Project Close-out	2
01704	Final Clean-up and Site Restoration	1

SECTION 00005 - TABLE OF CONTENTS

DIVISION 2 - SITEWORK

02060	Demolition, Salvage and Disposal	1
02896	Steel Pipe Piles	4

DIVISION 3 GROUTING

03303	Grouting.....	3
-------	---------------	---

DIVISION 5 METALS

05120	Structural Steel	6
-------	------------------------	---

SUBMITTAL REGISTER	6
---------------------------------	---

DRAWING INDEX

SHEET NO.	DRAWING NO.	TITLE
1 of 9	1.01	Cover Sheet, Vicinity Map, & Drawing Index
2 of 9	1.02	Site Construction, Staging Plan
3 of 9	1.03	Overall Dock Plan
4 of 9	2.01	Dock Plan
5 of 9	2.02	Typical Sections
6 of 9	2.03	Typical Sections and Details
7 of 9	2.04	Backwall Abutment
8 of 9	2.05	Pile Caps and Sub Pile Caps (For Reference Only)
9 of 9	2.06	Deck Details

END OF SECTION

SECTION 00030 - NOTICE INVITING BIDS

OBTAINING CONTRACT DOCUMENTS. The Contract Documents are entitled:

WRANGELL MARINE SERVICE CENTER – BOAT HAULOUT PIER STRUCTURAL UPGRADES

Notice is hereby given that the City and Borough of Wrangell, Alaska will receive sealed bids for the construction of Wrangell Marine Service Center – Boat Haulout Pier Structural Upgrades.

The Contract Documents, including one set of reduced scale drawings, may be obtained at the Borough Clerk's Office, 205 Brueger Street, Wrangell, Alaska 99929 (Ph. 907-874-2381). A non-refundable fee of \$50.00 made payable to the City and Borough of Wrangell is required for each set of contract documents. Additional charges will be required for special handling or delivery of the documents by means other than first class mail. The Contract Documents may also be downloaded free of charge on the City and Borough of Wrangell website (www.wrangell.com) under the Bids and RFP's section. Downloading Contract Documents from the City and Borough of Wrangell's website requires registration with the Borough Clerk in order to be placed on the Plan holders List and to ensure receipt of subsequent Addenda. Failure to register may adversely affect your proposal. It is the Offeror's responsibility to insure that they have received all Addenda affecting this Solicitation. To be registered, contact the Borough Clerk at 907-874-2381 or at clerk@wrangell.com

DESCRIPTION OF WORK. WORK consists of all activities necessary to construct the Wrangell Marine Service Center Boat Haulout Pier Structural Upgrades as shown in the contract documents. Work includes strengthening the concrete deck from below by installing steel beams and grouting between the beams and the concrete deck. The Engineer's Estimate for the Base Bid is between \$800,000 and \$950,000..

SITE OF WORK. The WORK is located in downtown Wrangell, Alaska adjacent to the Nolan Center and Wrangell Seafoods.

COMPLETION OF WORK. The OWNER will open the work site to the CONTRACTOR immediately following the Notice to Proceed. Substantial completion shall be **October 1, 2013**. All WORK under the contract documents shall be completed by **November 1, 2014**.

BIDDING, CONTRACT, or TECHNICAL QUESTIONS. All communications relative to this WORK, prior to opening Bids, shall be directed to the following:

Amber Al-Haddad
Project Manager
Telephone: (907) 874-3494

PRE-BID CONFERENCE. Prospective bidders are encouraged to attend a Pre-Bid Conference that will be held in Wrangell on **April 9, 2013** beginning at 11:00 AM at the City and Borough Council Chambers at City Hall. The purpose of the conference is to acquaint Bidders with site conditions, construction phasing and answer questions on bid documents. Attendance by teleconference will be available by calling **Dial-in number: 1 (888) 550-5602 and entering the access code: 7214 8291**.

BID SECURITY. Each bid shall be accompanied by a bid bond, cashier's check or certified check made payable to the City and Borough of Wrangell in the amount of five percent of the total bid price. This serves as a guarantee that the Bidder, if its Bid is accepted, will promptly execute the Agreement. A Bid shall not be considered unless one of the forms of Bidder's security is enclosed with it.

RECEIPT OF BIDS. Sealed bids will be received by the City and Borough of Wrangell, Post Office Box 531, Wrangell, Alaska 99929, located at the Borough Clerk's Office, 205 Brueger Street, Wrangell, Alaska

SECTION 00030 - NOTICE INVITING BIDS

99929 until 2:00 PM prevailing time on **April 18, 2013** Opening date and time may be changed to a later date or time via Addendum. Clearly mark on the outside of the envelope **“Request for bids, Marine Service Center Boat Haulout Pier Structural Upgrades, Opening Date April 18, 2013”**. Proposals may not be withdrawn for ninety days following date of opening.

OPENING OF BIDS. The Bids will be publicly opened and read at 2:00 PM on **April 18, 2013** in the City Council Chambers of the City and Borough of Wrangell, Alaska.

SUBCONTRACTORS. The apparent low Bidder is required to complete and submit the following documentation within five calendar days following the posting of bids by the City and Borough of Wrangell:

- City & Borough of Wrangell Finance Department Verification, Section 00300.
- Subcontractor Report, Section 00360.

CONTRACTOR'S LICENSE. All contractors are required to submit a copy of their current Alaska Contractor's License and a current Alaska Business License with the bid.

BID TO REMAIN OPEN. The Bidder shall guarantee the Bid for a period of 90 Days from the date of Bid opening. Any component of the Bid including additive alternates may be awarded anytime during the 90 Days.

OWNER'S RIGHTS RESERVED. The OWNER reserves the right to reject any or all Bids, to waive any informality in a Bid, and to make award to the lowest responsive, responsible Bidder as it may best serve the interests of the OWNER.

OWNER: the City and Borough of Wrangell

By: _____
Timothy Rooney, City and Borough Manager

Date

END OF SECTION

SECTION 00100 - INSTRUCTIONS TO BIDDERS

1.0 DEFINED TERMS. Terms used in these “Instructions to Bidders” and the “Notice Inviting Bids” which are defined in the General Conditions have the meanings assigned to them in the General Conditions. The term "Bidder" means one who submits a Bid directly to the OWNER, as distinct from a sub-bidder, who submits a Bid to a Bidder.

2.0 INTERPRETATIONS AND ADDENDA.

A. **INTERPRETATIONS.** All questions about the meaning or intent of the Contract Documents are to be directed to the Project Manager. Interpretations or clarifications considered necessary by the Project Manager in response to such questions will be issued by Addendum, mailed, faxed, emailed, or delivered to all parties recorded by the Project Manager, or OWNER, as having received the Contract Documents. Questions received less than (7) seven days prior to the date for opening of Bids may not be answered. Only questions answered by formal written Addendum will be binding. Oral and other interpretations or clarifications will be without legal effect.

B. **ADDENDA.** Addenda may be issued to modify the Contract Documents as deemed advisable by the OWNER. The OWNER may issue addenda by fax or email. Addenda may be faxed or emailed less than seven Days prior to the anticipated Bid opening. The OWNER will make all reasonable attempts to ensure that all plan holders receive faxed addenda, however, it is strongly recommended by the OWNER that Bidders independently confirm the contents, number, and dates of each Addenda prior to submitting a Bid.

3.0 FAIR COMPETITION. More than one Bid from an individual, firm, partnership, corporation, or association under the same or different names will not be considered. If the OWNER believes that any Bidder is interested in more than one Bid for the WORK contemplated, all Bids in which such Bidder is interested will be rejected. If the OWNER believes that collusion exists among the Bidders, all Bids will be rejected.

4.0 RESPONSIBLE BIDDER. Only responsive Bids from responsible Bidders will be considered. A Bid submitted by a Bidder determined to be not responsible may be rejected. A responsible Bidder is one who is considered to be capable of performing the WORK.

A. The general standards for responsibility are to determine the CONTRACTOR’s ability to perform WORK adequately, considering the CONTRACTOR’s

1. Financial Resources
2. Ability to Meet Delivery Standards
3. Past Performance Record
 - a. References from others on CONTRACTOR’s performance
 - b. Record of performance on prior OWNER contracts
4. Record of Integrity
5. Obligations to OWNER
 - a. Bidders must be registered as required by law and in good standing for all amounts owed to the OWNER within five Days of OWNER’s Notice of Intent to Award.

SECTION 00100 - INSTRUCTIONS TO BIDDERS

- b. The City and Borough of Wrangell administers the registration and assessment of sales, business personal property and business real property taxes.
- B. Special standards for responsibility, if applicable, will be specified. These special standards establish minimum standards or experience required for a responsible Bidder on a specific contract.
- C. Before a Bid is considered for award, a Bidder may be requested to submit information documenting its ability and competency to perform the WORK, according to general standards of responsibility and any special standards which may apply. It is Bidder's responsibility to submit sufficient, relevant, and adequate information. OWNER will make its determination of responsibility and has no obligation to request clarification or supplementary information.

5.0 RESPONSIVE BIDS. Only responsive Bids will be considered. Bids may be considered non-responsive and may be rejected. Some of the reasons a Bid may be rejected for being non-responsive are:

- A. If the Bid is on a form other than that furnished by the OWNER, or legible copies thereof; or if the form is altered or any part thereof is detached; or if the Bid is improperly signed.
- B. If there are unauthorized additions, conditional or alternate bids, or irregularities of any kind which may tend to make the proposal incomplete, indefinite, or ambiguous as to its meaning.
- C. If the Bidder adds any unauthorized conditions, limitations, or provisions reserving the right to accept or reject any award, or to enter into a contract pursuant to an award. This does not exclude a Bid limiting the maximum gross amount of awards acceptable to any one Bidder at any one bid opening, provided that any selection of awards will be made by the OWNER.
- D. If the Bid does not contain a unit price for each pay item listed, except in the case of authorized alternate pay items.
- E. If the Bidder has not acknowledged receipt of each Addendum.
- F. If the Bidder fails to furnish an acceptable Bid guaranty with the Bid.
- G. If any of the unit prices Bid are excessively unbalanced (either above or below the amount of a reasonable Bid) to the potential detriment of the OWNER.
- H. If a bid modification does not conform to Article 15.0 of this Section.

6.0 BIDDER'S EXAMINATION OF CONTRACT DOCUMENTS AND SITE. It is the responsibility of each Bidder before submitting a Bid:

- A. To examine thoroughly the Contract Documents, and other related data identified in the bidding documents (including "technical data" referred to below):
 - 1. To visit the site to become familiar with and to satisfy the Bidder as to the general and local conditions that may affect cost, progress, or performance, of the WORK,

SECTION 00100 - INSTRUCTIONS TO BIDDERS

2. To consider federal, state and local laws and regulations that may affect cost, progress, or performance of the WORK,
3. To study and carefully correlate the Bidder's observations with the Contract Documents, and other related data; and
4. To notify the ENGINEER of all conflicts, errors, or discrepancies in or between the Contract Documents and such other related data.

7.0 REFERENCE IS MADE TO THE SUPPLEMENTARY GENERAL CONDITIONS FOR IDENTIFICATION OF:

- A. Those reports of explorations and tests of subsurface conditions at the site which have been utilized by the Engineer of Record in the preparation of the Contract Documents. The Bidder may rely upon the accuracy of the technical data contained in such reports, however, the interpretation of such technical data, including any interpolation or extrapolation thereof, together with non-technical data, interpretations, and opinions contained therein or the completeness thereof is the responsibility of the Bidder.
- B. Those drawings of physical conditions in or relating to existing surface and subsurface conditions (except underground utilities) which are at or contiguous to the site have been utilized by the Engineer of Record in the preparation of the Contract Documents. The Bidder may rely upon the accuracy of the technical data contained in such drawings, however, the interpretation of such technical data, including any interpolation or extrapolation thereof, together with non-technical data, interpretations, and opinions contained in such drawings or the completeness thereof is the responsibility of the Bidder.
- C. Copies of such reports and drawings will be made available by the OWNER to any Bidder on request if said reports and drawings are not bound herein. Those reports and drawings are not part of the Contract Documents, but the technical data contained therein upon which the Bidder is entitled to rely, as provided in Paragraph SGC-4.2 of the Supplementary General Conditions, are incorporated herein by reference.
- D. Information and data reflected in the Contract Documents with respect to underground utilities at or contiguous to the site is based upon information and data furnished to the OWNER and the Engineer of Record by the owners of such underground utilities or others, and the OWNER does not assume responsibility for the accuracy or completeness thereof unless it is expressly provided otherwise in the Supplementary General Conditions, or in Section 01530 - Protection and Restoration of Existing Facilities.
- E. Provisions concerning responsibilities for the adequacy of data furnished to prospective Bidders on subsurface conditions, underground utilities and other physical conditions, and possible changes in the Contract Documents due to differing conditions appear in Paragraphs 4.2, 4.3, and 4.4 of the General Conditions.
- F. Before submitting a Bid, each Bidder will, at its own expense, make or obtain any additional examinations, investigations, explorations, tests, and studies and obtain any additional information and data which pertain to the physical conditions (surface, subsurface, and underground utilities) at or contiguous to the site or otherwise which may affect cost, progress, or performance of the WORK and which the Bidder deems necessary to determine its Bid for performing the WORK in accordance with the time, price, and other terms and conditions of the Contract Documents.

SECTION 00100 - INSTRUCTIONS TO BIDDERS

- G. On request in advance, the OWNER will provide each Bidder access to the site to conduct such explorations and tests as each Bidder deems necessary for submission of a Bid. Bidder shall fill all holes and shall clean up and restore the site to its former condition upon completion of such explorations.
- H. The lands upon which the WORK is to be performed, rights-of-way and easements for access thereto and the lands designated for use by the CONTRACTOR in performing the WORK are identified in the Contract Documents. All additional lands and access thereto required for temporary construction facilities or storage of materials and equipment are to be provided by the CONTRACTOR. Easements for permanent structures or permanent changes in existing structures are to be obtained and paid for by the OWNER unless otherwise provided in the Contract Documents.
- I. The submission of a Bid will constitute an incontrovertible representation by the Bidder that the Bidder has complied with every requirement of Article 6, "Bidder's Examination of Contract Documents and Site" herein, that without exception the Bid is premised upon performing the WORK required by the Contract Documents and such means, methods, techniques, sequences, or procedures of construction as may be indicated in or required by the Contract Documents, and that the Contract Documents are sufficient in scope and detail to indicate and convey understanding of all terms and conditions for performance of the WORK.

8.0 BID FORM.

- A. The Bid shall be made on the Bid Schedule(s) bound herein, or on the yellow bid packet provided, or on legible and complete copies thereof, and shall contain the following: Sections 00300, 00310, and the required Bid Security. In the event there is more than one Bid Schedule, the Bidder may bid on any individual schedule or on any combination of schedules. The envelope enclosing the sealed Bids shall be plainly marked in the upper left-hand corner with the name and address of the Bidder and shall bear the words "BID FOR," followed by the title of the Contract Documents for the WORK, the name of the OWNER, the address where Bids are to be delivered or mailed to, and the date and hour of opening of Bids. The Bid Security shall be enclosed in the same envelope with the Bid.
- B. All blanks on the Bid Form and Bid Schedule must be completed in ink or typed.
- C. Bids by corporations must be executed in the corporate name by the president, a vice-president (or other corporate officer). The corporate address and state of incorporation must appear below the signature.
- D. Bids by partnerships must be executed in the partnership name and be signed by a managing partner, and the official address of the partnership must appear below the signature.
- E. The Bidder's Bid must be signed with ink. All names must be printed or typed below the signature.
- F. The Bid shall contain an acknowledgment of receipt of all Addenda, the numbers of which shall be filled in on the Bid Form. Failure to acknowledge Addenda shall render Bid non-responsive and shall cause its rejection.

SECTION 00100 - INSTRUCTIONS TO BIDDERS

- G. The address to which communications regarding the Bid are to be directed must be shown.
- H. All Bidders must provide evidence of authority to conduct business in Alaska to the extent required by law. A Bid for the WORK will not be accepted from a contractor who does not hold a valid Alaska Business License and a valid Contractor's License in Alaska (applicable to the type of work bid upon) at the time of opening Bids.
- 9.0 QUANTITIES OF WORK.** The quantities of WORK, or material, stated in unit price items of the Bid are supplied only to give an indication of the general scope of the WORK; the OWNER does not expressly or by implication agree that the actual amount of WORK, or material, will correspond therewith, and reserves the right after award to increase or decrease the amount of any unit price item of the WORK by an amount up to and including 25 percent of any Bid item, without a change in the unit price, and shall include the right to delete any Bid item in its entirety, or to add additional Bid items up to and including an aggregate total amount not to exceed 25 percent of the Contract Price (see General Conditions, Article 10 Changes In the Work).
- 10.0 SUBSTITUTE OR "OR-EQUAL" ITEMS.** The procedure for the submittal of substitute or "or-equal" products is specified in Section 01300 - CONTRACTOR SUBMITTALS.
- 11.0 SUBMISSION OF BIDS.** The Bid shall be delivered by the time and to the place stipulated in the Notice Inviting Bids. It is the Bidder's sole responsibility to see that its Bid is received in proper time. Oral, email, telephonic or faxed Bids will not be considered.
- 12.0 BID SECURITY, BONDS, AND INSURANCE.** Each Bid shall be accompanied by a certified, or cashier's check, or approved Bid Bond in an amount of at least 5 percent of the total Bid price. The "total Bid price" is the amount of the base bid, plus the amount of alternate bids, if any, which total to the maximum amount for which the contract could be awarded. Said check or Bond shall be made payable to the OWNER and shall be given as a guarantee that the Bidder, if offered the WORK, will enter into an Agreement with the OWNER, and will furnish the necessary insurance certificates, Payment Bond, and Performance Bond; each of said Bonds, if required, and insurance amounts shall be as stated in the Supplementary General Conditions. In case of refusal or failure to enter into said Agreement, the check or Bid Bond, as the case may be, shall be forfeited to the OWNER. If the Bidder elects to furnish a Bid Bond as its Bid security, the Bidder shall use the Bid Bond form bound herein, or one conforming substantially to it in form. Bid Bonds must be accompanied by a legible power of attorney.
- 13.0 RETURN OF BID SECURITY.** Within 14 Days after award of the contract, the OWNER will return the Bid securities accompanying such of the Bids as are not considered in making the award. All other Bid securities will be held until the Agreement has been executed. They will then be returned to the respective Bidders whose Bids they accompanied.
- 14.0 DISCREPANCIES IN BIDS.** In the event there is more than one pay item in a Bid Schedule, the Bidder shall furnish a price for all pay items in the schedule, and failure to do so may render the Bid non-responsive and cause its rejection. In the event there are unit price pay items in a Bid Schedule, and the "amount" indicated for a unit price pay item does not equal the product of the unit price and quantity, the unit price shall govern and the amount will be corrected accordingly, and the Bidder shall be bound by said correction. In the event there is more than one pay item in the Bid Schedule and the total indicated for the schedule does not agree with the sum of the prices bid on the individual items, the prices bid on the individual items shall govern and the total for the schedule will be corrected accordingly, and the Bidder shall be bound by said correction.

SECTION 00100 - INSTRUCTIONS TO BIDDERS

15.0 BID MODIFICATIONS AND UNAUTHORIZED ALTERNATIVE BIDS.

- A. Any Bidder may modify a Bid by mail, email (clerk@wrangell.com), or fax (**Fax: 907-874-3952**) at any time prior to the scheduled closing time for receipt of Bids, provided that such modification is received by the City and Borough of Wrangell prior to the time set for opening of Bids. Bidders are strongly advised to telephone the City and Borough of Wrangell (**Telephone: 907-874-2381**), prior to the time set for opening Bids, to confirm the successful and timely transmission of their electronic Bid modification.

A mail, email or fax modification should not reveal the Bid price but should provide the addition or subtraction or other modification so that the final prices will not be known by the City and Borough of Wrangell until the sealed Bid is opened. Modifications shall include both the modification of the unit bid price and the total modification of each item modified. The City and Borough of Wrangell shall not be responsible for its failure to receive email or fax modifications whether such failure is caused by transmission line problems, electronically delivered device problems, operator error or otherwise.

- B. Unauthorized conditions, limitations, or provisos attached to the Bid will render it informal and cause its rejection as being non-responsive. The completed bid forms shall be without interlineation, alterations, or erasures in the printed text. All changes shall be initialed by the person signing the Bid. Alternative bids will not be considered unless called for.

16.0 WITHDRAWAL OF BID. The Bid may be withdrawn by the Bidder by means of a written request, signed by the Bidder or its properly authorized representative. Such written request must be delivered to the place stipulated in the Notice Inviting Bids for receipt of Bids prior to the scheduled closing time for receipt of Bids.

17.0 AWARD OF CONTRACT.

- A. Award of a contract, if it is awarded, will be on the basis of materials and equipment described in the Drawings or specified in the Technical Specifications and will be made to the lowest responsive, responsible Bidder whose Bid complies with all the requirements prescribed. Unless otherwise specified, any such award will be made within the period stated in the Notice Inviting Bids that the Bids are to remain open. Unless otherwise indicated, a single award will be made for all the bid items in an individual Bid Schedule.
- B. In the event the WORK is contained in more than one Bid Schedule, the OWNER may award schedules individually or in combination. In the case of two Bid Schedules which are alternative to each other, only one of such alternative schedules will be awarded.
- C. If the OWNER has elected to advertise this Project with a base bid and additive or deductive alternates, the OWNER may elect to award the contract for the base bid, or the base bid plus any alternates, in any combination of alternates as selected by the OWNER. In either case, award shall be made to the responsive, responsible Bidder offering the lowest total bid for the WORK to be awarded.

18.0 EXECUTION OF AGREEMENT.

SECTION 00100 - INSTRUCTIONS TO BIDDERS

- A. All Bids less than or equal to \$25,000 do not require Wrangell Borough Assembly approval. The Bidder to whom award is made for a Bid that is more than \$25,000 shall execute a written agreement with the OWNER on the Agreement form, Section 00500, and shall secure all insurance and any other documents required by the contract within 10 calendar Days from the date stated in the Notice of Intent to Award letter.
- B. All Bids greater than \$25,000 must be approved by the Wrangell Borough Assembly. After the Wrangell Borough Assembly has approved the award, the OWNER will issue of Notice of Intent to Award to the approved Bidder. The Bidder to whom award is made shall execute a written Agreement with the OWNER on the Agreement form, Section 00500, and shall secure all insurance and furnish all certificates and bonds required by the Contract Documents within 10 calendar Days from the date stated in the Notice of Intent to Award letter.
- C. Failure or refusal to enter into the Agreement as herein provided or to conform to any of the stipulated requirements in connection therewith shall be just cause for annulment of the award and forfeiture of the Bid security. If the lowest responsive, responsible Bidder refuses or fails to execute the Agreement, the OWNER may award the contract to the second lowest responsive, responsible Bidder. If the second lowest responsive, responsible Bidder refuses or fails to execute the Agreement, the OWNER may award the contract to the third lowest responsive, responsible Bidder. On the failure or refusal of such second or third lowest Bidder to execute the Agreement, each such Bidder's Bid securities shall be likewise forfeited to the OWNER.

19.0 LIQUIDATED DAMAGES. Provisions for liquidated damages if any are set forth in Section 00500 - Agreement.

20.0 PERMITS. The CONTRACTOR is responsible for all WORK associated with meeting any local, state, and/or federal permit requirements.

END OF SECTION

SECTION 00300 - BID

BID TO: THE CITY AND BOROUGH OF WRANGELL

1. The undersigned Bidder proposes and agrees, if this Bid is accepted, to enter into an Agreement with the OWNER on the form included in the Contract Documents (as defined in Article 7 of Section 00500 - AGREEMENT) to perform the WORK as specified or indicated in said Contract Documents entitled

WRANGELL MARINE SERVICE CENTER – BOAT HAULOUT STRUCTURAL PIER UPGRADES

2. Bidder accepts all of the terms and conditions of the Contract Documents, including without limitation those in the “Notice Inviting Bids” and “Instructions to Bidders,” dealing with the disposition of the Bid Security.
3. This Bid will remain open for the period stated in the “Notice Inviting Bids” unless otherwise required by law. Bidder will enter into an Agreement within the time and in the manner required in the “Notice Inviting Bids” and the “Instructions to Bidders,” and will furnish insurance certificates, Payment Bond, Performance Bond, and any other documents as may be required by the Contract Documents.
4. Bidder has familiarized itself with the nature and extent of the Contract Documents, WORK, site, locality where the WORK is to be performed, the legal requirements (federal, state and local laws, ordinances, rules, and regulations), and the conditions affecting cost, progress or performance of the WORK and has made such independent investigations as Bidder deems necessary.
5. This Bid is genuine and not made in the interest of or on behalf of any undisclosed person, firm or corporation and is not submitted in conformity with any agreement or rules of any group, association, organization or corporation; Bidder has not directly or indirectly induced or solicited any other Bidder to submit a false or sham Bid; Bidder has not solicited or induced any person, firm or corporation to refrain from bidding; and Bidder has not sought by collusion to obtain for itself any advantage over any other Bidder or over OWNER.
6. To all the foregoing, and including all Bid Schedule and information required of Bidder contained in this Bid Form, said Bidder further agrees to complete the WORK required under the Contract Documents within the Contract Time stipulated in said Contract Documents, and to accept in full payment therefor the Contract Price based on the total bid price(s) named in the aforementioned Bid Schedule.
7. Bidder has examined copies of all the Contract Documents including the following Addenda (receipt of all of which is hereby acknowledged by the Undersigned):

Addenda No.	Date Issued	Addenda No.	Date Issued

Give number and date of each Addenda above. Failure to acknowledge receipt of all Addenda will cause the Bid to be non-responsive and shall cause its rejection.

SECTION 00300 - BID

8. The Bidder has read this Bid and agrees to the conditions as stated herein by signing in the space provided below.

Dated: _____	Bidder: _____ (Company Name)
	By: _____ (Signature in Ink)
Alaska Business License No.: _____	Printed Name: _____
Contractor's License No.: _____	Title: _____
Telephone No.: _____	Address: _____ (Street or P.O. Box)
Fax No.: _____	_____ (City, State, Zip)

9. TO BE CONSIDERED, ALL BIDDERS MUST COMPLETE AND INCLUDE THE FOLLOWING AT THE TIME OF THE BID OPENING:

- Signed Bid, Section 00300 (includes Addenda receipt statement)
- Completed Bid Schedule, Section 00310
- Bid Security (Bid Bond, Section 00320, or by a certified or cashier's check as stipulated in the Notice Inviting Bids, Section 00030)
- Contractor's License and Alaska Business License

10. Unless otherwise notified by the Borough Manager within (5) calendar days of posting the apparent low bidder, the apparent low Bidder is required to complete and submit the following documents:

- Subcontractor Report, Section 00360
- Verification from Wrangell Finance Department that Subcontractors are current with City and Borough of Wrangell Sales and Property Taxes, Section 00360

The apparent low Bidder who fails to submit a completed Subcontractor Report within the time specified in Section 00360 – Subcontractor Report will be found to be not a responsible Bidder and may be required to forfeit the Bid security. The OWNER will then consider the next lowest Bidder for award of the contract.

11. The successful Bidder will be required to submit, within ten calendar Days after the date stated in the "Notice of Intent to Award" letter, the following executed documents:

- Agreement Forms, Section 00500
- Performance Bond, Section 00610
- Payment Bond, Section 00620
- Certificates of Insurance, (CONTRACTOR and Subcontractors) Section 00700 and Section 00800
- Alaska Department of Labor/Borough Clerk, Subcontractor List, Section 00830.
- One executed copy of each subcontract for WORK that exceeds one half of one percent of the intended contract award amount.

END OF SECTION

SECTION 00310 - BID SCHEDULE

BASE BID

Pay Item No.	Pay Item Description	Pay Unit	Approximate Quantity	Unit Price		Amount	
				Dollars	Cents	Dollars	Cents
1505.1	Mobilization	LS	All Req'd				
2060.1	Demolition, Salvage and Disposal	LS	All Req'd				
2896.1	Batter Piles and Connections	EA					
3303.1	Grouting	LS	All Req'd				
5120.1	Structural Steel: Beams	LF					
5120.2	Structural Steel Connections	EA					

TOTAL BASE BID AMOUNT IN FIGURES: \$ _____

TOTAL BASE BID AMOUNT

IN WORDS: _____

COMPANY NAME: _____

SECTION 00320 - BID BOND

KNOW ALL PERSONS BY THESE PRESENTS, that _____

_____ as Principal, and _____

as Surety, are held and firmly bound unto **THE CITY AND BOROUGH OF WRANGELL** hereinafter called

"OWNER," in the sum of _____

_____ dollars, (not less than five percent of the total amount of the Bid) for the payment of which sum, well and truly to be made, we bind ourselves, our heirs, executors, administrators, successors, and assigns, jointly and severally, firmly by these presents.

WHEREAS, said Principal has submitted a Bid to said OWNER to perform the WORK required under the Bid Schedule of the OWNER's Contract Documents entitled

WRANGELL MARINE SERVICE CENTER – BOAT HAULOUT PIER STRUCTURAL UPGRADES

NOW THEREFORE, if said Principal is awarded a contract by said OWNER and, within the time and in the manner required in the "Notice Inviting Bids" and the "Instructions to Bidders" enters into a written Agreement on the form of Agreement bound with said Contract Documents, furnishes the required certificates of insurance, and furnishes the required Performance Bond and Payment Bond, then this obligation shall be null and void, otherwise it shall remain in full force and effect. In the event suit is brought upon this bond by said OWNER and OWNER prevails, said Surety shall pay all costs incurred by said OWNER in such suit, including a reasonable attorney's fee to be fixed by the court.

SIGNED AND SEALED, this _____ day of _____, 20____

(SEAL) _____
(Principal)

(SEAL) _____
(Surety)

By: _____
(Signature)

By: _____
(Signature)

SECTION 00360 - SUBCONTRACTOR REPORT

LIST OF SUBCONTRACTORS

The apparent low Bidder must submit a list of Subcontractors that the Bidder proposes to use in the performance of this contract and all Subcontractor Sales Tax Forms by close of business on the fifth calendar day following the posting notice of Bids. If the fifth calendar day falls on a weekend or holiday, the report is due by close of business on the next business day following the weekend or holiday. The list must include each Subcontractor's name, address, location, evidence of valid Alaska Business License, and valid Alaska Contractor's Registration under AS 08.18. *If no Subcontractors are to be utilized in the performance of the WORK, write in ink or type "NONE" on line (1) below.*

<u>SUBCONTRACTOR</u>	¹ AK Contractor <u>License No.</u>	¹ <u>Contact Name</u>	<u>Type of</u>	<u>Contract</u>	<input type="checkbox"/>
<u>ADDRESS</u>	² AK Business <u>License No.</u>	² <u>Phone No.</u>	<u>Work</u>	<u>Amount</u>	<input type="checkbox"/> [√] if <u>DBE</u>
1. _____ _____ _____	1 _____ 2 _____	_____	_____	\$ _____	<input type="checkbox"/>
2. _____ _____ _____	1 _____ 2 _____	_____	_____	\$ _____	<input type="checkbox"/>
3. _____ _____ _____	1 _____ 2 _____	_____	_____	\$ _____	<input type="checkbox"/>
4. _____ _____ _____	1 _____ 2 _____	_____	_____	\$ _____	<input type="checkbox"/>

I certify that the above listed Alaska Business License(s) and CONTRACTOR Registration(s), if applicable, were valid at the time Bids were opened for this Project.

CONTRACTOR, Authorized Signature

CONTRACTOR, Printed Name

A. A Bidder may replace a listed Subcontractor if the Subcontractor:

SECTION 00360 - SUBCONTRACTOR REPORT

1. fails to comply with AS 08.18;
 2. files for bankruptcy or becomes insolvent;
 3. fails to execute a contract with the Bidder involving performance of the WORK for which the Subcontractor was listed and the Bidder acted in good faith;
 4. fails to obtain bonding;
 5. fails to obtain insurance acceptable to the OWNER;
 6. fails to perform the contract with the Bidder involving work for which the Subcontractor was listed;
 7. must be substituted in order for the CONTRACTOR to satisfy required state and federal affirmative action requirements;
 8. refuses to agree or abide with the Bidder's labor agreement; or
 9. is determined by the OWNER not to be a responsible Bidder.
- B. If a Bidder fails to list a Subcontractor or lists more than one Subcontractor for the same portion of WORK, the Bidder shall be considered to have agreed to perform that portion of WORK without the use of a Subcontractor and to have represented the Bidder to be qualified to perform that WORK.
- C. A Bidder who attempts to circumvent the requirements of this section by listing as a Subcontractor another contractor who, in turn, sublets the majority of the WORK required under the contract violates this section.
- D. If a contract is awarded to a Bidder who violates this section, the OWNER may:
1. cancel the contract; or
 2. after notice and a hearing, assess a penalty on the Bidder in an amount that does not exceed 10 percent of the value of the subcontract at issue.
- E. For contract award, the apparent low Bidder must submit one copy of each subcontract, to the Project Manager, for WORK with a value of greater than one half of one percent of the intended award amount.
- F. An apparent low Bidder who fails to submit a completed Subcontractor Report within the time specified in this section will be found to be not a responsible Bidder and may be required to forfeit the Bid security. The OWNER will then consider the next lowest Bidder for award of the contract.

END OF SECTION

SECTION 00500 - AGREEMENT

THIS AGREEMENT is between THE CITY AND BOROUGH OF WRANGELL (hereinafter called OWNER) and _____ (hereinafter called CONTRACTOR) OWNER and CONTRACTOR, in consideration of the mutual covenants hereinafter set forth, agree as follows:

ARTICLE 1. WORK.

CONTRACTOR shall complete the WORK as specified or as indicated under the Bid Schedule of the OWNER’S Contract Documents entitled.

WRANGELL MARINE SERVICE CENTER – BOAT HAULOUT PIER STRUCTURAL UPGRADES

The WORK consists of all activities necessary to construct the Wrangell Marine Service Center Boat Haulout Pier Structural Upgrades as shown in the contract documents. Work includes strengthening the concrete deck from below by installing steel beams and grouting between the beams and the concrete deck and miscellaneous appurtenant work items.

ARTICLE 2. CONTRACT COMPLETION TIME.

The WORK completion schedule is: The OWNER will open the site to the CONTRACTOR concurrently with the **Notice to Proceed**. The contract completion times shall be in accordance with the table as follows:

DESCRIPTION (ITEM)	EARLIEST START (DATE)	SUBSTANTIAL COMPLETION (DATE)
SUBSTANTIAL COMPLETION	NOTICE TO PROCEED (NTP)	October 1, 2013
FINAL COMPLETION		November 1, 2013

ARTICLE 3. DATE OF AGREEMENT

The date of this Agreement will be the date of the last signature on page three of this section.

ARTICLE 4. LIQUIDATED DAMAGES.

OWNER and the CONTRACTOR recognize that time is of the essence of this Agreement and that the OWNER will suffer financial loss if the WORK is not completed within the time specified in Article 2 herein, plus any extensions thereof allowed in accordance with Article 12 of the General Conditions. They also recognize the delays, expense, and difficulties involved in proving in a legal proceeding the actual damages suffered by the OWNER if the WORK is not completed on time. Accordingly, instead of requiring any such proof, the OWNER and the CONTRACTOR agree that as liquidated damages for delay (but not as a penalty) the CONTRACTOR shall pay the OWNER \$1,500.00 for each Calendar Day that expires after the Substantial Completion time specified in Article 2 herein. The amount of liquidated damages specified above is agreed to be a reasonable estimate based on all facts known as of the date of this Agreement.

ARTICLE 5. CONTRACT PRICE.

OWNER shall pay CONTRACTOR for completion of the WORK in accordance with the Contract Documents in the amount set forth in the Bid Schedule. The CONTRACTOR agrees to accept as full and complete

SECTION 00500 - AGREEMENT

payment for all WORK to be done in this contract for: **WRANGELL MARINE SERVICE CENTER – BOAT HAULOUT PIER STRUCTURAL UPGRADES** those Unit Price amounts as set forth in the Bid Schedule in the Contract Documents for this Project.

The total amount of this contract shall be _____ (\$ _____), except as adjusted in accordance with the provisions of the Contract Documents.

ARTICLE 6. PAYMENT PROCEDURES.

CONTRACTOR shall submit Applications for Payment in accordance with Article 14 of the General Conditions. Applications for Payment will be processed by the ENGINEER as provided in the General Conditions.

Progress payments will be paid in full in accordance with Article 14 of the General Conditions until ninety (90) percent of the Contract Price has been paid. The remaining ten (10) percent of the Contract Price may be retained, in accordance with applicable Alaska State Statutes, until final inspection, completion, and acceptance of the Project by the OWNER.

ARTICLE 7. CONTRACT DOCUMENTS.

The Contract Documents which comprise the entire Agreement between OWNER and CONTRACTOR concerning the WORK consist of this Agreement (pages 00500-1 to 00500-6, inclusive) and the following sections of the Contract Documents:

- Table of Contents (pages 00005-1 to 00005-3, inclusive)
- Notice Inviting Bids (pages 00030-1 to 00030-2, inclusive).
- Instructions to Bidders (pages 00100-1 to 00100-7, inclusive).
- Bid (pages 00300-1 to 00300-2, inclusive).
- Bid Schedule (page 00310-1, inclusive).
- Bid Bond (page 00320-1, inclusive) or Bid Security.
- Subcontractor Report (pages 00360-1 to 00360-2, inclusive).
- Performance Bond (pages 00610-1 to 00610-2, inclusive).
- Payment Bond (pages 00620-1 to 00620-2, inclusive).
- Insurance Certificate(s).
- General Conditions (pages 00700-1 to 00700-46, inclusive).
- Supplementary General Conditions (pages 00800-1 to 00800-3, inclusive).
- Labor Standards, Reporting, and Prevailing Wage Determination (pages 00830-1 and 00840-1).
- Permits (page 00852-2 and all inclusive documents).
- Technical Specifications as listed in the Table of Contents.
- Drawings consisting of 9 sheets, as listed in the Table of Contents.
- Addenda numbers _____ to _____, inclusive.
- Change Orders which may be delivered or issued after the Date of the Agreement and which are not attached hereto.

There are no Contract Documents other than those listed in this Article 7. The Contract Documents may only be amended by Change Order as provided in Paragraph 3.3 of the General Conditions.

ARTICLE 8. MISCELLANEOUS.

Terms used in this Agreement which are defined in Article 1 of the General Conditions will have the meanings

SECTION 00500 - AGREEMENT

indicated in the General Conditions.

No assignment by a party hereto of any rights under or interests in the Contract Documents will be binding on another party hereto without the written consent of the party sought to be bound; and specifically but without limitation monies that may become due and monies that are due may not be assigned without such consent (except to the extent that the effect of this restriction may be limited by law), and unless specifically stated to

the contrary in any written consent to an assignment, no assignment will release or discharge the assignor from any duty or responsibility under the Contract Documents.

OWNER and CONTRACTOR each binds itself, its partners, successors, assigns and legal representatives to the other party hereto, its partners, successors, assigns and legal representatives in respect of all covenants, agreements and obligations contained in the Contract Documents. This Agreement shall be governed by the laws of the State of Alaska. Jurisdiction shall be in the State of Alaska, First Judicial District.

IN WITNESS WHEREOF, OWNER and CONTRACTOR have caused this Agreement to be executed on the date listed below by OWNER.

OWNER:

CONTRACTOR:

_____ City and Borough of Wrangell

(Company Name)

_____ (Signature)

_____ (Signature)

By: _____ (Printed Name)

By: _____ (Printed Name, Authority or Title)

Date: _____

Date: _____

OWNER's address for giving notices:

CONTRACTOR's address for giving notices:

_____ PO BOX 531

_____ Wrangell, Alaska 99929

_____ 907-874-2381 907-874-3952
(Telephone) (Fax)

_____ (Telephone) (Fax)

_____ (E-mail address)

Contractor License No. _____

SECTION 00500 - AGREEMENT

**CERTIFICATE
(if Corporation)**

STATE OF)
) SS:
COUNTY OF)

I HEREBY CERTIFY that a meeting of the Board of Directors of the
_____ a corporation existing under the laws of
the State of _____, held on _____, 20____, the following resolution
was duly passed and adopted:

“RESOLVED, that _____, as _____ President
of the Corporation, be and is hereby authorized to **execute the Agreement** with the CITY AND
BOROUGH OF WRANGELL and this corporation and that the execution thereof, attested by the
Secretary of the Corporation, and with the Corporate Seal affixed, shall be the official act and deed
of this Corporation.”

I further certify that said resolution is now in full force and effect.

IN WITNESS WHEREOF, I have hereunto set my hand and affixed the official seal of the
corporation this _____ day of _____, 20____.

Secretary

(SEAL)

SECTION 00500 - AGREEMENT

CERTIFICATE
(if Partnership)

STATE OF)
) SS:
COUNTY OF)

I HEREBY CERTIFY that a meeting of the Partners of the
_____ a partnership existing under the laws of the State
of _____, held on _____, 20____, the following resolution was duly
passed and adopted:

"RESOLVED, that _____, as _____ of the Partnership, be and is
hereby authorized to **execute the Agreement** with the CITY AND BOROUGH OF WRANGELL
and this partnership and that the execution thereof, attested by the _____ shall
be the official act and deed of this Partnership."

I further certify that said resolution is now in full force and effect.

IN WITNESS WHEREOF, I have hereunto set my hand this _____, day of _____,
20_____.

Secretary

(SEAL)

SECTION 00500 - AGREEMENT

CERTIFICATE
(if Joint Venture)

STATE OF)
) SS:
COUNTY OF)

I HEREBY CERTIFY that a meeting of the Principals of the

_____ a joint venture existing under the laws of the

State of _____, held on _____, 20 ____, the following resolution was duly passed and adopted:

"RESOLVED, that _____, as _____ of the Joint Venture, be and is hereby authorized to **execute the Agreement** with the CITY AND BOROUGH OF WRANGELL and this joint venture and that the execution thereof, attested by the _____ shall be the official act and deed of this Joint Venture."

I further certify that said resolution is now in full force and effect.

IN WITNESS WHEREOF, I have hereunto set my hand this _____, day of _____, 20____.

Secretary

(SEAL)

SECTION 00610 - PERFORMANCE BOND

KNOW ALL PERSONS BY THESE PRESENTS: That we _____
(Name of Contractor)

_____ a _____
(Corporation, Partnership, Individual)

hereinafter called "Principal" and _____
(Surety)

of _____, State of _____ hereinafter called the "Surety," are held and
firmly bound to the City and Borough of Wrangell, Alaska hereinafter called "OWNER,"
(Owner) (City and State)

for the penal sum of _____

_____ dollars (\$ _____) in lawful money of the
United States, for the payment of which sum well and truly to be made, we bind ourselves, our heirs, executors,
administrators and successors, jointly and severally, firmly by these presents.

THE CONDITION OF THIS OBLIGATION is such that whereas, the CONTRACTOR has entered
into a certain contract with the OWNER, the effective date of which is _____, a copy
of which is hereto attached and made a part hereof for the construction of:

**WRANGELL MARINE SERVICE CENTER – BOAT HAULOUT PIER STRUCTURAL
UPGRADES**

NOW, THEREFORE, if the Principal shall truly and faithfully perform its duties, all the undertakings,
covenants, terms, conditions, and agreements of said contract during the original term thereof, and any
extensions thereof, which may be granted by the OWNER, with or without notice to the Surety, and if it shall
satisfy all claims and demands incurred under such contract, and shall fully indemnify and save harmless the
OWNER from all costs and damages which it may suffer by reason of failure to do so, and shall reimburse and
repay the OWNER all outlay and expense which the OWNER may incur in making good any default, then this
obligation shall be void; otherwise to remain in full force and effect.

PROVIDED, FURTHER, that the said Surety, for value received hereby stipulates and agrees that no
change, extension of time, alteration or addition to the terms of the contract or to the WORK to be performed
thereunder or the specifications accompanying the same shall in any wise affect its obligation on this bond, and
it does hereby waive notice of any such change, extension of time, alteration or addition to the terms of the
contract or to the WORK or to the Specifications.

PROVIDED, FURTHER, that no final settlement between the OWNER and the Principal shall abridge
the right of any beneficiary hereunder, whose claim may be unsatisfied.

SECTION 00610 - PERFORMANCE BOND

WRANGELL MARINE SERVICE CENTER – BOAT HAULOUT PIER STRUCTURAL UPGRADES

IN WITNESS WHEREOF, this instrument is issued in two (2) identical counterparts, each one of which shall be deemed an original.

CONTRACTOR:

By: _____
(Signature)

(Printed Name)

(Company Name)

(Street or P.O. Box)

(City, State, Zip Code)

SURETY:

By: _____
(Signature of Attorney-in-Fact)

Date Issued: _____

(Printed Name)

(Company Name)

(Street or P.O. Box)

(City, State, Zip Code)

(Affix SURETY'S SEAL)

NOTE: If CONTRACTOR is Partnership, all Partners must execute bond.

SECTION 00620 - PAYMENT BOND

KNOW ALL PERSONS BY THESE PRESENTS: That we _____
(Name of Contractor)

_____ a _____
(Corporation, Partnership, Individual)

hereinafter called "Principal" and _____
(Surety)

of _____, State of _____ hereinafter called the "Surety," are held and
firmly bound to the City and Borough Of Wrangell, Alaska hereinafter called "OWNER,"
(Owner) (City and State)

for the penal sum of _____

_____ dollars (\$ _____) in lawful money of the
United States, for the payment of which sum well and truly to be made, we bind ourselves, our heirs, executors,
administrators and successors, jointly and severally, firmly by these presents.

THE CONDITION OF THIS OBLIGATION is such that whereas, the CONTRACTOR has entered
into a certain contract with the OWNER, the effective date of which is _____, a copy
of which is hereto attached and made a part hereof for the construction of:

**WRANGELL MARINE SERVICE CENTER – BOAT HAULOUT PIER STRUCTURAL
UPGRADES**

NOW, THEREFORE, if the Principal shall promptly make payment to all persons, firms,
Subcontractors, and corporations furnishing materials for, or performing labor in the prosecution of the WORK
provided for in such contract, and any authorized extension or modification thereof, including all amounts due
for materials, lubricants, oil, gasoline, coal and coke, repairs on machinery, equipment and tools, consumed or
used in connection with the construction of such WORK, and all insurance premiums on said work, and for all
labor performed in such WORK, whether by Subcontractor or otherwise, then this obligation shall be void;
otherwise to remain in full force and effect.

PROVIDED, FURTHER, that the said Surety, for value received hereby stipulates and agrees that no
change, extension of time, alteration or addition to the terms of the contract or to the work to be performed
thereunder or the specifications accompanying the same shall in any wise affect its obligation on this bond, and
it does hereby waive notice of any such change, extension of time, alteration or addition to the terms of the
contract or to the WORK or to the Specifications.

PROVIDED, FURTHER, that no final settlement between the OWNER and the Principal shall abridge
the right of any beneficiary hereunder, whose claim may be unsatisfied.

SECTION 00620 - PAYMENT BOND

WRANGELL MARINE SERVICE CENTER – BOAT HAULOUT PIER STRUCTURAL UPGRADES

IN WITNESS WHEREOF, this instrument is issued in two (2) identical counterparts, each one of which shall be deemed an original.

CONTRACTOR:

By: _____
(Signature)

(Printed Name)

(Company Name)

(Street or P.O. Box)

(City, State, Zip Code)

SURETY:

By: _____
(Signature of Attorney-in-Fact)

Date Issued: _____

(Printed Name)

(Company Name)

(Street or P.O. Box)

(City, State, Zip Code)

(Affix SURETY'S SEAL)

NOTE: If CONTRACTOR is Partnership, all Partners must execute bond.

SECTION 00700 - GENERAL CONDITIONS

TABLE OF CONTENTS

ARTICLE 1 DEFINITIONS 00700-5

ARTICLE 2 PRELIMINARY MATTERS

2.1 Delivery of Bonds/Insurance Certificates 00700-9
2.2 Copies of Documents 00700-9
2.3 Commencement of Contract Time; Notice to Proceed 00700-9
2.4 Starting the WORK 00700-9
2.5 Pre-construction Conference 00700-9

ARTICLE 3 CONTRACT DOCUMENTS: INTENT, AMENDING, REUSE

3.1 Intent 00700-9
3.2 Order of Precedence of Contract Documents 00700-10
3.3 Amending and Supplementing Contract Documents..... 00700-10
3.4 Reuse of Documents..... 00700-11

ARTICLE 4 AVAILABILITY OF LANDS; PHYSICAL CONDITIONS; REFERENCE POINTS

4.1 Availability of Lands 00700-11
4.2 Physical Conditions - Subsurface and Existing Structures 00700-11
4.3 Differing Site Conditions 00700-12
4.4 Physical Conditions - Underground Utilities 00700-12
4.5 Reference Points..... 00700-13

ARTICLE 5 BONDS AND INSURANCE

5.1 Performance, Payment and Other Bonds 00700-13
5.2 Insurance 00700-14

ARTICLE 6 CONTRACTOR'S RESPONSIBILITIES

6.1 Supervision and Superintendence..... 00700-15
6.2 Labor, Materials, and Equipment 00700-16
6.3 Adjusting Progress Schedule 00700-17
6.4 Substitutes or "Or Equal" Items..... 00700-17
6.5 Concerning Subcontractors, Suppliers and Others 00700-17
6.6 Permits..... 00700-19
6.7 Patent Fees and Royalties 00700-18
6.8 Laws and Regulations..... 00700-19

SECTION 00700 - GENERAL CONDITIONS

ARTICLE 6 CONTRACTOR'S RESPONSIBILITIES (Cont'd.)

6.9 Taxes 00700-19
6.10 Use of Premises 00700-19
6.11 Safety and Protection..... 00700-19
6.12 Shop Drawings and Samples 00700-20
6.13 Continuing the WORK..... 00700-21
6.14 Indemnification 00700-21
6.15 Contractor's Daily Reports..... 00700-22
6.16 Assignment of Contract..... 00700-22
6.17 Contractor's Responsibility for Utility Property and Services 00700-22
6.18 Operating Water System Valves 00700-22
6.19 CONTRACTOR's WORK Schedule Limitations 00700-22

ARTICLE 7 OTHER WORK

7.1 Related WORK at Site 00700-22
7.2 Coordination..... 00700-23

ARTICLE 8 OWNER'S RESPONSIBILITIES

8.1 Communications..... 00700-23
8.2 Payments 00700-23
8.3 Lands, Easements, and Surveys..... 00700-23
8.4 Change Orders..... 00700-23
8.5 Inspections and Tests..... 00700-24
8.6 Suspension of WORK 00700-24
8.7 Termination of Agreement 00700-24

ARTICLE 9 ENGINEER'S STATUS DURING CONSTRUCTION

9.1 OWNER 's Representative 00700-24
9.2 Visits to Site 00700-24
9.3 Project Representation..... 00700-24
9.4 Clarifications and Interpretations..... 00700-26
9.5 Authorized Variations in WORK 00700-26
9.6 Rejecting Defective WORK 00700-26
9.7 CONTRACTOR Submittals, Change Orders, and Payments 00700-26
9.8 Decisions on Disputes 00700-27
9.9 Limitation on Engineer's Responsibilities 00700-27

ARTICLE 10 CHANGES IN THE WORK

10.1 General 00700-28
10.2 Allowable Quantity Variations 00700-29

SECTION 00700 - GENERAL CONDITIONS

ARTICLE 11 CHANGE OF CONTRACT PRICE

11.1 General 00700-29
11.2 Costs Relating to Weather 00700-30
11.3 Cost of WORK (Based on Time and Materials)..... 00700-30
11.4 CONTRACTOR's Fee..... 00700-33
11.5 Excluded Costs..... 00700-35

ARTICLE 12 CHANGE OF CONTRACT TIME

12.1 General 00700-36
12.2 Extensions of Time for Delay Due to Weather..... 00700-36

**ARTICLE 13 WARRANTY AND GUARANTEE; TESTS AND INSPECTIONS;
CORRECTION, REMOVAL, OR ACCEPTANCE OF DEFECTIVE WORK**

13.1 Warranty and Guarantee..... 00700-35
13.2 Access to WORK 00700-35
13.3 Tests and Inspections..... 00700-35
13.4 OWNER May Stop the WORK..... 00700-36
13.5 Correction or Removal of Defective WORK..... 00700-37
13.6 One Year Correction Period 00700-37
13.7 Acceptance of Defective WORK..... 00700-37

ARTICLE 14 PAYMENTS TO CONTRACTOR AND COMPLETION

14.1 Schedule of Values (Lump Sum Price Breakdown) 00700-37
14.2 Unit Price Bid Schedule 00700-37
14.3 Application for Progress Payment 00700-38
14.4 CONTRACTOR's Warranty of Title 00700-38
14.5 Review of Applications for Progress Payment 00700-38
14.6 Partial Utilization 00700-39
14.7 Substantial Completion 00700-39
14.8 Final Application for Payment..... 00700-40
14.9 Final Payment and Acceptance..... 00700-40
14.10 Release of Retainage and Other Deductions..... 00700-40
14.11 CONTRACTOR's Continuing Obligation..... 00700-41
14.12 Final Payment Terminates Liability of OWNER 00700-41

ARTICLE 15 SUSPENSION OF WORK AND TERMINATION

15.1 Suspension of WORK by OWNER..... 00700-41
15.2 Termination of Agreement by OWNER (CONTRACTOR Default)..... 00700-41
15.3 Termination of Agreement by OWNER (For Convenience) 00700-42
15.4 Termination of Agreement by CONTRACTOR..... 00700-42

SECTION 00700 - GENERAL CONDITIONS

ARTICLE 16 MISCELLANEOUS

16.1 Giving Notice 00700-42
16.2 Rights In and Use of Materials Found on the WORK 00700-42
16.3 Right to Audit..... 00700-43
16.4 Archaeological or Historical Discoveries 00700-43
16.5 Construction Over or Adjacent to Navigable Waters 00700-44
16.6 Gratuity and Conflict of Interest..... 00700-44
16.7 Suits of Law Concerning the WORK..... 00700-44
16.8 Certified Payrolls..... 00700-44
16.9 Prevailing Wage Rates 00700-44
16.10 Employment Reference 00700-45
16.11 Cost Reduction Incentive 00700-45

SECTION 00700 - GENERAL CONDITIONS

ARTICLE 1 DEFINITIONS

Wherever used in these General Conditions or in the other Contract Documents the following terms have the meanings indicated which are applicable to both the singular and plural thereof. Where an entire word is capitalized in the definitions and is found not capitalized in the Contract Documents it has the ordinary dictionary definition.

Addenda - Written or graphic instruments issued prior to the opening of Bids which make additions, deletions, or revisions to the Contract Documents.

Agreement - The written contract between the OWNER and the CONTRACTOR covering the WORK to be performed; other documents are attached to the Agreement and made a part thereof as provided therein.

Application for Payment - The form furnished by the ENGINEER which is to be used by the CONTRACTOR to request progress or final payment and which is to be accompanied by such supporting documentation as is required by the Contract Documents.

Asbestos - Any material that contains more than one percent asbestos and is friable or is releasing asbestos fibers into the air above current action levels established by the United States Occupational Safety and Health Administration.

Bid - The offer or proposal of the Bidder submitted on the prescribed form setting forth the price or prices for the WORK.

Bonds - Bid, Performance, and Payment Bonds and other instruments which protect against loss due to inability or refusal of the CONTRACTOR to perform its contract.

City and Borough of Wrangell Project Manager - The authorized representative of the City and Borough of Wrangell, as OWNER, who is responsible for administration of the contract.

Change Order - A document recommended by the ENGINEER, which is signed by the CONTRACTOR and the OWNER and authorizes an addition, deletion, or revision in the WORK, or an adjustment in the Contract Price or the Contract Time, issued on or after the Effective Date of the Agreement.

Contract Documents - The Table of Contents, Notice Inviting Bids, Instructions to Bidders, Bid Forms (including the Bid, Bid Schedule(s), Information Required of Bidder, Bid Bond, and all required certificates and affidavits), Agreement, Performance Bond, Payment Bond, General Conditions, Supplementary General Conditions, Technical Specifications, Drawings, Permits, and all Addenda, and Change Orders executed pursuant to the provisions of the Contract Documents.

Contract Price - The total monies payable by the OWNER to the CONTRACTOR under the terms and conditions of the Contract Documents.

Contract Time - The number of successive calendar days stated in the Contract Documents for the completion of the WORK.

CONTRACTOR - The individual, partnership, corporation, joint-venture or other legal entity with whom the OWNER has executed the Agreement.

SECTION 00700 - GENERAL CONDITIONS

Day - A calendar day of 24 hours measured from midnight to the next midnight.

Defective WORK - WORK that is unsatisfactory, faulty, or deficient; or that does not conform to the Contract Documents; or that does not meet the requirements of any inspection, reference standard, test, or approval referred to in the Contract Documents; or WORK that has been damaged prior to the ENGINEER's recommendation of final payment.

Drawings - The Drawings, plans, maps, profiles, diagrams, and other graphic representations which indicate the character, location, nature, extent, and scope of the WORK and which have been prepared by the ENGINEER and are referred to in the Contract Documents. Shop Drawings are not within the meaning of this paragraph.

Effective Date of the Agreement - The date indicated in the Agreement on which it becomes effective, but if no such date is indicated it means the date on which the Agreement is signed and delivered by the last of the two parties to sign and deliver.

Engineer of Record - The individual, partnership, corporation, joint-venture or other legal entity named as such in the Contract Documents.

ENGINEER - The ENGINEER is the firm or person(s) selected by the City and Borough of Wrangell to perform the duties of project inspection and management. The City and Borough of Wrangell will inform the CONTRACTOR of the identity of the ENGINEER at or before the Notice to Proceed.

Field Order - A written order issued by the ENGINEER which may or may not involve a change in the WORK.

General Requirements - Division 1 of the Technical Specifications.

Hazardous Waste - The term Hazardous Waste shall have the meaning provided in Section 1004 of the Solid Waste Disposal Act (42 USC Section 9603) as amended from time to time.

Holidays - The City and Borough of Wrangell legal holidays occur on:

1. New Year's Day - January 1
2. Martin Luther King's Birthday - Third Monday in January
3. President's Day - Third Monday in February
4. Seward's Day - Last Monday in March
5. Memorial Day - Last Monday in May
6. Independence Day - July 4
7. Labor Day - First Monday in September
8. Alaska Day - October 18
9. Veteran's Day - November 11
10. Thanksgiving Day - Fourth Thursday and the following Friday in November
11. Christmas Day - December 25

If any holiday listed above falls on a Saturday, Saturday and the preceding Friday are both legal holidays. If the holiday should fall on a Sunday, Sunday and the following Monday are both legal holidays.

SECTION 00700 - GENERAL CONDITIONS

Inspector - The authorized representative of the ENGINEER assigned to make detailed inspections for conformance to the Contract Documents. Any reference to the Resident Project Representative in this document shall mean the Inspector.

Laws and Regulations; Laws or Regulations - Any and all applicable laws, rules, regulations, ordinances, codes, and/or orders of any and all governmental bodies, agencies, authorities and courts having jurisdiction.

Mechanic's Lien - A form of security, an interest in real property, which is held to secure the payment of an obligation. When referred to in these Contract Documents, "Mechanic's Lien" or "lien" means "Stop Notice".

Milestone - A principal event specified in the Contract Documents relating to an intermediate completion date of a portion of the WORK, or a period of time within which the portion of the WORK should be performed prior to Substantial Completion of all the WORK.

Notice of Intent to Award - The written notice by the OWNER to the apparent successful bidder stating that upon compliance by the apparent successful bidder with the requirements listed therein, within the time specified, the OWNER will enter into an Agreement.

Notice of Award - The written notice by the OWNER to the apparent successful bidder stating that the apparent successful bidder has complied with all conditions for award of the contract.

Notice of Completion - A form signed by the ENGINEER and the CONTRACTOR recommending to the OWNER that the WORK is Substantially Complete and fixing the date of Substantial Completion. After acceptance of the WORK by the OWNER's governing body, the form is signed by the OWNER and filed with the County Recorder. This filing starts the 30 day lien filing period on the WORK.

Notice to Proceed - The written notice issued by the OWNER to the CONTRACTOR authorizing the CONTRACTOR to proceed with the WORK and establishing the date of commencement of the Contract Time.

OWNER – The City and Borough of Wrangell, acting through its legally designated officials, officers, or employees.

Partial Utilization - Use by the OWNER or a substantially completed part of the WORK for the purpose for which it is intended prior to Substantial Completion of all the WORK.

PCB's - Polychlorinated biphenyls.

PERMITTEE – CONTRACTOR.

Petroleum - Petroleum, including crude oil or any fraction thereof which is liquid at standard conditions of temperature and pressure (60 degrees Fahrenheit and 14.7 pounds per square inch absolute), such as oil, petroleum, fuel oil, oil sludge, oil refuse, gasoline, kerosene, and oil mixed with other non-Hazardous Wastes and crude oils.

Project - The total construction of which the WORK to be provided under the Contract Documents may be the whole, or a part as indicated elsewhere in the Contract Documents.

SECTION 00700 - GENERAL CONDITIONS

Radioactive Material - Source, special nuclear, or byproduct material as defined by the Atomic Energy Act of 1954 (42 USC Section 2011 et seq.) as amended from time to time.

Shop Drawings - All Drawings, diagrams, illustrations, schedules and other data which are specifically prepared by or for the CONTRACTOR and submitted by the CONTRACTOR, to the ENGINEER, to illustrate some portion of WORK.

Specifications - (Same definition as for Technical Specifications hereinafter).

Stop Notice - A legal remedy for Subcontractors and suppliers who contribute to public works, but who are not paid for their WORK, which secures payment from construction funds possessed by the OWNER. For public property, the Stop Notice remedy is designed to substitute for mechanic's lien rights.

Sub-Consultant - The individual, partnership, corporation, joint-venture or other legal entity having a direct contract with ENGINEER, or with any of its Consultants to furnish services with respect to the Project.

Subcontractor - An individual, partnership, corporation, joint-venture or other legal entity having a direct contract with the CONTRACTOR, or with any of its Subcontractors, for the performance of a part of the WORK at the site.

Substantial Completion - Refers to when the WORK has progressed to the point where, in the opinion of the ENGINEER as evidenced by Notice of Completion as applicable, it is sufficiently complete, in accordance with the Contract Documents, so that the WORK can be utilized for the purposes for which it is intended; or if no such notice is issued, when final payment is due in accordance with Paragraph 14.8. The terms "substantially complete" and "substantially completed" as applied to any WORK refer to substantial completion thereof.

Supplementary General Conditions (SGC) - The part of the Contract Documents which make additions, deletions, or revisions to these General Conditions.

Supplier - A manufacturer, fabricator, supplier, distributor, materialman, or vendor.

Technical Specifications - Divisions 1 through 16 of the Contract Documents consisting of the General Requirements and written technical descriptions of products and execution of the WORK.

Underground Utilities - All pipelines, conduits, ducts, cables, wires, manholes, vaults, tanks, tunnels, or other such facilities or attachments, and any encasements containing such facilities which have been installed underground to furnish any of the following services or materials: water, sewage and drainage removal, electricity, gases, steam, liquid petroleum products, telephone or other communications, cable television, traffic, or other control systems.

WORK - The entire completed construction or the various separately identifiable parts thereof required to be furnished under the Contract Documents. WORK is the result of performing, or furnishing labor and furnishing and incorporating materials and equipment into the construction, and performing or furnishing services and furnishing documents, all as required by the Contract Documents.

SECTION 00700 - GENERAL CONDITIONS

ARTICLE 2 PRELIMINARY MATTERS

- 2.1 DELIVERY OF BONDS/INSURANCE CERTIFICATES. When the CONTRACTOR delivers the signed Agreements to the OWNER, the CONTRACTOR shall also deliver to the OWNER such Bonds and Insurance Policies and Certificates as the CONTRACTOR may be required to furnish in accordance with the Contract Documents.
- 2.2 COPIES OF DOCUMENTS. The OWNER shall furnish to the CONTRACTOR the required number of copies of the Contract Documents specified in the Supplementary General Conditions.
- 2.3 COMMENCEMENT OF CONTRACT TIME; NOTICE TO PROCEED. The Contract Time will start to run on the commencement date stated in the Notice to Proceed.
- 2.4 STARTING THE WORK
- A. The CONTRACTOR shall begin to perform the WORK within 10 days after the commencement date stated in the Notice to Proceed, but no WORK shall be done at the site prior to said commencement date.
 - B. Before undertaking each part of the WORK, the CONTRACTOR shall carefully study and compare the Contract Documents and check and verify pertinent figures shown thereon and all applicable field measurements. The CONTRACTOR shall promptly report in writing to the ENGINEER any conflict, error, or discrepancy which the CONTRACTOR may discover and shall obtain a written interpretation or clarification from the ENGINEER before proceeding with any WORK affected thereby.
 - C. The CONTRACTOR shall submit to the ENGINEER for review those documents called for under Section 01300 - CONTRACTOR Submittals in the General Requirements.
- 2.5 PRE-CONSTRUCTION CONFERENCE. The CONTRACTOR is required to attend a Pre-Construction Conference. This conference will be attended by the ENGINEER and others as appropriate in order to discuss the WORK in accordance with the applicable procedures specified in the General Requirements, Section 01010 - Summary of WORK in the General Requirements.

ARTICLE 3 CONTRACT DOCUMENTS: INTENT, AMENDING, REUSE

- 3.1 INTENT
- A. The Contract Documents comprise the entire Agreement between the OWNER and the CONTRACTOR concerning the WORK. The Contract Documents shall be construed as a whole in accordance with Alaska Law.
 - B. It is the intent of the Contract Documents to describe the WORK, functionally complete, to be constructed in accordance with the Contract Documents. Any work, materials, or equipment that may reasonably be inferred from the Contract Documents as being required to produce the intended result shall be supplied whether or not specifically called for. When words or phrases which have a well-known technical or construction industry or trade meaning are used to describe work, materials, or equipment such words or phrases shall be interpreted in

SECTION 00700 - GENERAL CONDITIONS

accordance with that meaning, unless a definition has been provided in Article 1 of the General Conditions. Reference to standard specifications, manuals, or codes of any technical society, organization, or association, or to the Laws or Regulations of any governmental authority, whether such reference be specific or by implication, shall mean the latest standard specification, manual, code, or Laws or Regulations in effect at the time of opening of Bids, except as may be otherwise specifically stated. However, no provision of any referenced standard specification, manual, or code (whether or not specifically incorporated by reference in the Contract Documents) shall be effective to change the duties and responsibilities of the OWNER, the CONTRACTOR, or the ENGINEER or any of their consultants, agents, or employees from those set forth in the Contract Documents.

- C. If, during the performance of the WORK, CONTRACTOR discovers any conflict, error, ambiguity or discrepancy within the Contract Documents or between the Contract Documents and any provision of any such Law or Regulation applicable to the performance of the WORK or of any such standard, specification, manual or code or of any instruction of any Supplier referred to in paragraph 6.5, the CONTRACTOR shall report it to the ENGINEER in writing at once, and the CONTRACTOR shall not proceed with the WORK affected thereby (except in an emergency as authorized by the ENGINEER) until a clarification field order, or Change Order to the Contract Documents has been issued.

3.2 ORDER OF PRECEDENCE OF CONTRACT DOCUMENTS

- A. In resolving conflicts resulting from, errors, or discrepancies in any of the Contract Documents, the order of precedence shall be as follows:
 - 1. Permits from other agencies as may be required by law, excepting the definition of "PERMITEE" in these permits.
 - 2. Field Orders
 - 3. Change Orders
 - 4. ENGINEER's written interpretations and clarifications.
 - 5. Agreement
 - 6. Addenda
 - 7. CONTRACTOR's Bid (Bid Form)
 - 8. Notice Inviting Bids
 - 9. Instructions to Bidders
 - 10. General Conditions
 - 11. Technical Specifications
 - 12. Drawings
- B. With reference to the Drawings the order of precedence is as follows:
 - 1. Figures govern over scaled dimensions
 - 2. Detail Drawings govern over general Drawings
 - 3. Addenda/ Change Order drawings govern over Contract Drawings
 - 4. Contract Drawings govern over standard drawings

- 3.3 AMENDING AND SUPPLEMENTING CONTRACT DOCUMENTS. The Contract Documents may be amended to provide for additions, deletions, and revisions in the WORK or to modify the terms and conditions thereof by a Change Order (pursuant to Article 10 CHANGES IN THE WORK).

SECTION 00700 - GENERAL CONDITIONS

- 3.4 REUSE OF DOCUMENTS. Neither the CONTRACTOR, nor any Subcontractor or Supplier, nor any other person or organization performing any of the WORK under a contract with the OWNER shall have or acquire any title to or ownership rights in any of the Drawings, Technical Specifications, or other documents used on the WORK, and they shall not reuse any of them on the extensions of the Project or any other project without written consent of the OWNER.

ARTICLE 4 AVAILABILITY OF LANDS; PHYSICAL CONDITIONS; REFERENCE POINTS

- 4.1 AVAILABILITY OF LANDS. The OWNER shall furnish, as indicated in the Contract Documents, the lands upon which the WORK is to be performed, rights-of-way and easements for access thereto, and such other lands which are designated for the use of the CONTRACTOR. Easements for permanent structures or permanent changes in existing facilities will be obtained and paid for by the OWNER, unless otherwise provided in the Contract Documents. Nothing contained in the Contract Documents shall be interpreted as giving the CONTRACTOR exclusive occupancy of the lands or rights-of-way provided. The CONTRACTOR shall provide for all additional lands and access thereto that may be required for temporary construction facilities or storage of materials and equipment; provided, that the CONTRACTOR shall not enter upon nor use any property not under the control of the OWNER until a written temporary construction easement, lease or other appropriate agreement has been executed by the CONTRACTOR and the property owner, and a copy of said agreement furnished to the ENGINEER prior to said use; and, neither the OWNER nor the ENGINEER shall be liable for any claims or damages resulting from the CONTRACTOR's unauthorized trespass or use of any such properties.
- 4.2 PHYSICAL CONDITIONS - SUBSURFACE AND EXISTING STRUCTURES
- A. Explorations and Reports. Reference is made to SGC 4.2 Physical Conditions of the Supplementary General Conditions for identification of those reports of explorations and tests of sub-surface conditions at the site that have been utilized by the ENGINEER in the preparation of the Contract Documents. The CONTRACTOR may rely upon the accuracy of the technical data contained in such reports, however, reports are not to be considered complete or comprehensive and nontechnical data, interpretations, and opinions contained in such reports are not to be relied on by the CONTRACTOR. The CONTRACTOR is responsible for any further explorations or tests that may be necessary and any interpretation, interpolation, or extrapolation that it makes of any information shown in such reports.
- B. Existing Structures. Reference is made to SGC 4.2 Physical Conditions of the Supplementary General Conditions for identification of those drawings of physical conditions in or relating to existing surface and subsurface structures (except Underground Utilities referred to in Paragraph 4.4 herein) which are at or contiguous to the site that have been utilized by the ENGINEER in the preparation of the Contract Documents. The CONTRACTOR may rely upon the accuracy of the technical data contained in such drawings, however, nontechnical data, interpretations, and opinions contained in such drawings are not to be relied on by the CONTRACTOR. The CONTRACTOR is also responsible for any interpretation, interpolation, or extrapolation that it makes of any information shown in such drawings.

SECTION 00700 - GENERAL CONDITIONS

4.3 DIFFERING SITE CONDITIONS

- A. The CONTRACTOR shall promptly upon discovery (but in no event later than 14 days thereafter) and before the following conditions are disturbed, notify the ENGINEER, in writing of any:
1. Material that the CONTRACTOR believes may be material that is hazardous waste, as defined in Article 1 of these General Conditions, or asbestos, PCB's, petroleum or any other substance or material posing a threat to human or to the environment.
 2. Subsurface or latent physical conditions at the site differing from those indicated.
 3. Unknown physical conditions at the site of any unusual nature, different materially from those ordinarily encountered and generally recognized as inherent in WORK of the character provided for in the contract.
- B. The OWNER shall promptly investigate the conditions, and if it finds that the conditions do materially so differ, or do involve hazardous waste, and cause a decrease or increase in the CONTRACTOR's cost of, or the time required for, performance of any part of the WORK shall issue a Change Order under the procedures described in the contract.
- C. In the event that a dispute arises between the OWNER and the CONTRACTOR whether the conditions materially differ, or involved hazardous waste or other materials listed above, or cause a decrease or increase in the CONTRACTOR's cost of, or time required for, performance of any part of the WORK, the CONTRACTOR shall not be excused from any scheduled completion date provided for by the contract, but shall proceed with all WORK to be performed under the contract. The CONTRACTOR shall retain any and all rights provided either by contract or by Law which pertain to the resolution of disputes and protests between the contracting parties.

4.4 PHYSICAL CONDITIONS - UNDERGROUND UTILITIES

- A. Indicated. The information and data indicated in the Contract Documents with respect to existing Underground Utilities at or contiguous to the site are based on information and data furnished to the OWNER or the ENGINEER by the owners of such Underground Utilities or by others. Unless it is expressly provided in the Supplementary General Conditions and/or Section 01530 - Protection and Restoration of Existing Facilities of the General Requirements, the OWNER and the ENGINEER shall not be responsible for the accuracy or completeness of any such information or data, and the CONTRACTOR shall have full responsibility for reviewing and checking all such information and data, for locating all Underground Utilities indicated in the Contract Documents, for coordination of the WORK with the owners of such Underground Utilities during construction, for the safety and protection thereof and repairing any damage thereto resulting from the WORK, the cost of which will be considered as having been included in the Contract Price.
- B. Not Indicated. If an Underground Utility is uncovered or revealed at or contiguous to the site which was not indicated in the Contract Documents and which the CONTRACTOR could not reasonably have been expected to be aware of, the CONTRACTOR shall identify the owner of such Underground Utility and give written notice thereof to that owner and shall notify the ENGINEER in accordance with the requirements of the Supplementary General Conditions

SECTION 00700 - GENERAL CONDITIONS

and Section 01530 - Protection and Restoration of Existing Facilities of the General Requirements.

4.5 REFERENCE POINTS

- A. The ENGINEER will provide one bench mark, near or on the site of the WORK, and will provide two points near or on the site to establish a base line for use by the CONTRACTOR for alignment control. Unless otherwise specified in the General Requirements, the CONTRACTOR shall furnish all other lines, grades, and bench marks required for proper execution of the WORK.
- B. The CONTRACTOR shall preserve all bench marks, stakes, and other survey marks, and in case of their removal or destruction by its own employees or by its Subcontractor's employees, the CONTRACTOR shall be responsible for the accurate replacement of such reference points by personnel qualified under the Alaska Statute governing the licensing of Architects, Engineers, and Land Surveyors.

ARTICLE 5 BONDS AND INSURANCE

5.1 PERFORMANCE, PAYMENT, AND OTHER BONDS

- A. The CONTRACTOR shall furnish, when required, Performance and Payment Bonds on forms provided by the City and Borough of Wrangell for the penal sums of 100% of the amount of the Bid award. The surety on each bond may be any corporation or partnership authorized to do business in the State of Alaska as an insurer under AS 21.09. These bonds shall remain in effect for 12 months after the date of final payment and until all obligations and liens under this contract have been satisfied. The CONTRACTOR shall also furnish such other Bonds as are required by the Supplementary General Conditions. All Bonds shall be in the form prescribed by the Contract Documents except as provided otherwise by Laws or Regulations, and shall be executed by such sureties as are named in the current list of "Companies Holding Certificates of Authority as Acceptable Sureties on Federal Bonds and as Acceptable Reinsuring Companies" as published in Circular 570 (amended) by the Audit Staff, Bureau of Government Financial Operations, U.S. Treasury Department. All Bonds signed by an agent must be accompanied by a certified copy of such agent's authority to act.
- B. If the surety on any Bond furnished by the CONTRACTOR is declared bankrupt or becomes insolvent or its right to do business is terminated in any state where any part of the WORK is located, the CONTRACTOR shall within 7 days thereafter substitute another Bond and Surety, which must be acceptable to the OWNER.
- C. All Bonds required by the Contract Documents to be purchased and maintained by CONTRACTOR shall be obtained from surety companies that are duly licensed or authorized in the State of Alaska to issue Bonds for the limits so required. Such surety companies shall also meet such additional requirements and qualifications as may be provided in the Supplementary General Conditions. The City Engineer may, on behalf of the OWNER, notify the surety of any potential default or liability.

SECTION 00700 - GENERAL CONDITIONS

5.2 INSURANCE

- A. The CONTRACTOR shall purchase and maintain the insurance required under this paragraph. Such insurance shall include the specific coverages set out herein and be written for not less than the limits of liability and coverages provided in the Supplementary General Conditions, or required by law, whichever are greater. All insurance shall be maintained continuously during the life of the Agreement up to the date of Final Completion and at all times thereafter when the CONTRACTOR may be correcting, removing, or replacing Defective WORK in accordance with Paragraph 13.6, but the CONTRACTOR's liabilities under this Agreement shall not be deemed limited in any way to the insurance coverage required.
- B. All insurance required by the Contract Documents to be purchased and maintained by the CONTRACTOR shall be obtained from insurance companies that are duly licensed or authorized in the State of Alaska to issue insurance policies for the limits and coverages so required. Such insurance companies shall have a current Best's Rating of at least an "A-Minus" general policy holder's rating and a Class IV financial size category and shall also meet such additional requirements and qualifications as may be provided in the Supplementary General Conditions.
- C. The CONTRACTOR shall furnish the OWNER with certificates showing the type, amount, class of operations covered, effective dates and dates of expiration of policies. All of the policies of insurance so required to be purchased and maintained (or the certificates or other evidence thereof) shall contain a provision or endorsement that the coverage afforded will not be cancelled, reduced in coverage, or renewal refused until at least 30 days' prior written notice has been given to the OWNER by certified mail. All such insurance required herein (except for Workers' Compensation and Employer's Liability) shall name the OWNER, its Consultants and subconsultants and their officers, directors, agents, and employees as "additional insureds" under the policies. The CONTRACTOR shall purchase and maintain the following insurance:
1. Workers' Compensation and Employer's Liability. This insurance shall protect the CONTRACTOR against all claims under applicable state workers' compensation laws. The CONTRACTOR shall also be protected against claims for injury, disease, or death of employees which, for any reason, may not fall within the provisions of a Workers' Compensation law. This policy shall include an "all states" endorsement. The CONTRACTOR shall require each Subcontractor similarly to provide Workers' Compensation Insurance for all of the latter's employees to be engaged in such WORK unless such employees are covered by the protection afforded by the CONTRACTOR's Workers' Compensation Insurance. In case any class of employees is not protected, under the Workers' Compensation Statute, the CONTRACTOR shall provide and shall cause each Subcontractor to provide adequate employer's liability insurance for the protection of such of its employees as are not otherwise protected.
 2. Commercial General Liability. This insurance shall be written in comprehensive form and shall protect the CONTRACTOR against all claims arising from injuries to persons other than its employees or damage to property of the OWNER or others arising out of any act or omission of the CONTRACTOR or its agents, employees, or Subcontractors.

SECTION 00700 - GENERAL CONDITIONS

The policy shall contain no exclusions for any operations within the scope of this contract.

3. Comprehensive Automobile Liability. This insurance shall be written in comprehensive form and shall protect the CONTRACTOR against all claims for injuries to members of the public and damage to property of others arising from the use of motor vehicles, and shall cover operation on or off the site of all motor vehicles licensed for highway use, whether they are owned, non-owned, or hired. Coverage for hired motor vehicles should include endorsement covering liability assumed under this Agreement.
4. Subcontractor's Commercial General Liability Insurance and Commercial Automobile Liability Insurance. The CONTRACTOR shall either require each of its Subcontractors to procure and to maintain Subcontractor's Commercial General Liability and Property Damage Insurance and Vehicle Liability Insurance of the type and in the amounts specified in the Supplementary General Conditions or insure the activities of its Subcontractors in the CONTRACTOR's own policy, in like amount.
5. Builder's Risk. This insurance shall be of the "all risks" type, shall be written in completed value form, and shall protect the CONTRACTOR, the OWNER, and the ENGINEER, against risks of damage to buildings, structures, and materials and equipment. The amount of such insurance shall be not less than the insurable value of the WORK at completion. Builder's risk insurance shall provide for losses to be payable to the CONTRACTOR and the OWNER, as their interests may appear. The policy shall contain a provision that in the event of payment for any loss under the coverage provided, the insurance company shall have no rights of recovery against the CONTRACTOR, the OWNER, and the ENGINEER. The Builder's Risk policy shall insure against all risks of direct physical loss or damage to property from any external cause including flood and earthquake. Allowable exclusions, if any, shall be as specified in the Supplementary General Conditions.

ARTICLE 6 CONTRACTOR'S RESPONSIBILITIES

6.1 SUPERVISION AND SUPERINTENDENCE

- A. The CONTRACTOR shall supervise, inspect, and direct the WORK competently and efficiently, devoting such attention thereto and applying such skills and expertise as may be necessary to perform the WORK in accordance with the Contract Documents. The CONTRACTOR shall be solely responsible for the means, methods, techniques, sequences, and procedures of construction and safety precautions and programs incidental thereto. The CONTRACTOR shall be responsible to see that the completed WORK complies accurately with the Contract Documents.
- B. The CONTRACTOR shall designate in writing and keep on the WORK site at all times during its progress a technically qualified, English-speaking superintendent, who is an employee of the CONTRACTOR and who shall not be replaced without written notice to the OWNER and the ENGINEER. The superintendent will be the CONTRACTOR's representative at the site and shall have authority to act on behalf of the CONTRACTOR. All communications given to the superintendent shall be as binding as if given to the CONTRACTOR. The CONTRACTOR shall issue all its communications to the OWNER through the ENGINEER and the ENGINEER only.

SECTION 00700 - GENERAL CONDITIONS

- C. The CONTRACTOR's superintendent shall be present at the site of the WORK at all times while WORK is in progress. Failure to observe this requirement shall be considered suspension of the WORK by the CONTRACTOR until such time as such superintendent is again present at the site.

6.2 LABOR, MATERIALS, AND EQUIPMENT

- A. The CONTRACTOR shall provide competent, suitably qualified personnel to survey and lay out the WORK and perform construction as required by the Contract Documents. The CONTRACTOR shall furnish, erect, maintain, and remove the construction plant and any temporary works as may be required. The CONTRACTOR shall at all times maintain good discipline and order at the site. Except in connection with the safety or protection of persons or the WORK or property at the site or adjacent thereto, and except as otherwise indicated in the Contract Documents, there shall be no restriction on the hours during which work may occur.
- B. Except as otherwise provided in this Paragraph, the CONTRACTOR shall receive no additional compensation for overtime work, i.e., work in excess of 8 hours in any one calendar day or 40 hours in any one calendar week, even though such overtime work may be required under emergency conditions and may be ordered by the ENGINEER in writing. Additional compensation will be paid the CONTRACTOR for overtime work only in the event extra work is ordered by the ENGINEER and the Change Order specifically authorizes the use of overtime work and then only to such extent as overtime wages are regularly being paid by the CONTRACTOR for overtime work of a similar nature in the same locality.
- C. All costs of inspection and testing performed during overtime work by the CONTRACTOR which is allowed solely for the convenience of the CONTRACTOR shall be borne by the CONTRACTOR. The OWNER shall have the authority to deduct the cost of all such inspection and testing from any partial payments otherwise due to the CONTRACTOR.
- D. Unless otherwise specified in the Contract Documents, the CONTRACTOR shall furnish and assume full responsibility for all materials, equipment, labor, transportation, construction equipment and machinery, tools, appliances, fuel, power, light, heat, telephone, water, sanitary facilities, and all other facilities and incidentals necessary for the furnishing, performance, testing, start-up, and completion of the WORK.
- E. All materials and equipment to be incorporated into the WORK shall be of good quality and new, except as otherwise provided in the Contract Documents. All warranties and guarantees specifically called for by the Specifications shall expressly run to the benefit of the OWNER. If required by the ENGINEER, the CONTRACTOR shall furnish satisfactory evidence (including reports of required tests) as to the kind and quality of materials and equipment. All materials and equipment shall be applied, installed, connected, erected, used, cleaned, and conditioned in accordance with the instructions of the applicable Supplier except as otherwise provided in the Contract Documents; but no provisions of any such instructions will be effective to assign to the ENGINEER, or any of the ENGINEER consultants, agents, or employees, any duty or authority to supervise or direct the furnishing or performance of the WORK or any duty or authority to undertake responsibility contrary to the provisions of Paragraphs 9.9C and 9.9D.

SECTION 00700 - GENERAL CONDITIONS

- F. The CONTRACTOR shall at all times employ sufficient labor and equipment for prosecuting the several classes of WORK to full completion in the manner and time set forth in and required by these specifications. All workers shall have sufficient skill and experience to perform properly the WORK assigned to them. Workers engaged in special WORK, or skilled WORK, shall have sufficient experience in such WORK and in the operation of the equipment required to perform all WORK, properly and satisfactorily.
- G. Any person employed by the CONTRACTOR or by any Subcontractor who, in the opinion of the ENGINEER, does not perform the WORK in a proper and skillful manner, or is intemperate or disorderly shall, at the written request of the ENGINEER, be removed forthwith by the CONTRACTOR or Subcontractor employing such person, and shall not be employed again in any portion of the WORK without the approval of the ENGINEER. Should the CONTRACTOR fail to remove such person or persons as required above, or fail to furnish suitable and sufficient personnel for the proper prosecution of the WORK, the ENGINEER may suspend the WORK by written notice until such orders are complied with.
- 6.3 ADJUSTING PROGRESS SCHEDULE. The CONTRACTOR shall submit monthly updates of the progress schedule to the ENGINEER for acceptance in accordance with the provisions in Section 01300 - CONTRACTOR Submittals in the General Requirements.
- 6.4 SUBSTITUTES OR "OR-EQUAL" ITEMS. The CONTRACTOR shall submit proposed substitutes or "or-equal" items in accordance with the provisions in Section 01300 - CONTRACTOR Submittals in the General Requirements.
- 6.5 CONCERNING SUBCONTRACTORS, SUPPLIERS, AND OTHERS.
- A. The CONTRACTOR shall be responsible to the OWNER and the ENGINEER for the acts and omissions of its Subcontractors and their employees to the same extent as CONTRACTOR is responsible for the acts and omissions of its own employees. Nothing contained in this Paragraph shall create any contractual relationship between any Subcontractor and the OWNER or the ENGINEER nor relieve the CONTRACTOR of any liability or obligation under the prime contract.
- B. The CONTRACTOR shall perform not less than 40% of the WORK with its own forces (i.e., without subcontracting). The 40% requirement shall be understood to mean that the CONTRACTOR shall perform, with its own organization, WORK amounting to at least 40% of the awarded contract amount. The 40% requirement will be calculated based upon the total of the subcontract amounts submitted for contract award, and any other information requested by the OWNER from the apparent low bidder.
- 6.6 PERMITS
- A. Unless otherwise provided in the Supplementary General Conditions, the CONTRACTOR shall obtain and pay for all construction permits and licenses from the agencies having jurisdiction, including the furnishing of insurance and bonds if required by such agencies. The enforcement of such requirements under this contract shall not be made the basis for claims for additional compensation. The OWNER shall assist the CONTRACTOR, when necessary, in obtaining such permits and licenses. The CONTRACTOR shall pay all governmental

SECTION 00700 - GENERAL CONDITIONS

charges and inspection fees necessary for the prosecution of the WORK, which are applicable at the time of opening of Bids. The CONTRACTOR shall pay all charges of utility owners for connections to the WORK.

- B. These Contract Documents may require that the WORK be performed within the conditions and/or requirements of local, state and/or federal permits. These permits may be bound within the Contract Documents, included within the Contract Documents by reference, or included as part of the WORK, as designated in this Section. The CONTRACTOR is responsible for completing the WORK required for compliance with all permit requirements; this WORK is incidental to other items in the Contract Documents. Any reference to the "permittee" in the permits shall mean the CONTRACTOR. If any permits were acquired by the OWNER, this action was done to expedite the start of construction. If the CONTRACTOR does not complete the WORK within the specified permit window, the CONTRACTOR shall be responsible for the permit extension, and for completing any additional requirements placed upon the permit.
 - C. These Contract Documents may require that the WORK be performed within the conditions and/or requirements of local, state and/or federal permits. These permits may be bound within the Contract Documents, included within the Contract Documents by reference, or included as part of the WORK, as designated in Section 00700, Article 6.6 - PERMITS. The CONTRACTOR is responsible for completing the WORK required for compliance with all permit requirements; this WORK is incidental to other items in the Contract Documents. Any reference to the "permittee" in the permits shall mean the CONTRACTOR. If any permits were acquired by the OWNER, this action was done to expedite the start of construction. If the CONTRACTOR does not complete the WORK within the specified permit window, the CONTRACTOR shall be responsible for the permit extension, and for completing any additional requirements placed upon the permit.
 - D. The OWNER shall apply for, and obtain, the necessary building permit for this project, however, the CONTRACTOR is responsible for scheduling and coordinating all necessary inspections. The City and Borough of Wrangell Inspection number is 874-3904. All other provisions of this Section remain in effect.
- 6.7 PATENT FEES AND ROYALTIES. The CONTRACTOR shall pay all license fees and royalties and assume all costs incident to the use in the performance of the WORK or the incorporation in the WORK of any invention, design, process, product, software or device which is the subject of patent rights or copyrights held by others. If a particular invention, design, process, product, or device is specified in the Contract Documents for use in the performance of the WORK and if to the actual knowledge of the OWNER or the ENGINEER its use is subject to patent rights or copyrights calling for the payment of any license fee or royalty to others, the existence of such rights shall be disclosed by the OWNER in the Contract Documents. The CONTRACTOR shall indemnify, defend and hold harmless the OWNER and the ENGINEER and anyone directly or indirectly employed by either of them from and against all claims, damages, losses, and expenses (including attorneys' fees and court costs) arising out of any infringement of patent rights or copyrights incident to the use in the performance of the WORK or resulting from the incorporation in the WORK of any invention, design, process, product, or device not specified in the Contract Documents, and shall defend all such claims in connection with any alleged infringement of such rights.

SECTION 00700 - GENERAL CONDITIONS

- 6.8 **LAWS AND REGULATIONS.** The CONTRACTOR shall observe and comply with all federal, state, and local laws, ordinances, codes, orders, and regulations which in any manner affect those engaged or employed on the WORK, the materials used in the WORK, or the conduct of the WORK. If any discrepancy or inconsistency should be discovered in this contract in relation to any such law, ordinance, code, order, or regulation, the CONTRACTOR shall report the same in writing to the ENGINEER. The CONTRACTOR shall indemnify, defend, and hold harmless the OWNER, the ENGINEER, and their officers, agents, and employees against all claims or liability arising from violation of any such law, ordinance, code, order, or regulation, whether by CONTRACTOR or by its employees, Subcontractors, or third parties. Any particular law or regulation specified or referred to elsewhere in the Contract Documents shall not in any way limit the obligation of the CONTRACTOR to comply with all other provisions of federal, state, and local laws and regulations. The OWNER may, per AS 36.30, audit the CONTRACTOR's or Subcontractor(s) records that are related to the cost or pricing data for this contract, all related Change Orders, and/or contract modifications.
- 6.9 **TAXES.** The CONTRACTOR shall pay all sales, consumer, use, and other similar taxes required to be paid by the CONTRACTOR in accordance with the Laws and Regulations of the place of the Project which are applicable during the performance of the WORK.
- 6.10 **USE OF PREMISES.** The CONTRACTOR shall confine construction equipment, the storage of materials and equipment, and the operations of workers to (1) the Project site, (2) the land and areas identified in and permitted by the Contract Documents, and (3) the other land and areas permitted by Laws and Regulations, rights-of-way, permits, leases and easements. The CONTRACTOR shall assume full responsibility for any damage to any such land or area, or to the owner or occupant thereof or of any land or areas contiguous thereto, resulting from the performance of the WORK. Should any claim be made against the OWNER or the ENGINEER by any such owner or occupant because of the performance of the WORK, the CONTRACTOR shall promptly attempt to settle with such other party by agreement or otherwise resolve the claim through litigation. The CONTRACTOR shall, to the fullest extent permitted by Laws and Regulations, indemnify, defend, and hold the OWNER and the ENGINEER harmless from and against all claims, damages, losses, and expenses (including, but not limited to, fees of engineers attorneys, and other professionals and court costs) arising directly, indirectly, or consequentially out of any action, legal or equitable, brought by any such owner or occupant against the OWNER, the ENGINEER, their Consultants, Sub-consultants, and the officers, directors, employees and agents of each and any of them to the extent caused by or based upon the CONTRACTOR's performance of the WORK.
- 6.11 **SAFETY AND PROTECTION**
- A. The CONTRACTOR shall be responsible for initiating, maintaining, and supervising all safety precautions and programs in connection with the WORK. The CONTRACTOR shall take all necessary precautions for the safety of, and shall provide the necessary protection to prevent damage, injury or loss to:
1. all employees on the WORK and other persons and organizations who may be affected thereby;
 2. all the WORK and materials and equipment to be incorporated therein, whether in storage on or off the site; and

SECTION 00700 - GENERAL CONDITIONS

3. other property at the site or adjacent thereto, including trees, shrubs, lawns, walks, pavements, roadways, structures, and utilities not designated for removal, relocation, or replacement in the course of construction.
- B. The CONTRACTOR shall comply with all applicable Laws and Regulations whether referred to herein or not) of any public body having jurisdiction for the safety of persons or property or to protect them from damage, injury, or loss and shall erect and maintain all necessary safeguards for such safety and protection. The CONTRACTOR shall notify owners of adjacent property and utilities when prosecution of the WORK may affect them, and shall cooperate with them in the protection, removal, relocation, and replacement of their property.
- C. The CONTRACTOR shall designate a qualified and experienced safety representative at the site whose duties and responsibilities shall be the prevention of accidents and the maintaining and supervising of safety precautions and program.
- D. Materials that contain hazardous substances or mixtures may be required on the WORK. A Material Safety Data Sheet shall be requested by the CONTRACTOR from the manufacturer of any hazardous product used.
- E. Material usage shall be accomplished with strict adherence to all safety requirements and all manufacturer's warnings and application instructions listed on the Material Safety Data Sheet and on the product container label.
- F. The CONTRACTOR shall be responsible for coordinating communications on any exchange of Material Safety Data Sheets or other hazardous material information that is required to be made available to, or exchanged between, or among, employers at the site in accordance with Laws or Regulations.
- G. The CONTRACTOR shall notify the ENGINEER if it considers a specified product or its intended usage to be unsafe. This notification must be given to the ENGINEER prior to the product being ordered, or if provided by some other party, prior to the product being incorporated in the WORK.

6.12 SHOP DRAWINGS AND SAMPLES

- A. After checking and verifying all field measurements and after complying with applicable procedures specified in the General Requirements, the CONTRACTOR shall submit to the ENGINEER for review, all Shop Drawings in accordance with Section 01300 - CONTRACTOR Submittals in the General Requirements.
- B. The CONTRACTOR shall also submit to the ENGINEER for review all samples in accordance with Section 01300 - CONTRACTOR Submittals in the General Requirements.
- C. Before submittal of each shop drawing or sample, the CONTRACTOR shall have determined and verified all quantities, dimensions, specified performance criteria, installation requirements, materials, catalog numbers, and similar data with respect thereto and reviewed or coordinated each Shop Drawing or sample with other Shop Drawings and samples and with the requirements of the WORK and the Contract Documents.

SECTION 00700 - GENERAL CONDITIONS

6.13 CONTINUING THE WORK. The CONTRACTOR shall carry on the WORK and adhere to the progress schedule during all disputes or disagreements with the OWNER. No work shall be delayed or postponed pending resolution of any disputes or disagreements, except as the CONTRACTOR and the OWNER may otherwise agree in writing.

6.14 INDEMNIFICATION

A. To the fullest extent permitted by Laws and Regulations, the CONTRACTOR shall indemnify, defend, and hold harmless the OWNER, the ENGINEER, their Consultants, Sub-consultants and the officers, directors, employees, and agents of each and any of them, against and from all claims and liability arising under, by reason of or incidentally to the contract or any performance of the WORK, but not from the sole negligence or willful misconduct of the OWNER, and the ENGINEER. Such indemnification by the CONTRACTOR shall include but not be limited to the following:

1. Liability or claims resulting directly or indirectly from the negligence or carelessness of the CONTRACTOR, its employees, or agents in the performance of the WORK, or in guarding or maintaining the same, or from any improper materials, implements, or appliances used in its construction, or by or on account of any act or omission of the CONTRACTOR, its employees, agents, or third parties;
2. Liability or claims arising directly or indirectly from bodily injury, occupational sickness or disease, or death of the CONTRACTOR's or Subcontractor's own employees engaged in the WORK resulting in actions brought by or on behalf of such employees against the OWNER, and the ENGINEER;
3. Liability or claims arising directly or indirectly from or based on the violation of any law, ordinance, regulation, order, or decree, whether by the CONTRACTOR, its employees, or agents;
4. Liability or claims arising directly or indirectly from the use or manufacture by the CONTRACTOR, its employees, or agents in the performance of this contract of any copyrighted or non-copyrighted composition, secret process, patented or non-patented invention, computer software, article, or appliance, unless otherwise specifically stipulated in this contract.
5. Liability or claims arising directly or indirectly from the breach of any warranties, whether express or implied, made to the OWNER or any other parties by the CONTRACTOR, its employees, or agents;
6. Liabilities or claims arising directly or indirectly from the willful or criminal misconduct of the CONTRACTOR, its employees, or agents; and,
7. Liabilities or claims arising directly or indirectly from any breach of the obligations assumed herein by the CONTRACTOR.

B. The CONTRACTOR shall reimburse the ENGINEER and the OWNER for all costs and expenses, (including but not limited to fees and charges of engineers, attorneys, and other professionals and court costs including all costs of appeals) incurred by said OWNER, and the ENGINEER in enforcing the provisions of this Paragraph 6.14.

C. The indemnification obligation under this Paragraph 6.14 shall not be limited in any way by any limitation of the amount or type of damages, compensation, or benefits payable by or for the CONTRACTOR or any such Subcontractor or other person or organization under workers' compensation acts, disability benefit acts, or other employee benefit acts.

SECTION 00700 - GENERAL CONDITIONS

- 6.15 **CONTRACTOR'S DAILY REPORTS.** The CONTRACTOR shall complete a daily report indicating total manpower for each construction trade, major equipment on site, each Subcontractor's manpower, weather conditions, etc., involved in the performance of the WORK. The daily report shall be completed on forms provided by the ENGINEER and shall be submitted to the ENGINEER at the conclusion of each work day. The report should comment on the daily progress, shall document any change of conditions encountered on-site, and status of the WORK within each major component of the WORK. These components will be decided by the ENGINEER.
- 6.16 **ASSIGNMENT OF CONTRACT.** The CONTRACTOR shall not assign, sublet, sell, transfer, or otherwise dispose of the contract or any portion thereof, or its right, title, or interest therein, or obligations thereunder, without the written consent of the OWNER except as imposed by law. If the CONTRACTOR violates this provision, the contract may be terminated at the option of the OWNER. In such event, the OWNER shall be relieved of all liability and obligations to the CONTRACTOR and to its assignee or transferee, growing out of such termination.
- 6.17 **CONTRACTOR'S RESPONSIBILITY FOR UTILITY PROPERTY AND SERVICES.** It is understood that any turn-on or turn-off, line locates and any other work or assistance necessary by the Wrangell Water Utilities Division, will be at the CONTRACTOR's expense unless otherwise stated in the bid documents. All cost must be agreed to prior to any related actions, and will be considered incidental to the project cost. Billing to the CONTRACTOR will be direct from the Wrangell Water Utilities Division.
- 6.18 **OPERATING WATER SYSTEM VALVES**
- A. The CONTRACTOR shall submit a written request, to the ENGINEER, for approval to operate any valve on any in-service section of the City and Borough of Wrangell water system. The request must be submitted at least 24-hours prior to operating any valves. The Wrangell Water Utilities Division reserves the right to approve or deny the request. The request shall specifically identify each valve to be operated, the time of operation, and the operation to be performed. The CONTRACTOR shall obtain the written approval of the ENGINEER for any scheduled operation before operating any valve.
- B. The CONTRACTOR shall be responsible for all damages, both direct and consequential, to the City or any other party, caused by unauthorized operation of any valve of the City and Borough of Wrangell water system.
- 6.19 **CONTRACTOR'S WORK SCHEDULE LIMITATIONS.** It is unlawful to operate any sand blaster, pile driver, power shovel, pneumatic hammer, derrick, power hoist, or similar heavy construction equipment before 7:00 am or after 10:00 pm, Monday through Friday, or before 9:00 am or after 8:00 pm, Saturday and Sunday, in excess of 60 decibels at the project limits, unless a permit shall first be obtained from the Wrangell Building Official. Such permit shall be issued by the Official only upon a determination that such operation during hours not otherwise permitted hereunder is necessary and will not result in unreasonable disturbance to surrounding residents and businesses.

ARTICLE 7 OTHER WORK

- 7.1 **RELATED WORK AT SITE**

SECTION 00700 - GENERAL CONDITIONS

- A. The OWNER may perform other work related to the Project at the site by the OWNER's own forces, have other work performed by utility owners, or let other direct contracts therefor which may contain General Conditions similar to these. If the fact that such other work is to be performed was not noted in the Contract Documents, written notice thereof will be given to the CONTRACTOR prior to starting any such other work.
 - B. The CONTRACTOR shall afford each other contractor who is a party to such a direct contract and each utility owner (or the OWNER, if the OWNER is performing the additional work with the OWNER's employees) proper and safe access to the site and a reasonable opportunity for the introduction and storage of materials and equipment and the execution of such work, and shall properly connect and coordinate the WORK with theirs. The CONTRACTOR shall do all cutting, fitting, and patching of the WORK that may be required to make its several parts come together properly and integrate with such other work. The CONTRACTOR shall not endanger any work of others by cutting, excavating, or otherwise altering their work and will only cut or alter their work with the written consent of the ENGINEER and the others whose work will be affected.
 - C. If the proper execution or results of any part of the CONTRACTOR's WORK depends upon the work of any such other contractor or utility owner (or OWNER), the CONTRACTOR shall inspect and report to the ENGINEER in writing any delays, defects, or deficiencies in such other work that render it unavailable or unsuitable for such proper execution and results. The CONTRACTOR's failure to report such delays, defects, or deficiencies will constitute an acceptance of the other work as fit and proper for integration with the CONTRACTOR's WORK except for latent or nonapparent defects and deficiencies in the other work.
- 7.2 COORDINATION. If the OWNER contracts with others for the performance of other work on the Project at the site, the person or organization who will have authority and responsibility for coordination of the activities among the various prime contractors will be identified in the Supplementary General Conditions, and the specific matters to be covered by such authority and responsibility will be itemized and the extent of such authority and responsibilities will be provided in the Supplementary General Conditions.

ARTICLE 8 OWNER'S RESPONSIBILITIES

8.1 COMMUNICATIONS

- A. The OWNER shall issue all its communications to the CONTRACTOR through the ENGINEER.
- B. The CONTRACTOR shall issue all its communications to the OWNER through the ENGINEER.

8.2 PAYMENTS. The OWNER shall make payments to the CONTRACTOR as provided in Paragraphs 14.5, 14.8, 14.9 and 14.10.

8.3 LANDS, EASEMENTS, AND SURVEYS. The OWNER's duties in respect of providing lands and easements and providing surveys to establish reference points are set forth in Paragraphs 4.1 and 4.5.

8.4 CHANGE ORDERS. The OWNER shall execute Change Orders as indicated in Paragraph 10.1F.

SECTION 00700 - GENERAL CONDITIONS

- 8.5 INSPECTIONS AND TESTS. The OWNER's responsibility in respect of inspections, tests, and approvals is set forth in Paragraph 13.3.
- 8.6 SUSPENSION OF WORK. In connection with the OWNER's right to stop WORK or suspend WORK, see Paragraphs 13.4 and 15.1.
- 8.7 TERMINATION OF AGREEMENT. Paragraphs 15.2 and 15.3 deal with the OWNER's right to terminate services of the CONTRACTOR.

ARTICLE 9 ENGINEER'S STATUS DURING CONSTRUCTION

- 9.1 OWNER'S REPRESENTATIVE. The ENGINEER will be the OWNER's representative during the construction period. The duties and responsibilities and the limitations of authority of the ENGINEER as the OWNER's representative during construction are set forth in the Contract Documents.
- 9.2 VISITS TO SITE. The ENGINEER will make visits to the site during construction to observe the progress and quality of the WORK and to determine, in general, if the WORK is proceeding in accordance with the Contract Documents. Exhaustive or continuous on-site inspections to check the quality or quantity of the WORK will not be required of the ENGINEER. The ENGINEER will not, during such visits, or as a result of such observations of the CONTRACTOR's WORK in progress, supervise, direct, or have control over the CONTRACTOR's WORK.
- 9.3 PROJECT REPRESENTATION. The ENGINEER may furnish an Inspector to assist in observing the performance of the WORK. The duties, responsibilities, and limitations of authority are as follows:

A. Duties, Responsibilities and Limitations of Authority of Inspector

General. The Inspector, who is the ENGINEER's Agent, will act as directed by and under the supervision of the ENGINEER and will confer with the ENGINEER regarding its actions. The Inspector's dealings in matters pertaining to the on-site WORK shall, in general, be only with the ENGINEER and the CONTRACTOR, and dealings with Subcontractors shall only be through or with the full knowledge of the CONTRACTOR. Written communication with the OWNER will be only through or as directed by the ENGINEER.

Duties and Responsibilities. The Inspector will:

1. Review the progress schedule, list of Shop Drawing submittals and schedule of values prepared by the CONTRACTOR and consult with the ENGINEER concerning their acceptability.
2. Attend pre-construction conferences. Arrange a schedule of progress meetings and other job conferences as required in consultation with the ENGINEER and notify those expected to attend in advance. Attend meetings and maintain and circulate copies of minutes thereof.
3. Serve as the ENGINEER's liaison with the CONTRACTOR, working principally through the CONTRACTOR's superintendent and assist said superintendent in understanding the intent of the Contract Documents. Assist the ENGINEER in serving as the OWNER's liaison with the CONTRACTOR when the CONTRACTOR's operations affect the OWNER's on-site operations.

SECTION 00700 - GENERAL CONDITIONS

4. As requested by the ENGINEER, assist in obtaining from the OWNER additional details or information, when required at the site for proper execution of the WORK.
5. Receive and record date of receipt of Shop Drawings and samples, receive samples which are furnished at the site by the CONTRACTOR and notify the ENGINEER of their availability for examination.
6. Conduct on-site observations of the WORK in progress to assist the ENGINEER in determining if the WORK is proceeding in accordance with the Contract Documents.
7. Report to the ENGINEER whenever the Inspector believes that any WORK is unsatisfactory, faulty, or defective or does not conform to the Contract Documents, or does not meet the requirements of any inspection, tests or approval required to be made or has been damaged prior to final payment; and advise the ENGINEER when the Inspector believes WORK should be corrected or rejected or should be uncovered for observation, or requires special testing, inspection, or approval.
8. Verify that the tests, equipment, and systems startups and operating and maintenance instruction are conducted as required by the Contract Documents and in presence of the required personnel, and that the CONTRACTOR maintains adequate records thereof; observe, record and report to the ENGINEER appropriate details relative to the test procedures and start-ups.
9. Accompany visiting inspectors representing public or other agencies having jurisdiction over the WORK, record the outcome of these inspections, and report to the ENGINEER.
10. Transmit to the CONTRACTOR the ENGINEER's clarifications and interpretations of the Contract Documents.
11. Consider and evaluate the CONTRACTOR's suggestions for modifications in the Contract Documents and report them with recommendations to the ENGINEER.
12. Maintain at the job site orderly files for correspondence, reports of job conferences, Shop Drawings and sample submittals, reproductions of original Contract Documents including all addenda, Change Orders, field orders, additional Drawings issued subsequent to the execution of the contract, the ENGINEER's clarifications and interpretations of the Contract Documents, progress reports, and other related documents.
13. Keep a diary or log book, recording hours on the job site, weather conditions, data relative to questions of extras or deductions, list all project visitors, daily activities, decisions, observations in general, and specific observations in more detail as in the case of performing and observing test procedures. Send copies to the ENGINEER.
14. Record names, addresses, and telephone numbers of the CONTRACTOR, Subcontractors, and major suppliers of materials and equipment.
15. Furnish the ENGINEER with periodic reports as required of progress of the WORK and the CONTRACTOR's compliance with the accepted progress schedule and schedule of CONTRACTOR submittals.
16. Consult with the ENGINEER in advance of scheduled major tests, inspections, or start of important phases of the WORK.
17. Report immediately to the ENGINEER upon the occurrence of any accident.
18. Review applications for payment with the CONTRACTOR for compliance with the established procedure for their submittal and forward them with recommendations to the ENGINEER, noting particularly their relation to the schedule of values, WORK completed, and materials and equipment delivered at the site but not incorporated in the WORK.

SECTION 00700 - GENERAL CONDITIONS

19. During the course of the WORK, verify that certificates, maintenance and operation manuals, and other data required to be assembled and furnished by the CONTRACTOR are applicable to the items actually installed; and deliver this material to the ENGINEER for its review and forwarding to the OWNER prior to final acceptance of the WORK.
20. Before the ENGINEER prepares a Certificate of Substantial Completion/Notice of completion, as applicable, review the CONTRACTOR's punch list items requiring completion or correction and add any items that CONTRACTOR has omitted.
21. Conduct final inspection in the company of the ENGINEER, the OWNER, and the CONTRACTOR, and prepare a final punch list of items to be completed or corrected.
22. Verify that all items on the punch list have been completed or corrected and make recommendations to the ENGINEER concerning acceptance.

Limitations of Authority. Except upon written instruction of the ENGINEER, the Inspector:

1. Shall not authorize any deviation from the Contract Documents or approve any substitute material or equipment.
2. Shall not exceed limitations on the ENGINEER's authority as set forth in the Contract Documents.
3. Shall not undertake any of the responsibilities of the CONTRACTOR, Subcontractors or CONTRACTOR's superintendent, or expedite the WORK.
4. Shall not advise on or issue directions relative to any aspect of the means, methods, techniques, sequences, or procedures of construction unless such is specifically called for in the Contract Documents.
5. Shall not advise on or issue directions as to safety precautions and programs in connection with the WORK.

9.4 CLARIFICATIONS AND INTERPRETATIONS. The ENGINEER will issue with reasonable promptness such written clarifications or interpretations of the requirements of the Contract Documents (in the form of Drawings or otherwise) as the ENGINEER may determine necessary, which shall be consistent with, or reasonably inferred from, the overall intent of the Contract Documents.

9.5 AUTHORIZED VARIATIONS IN WORK. The ENGINEER may authorize variations in the WORK from the requirements of the Contract Documents. These may be accomplished by a Field Order and will require the CONTRACTOR to perform the WORK involved in a manner that minimizes the impact to the WORK and the contract completion date. If the CONTRACTOR believes that a Field Order justifies an increase in the Contract Price or an extension of the Contract Time, the CONTRACTOR may make a claim therefor as provided in Article 11 or 12.

9.6 REJECTING DEFECTIVE WORK. The ENGINEER will have authority to reject WORK which the ENGINEER believes to be defective and will also have authority to require special inspection or testing of the WORK as provided in Paragraph 13.3G, whether or not the WORK is fabricated, installed, or completed.

9.7 CONTRACTOR SUBMITTALS, CHANGE ORDERS, AND PAYMENTS

- A. In accordance with the procedures set forth in the General Requirements, the ENGINEER will review all CONTRACTOR submittals, including Shop Drawings, samples, substitutes, or

SECTION 00700 - GENERAL CONDITIONS

"or equal" items, etc., in order to determine if the items covered by the submittals will, after installation or incorporation in the WORK, conform to the requirements of the Contract Documents and be compatible with the design concept of the completed project as a functioning whole as indicated by the Contract Documents. The ENGINEER's review will not extend to means, methods, techniques, sequences or procedures of construction or to safety precautions or programs incident thereto.

- B. In connection with the ENGINEER's responsibilities as to Change Orders, see Articles 10, 11, and 12.
- C. In connection with the ENGINEER's responsibilities in respect of Applications for Payment, see Article 14.

9.8 DECISIONS ON DISPUTES

- A. The ENGINEER will be the initial interpreter of the requirements of the Contract Documents and judge of the acceptability of the WORK thereunder. Claims, disputes, and other matters relating to the acceptability of the WORK; the interpretation of the requirements of the Contract Documents pertaining to the performance of the WORK; and those claims under Articles 11 and 12 in respect to changes in the Contract Price or Contract Time will be referred initially to the ENGINEER in writing with a request for formal decision in accordance with this paragraph, which the ENGINEER will render in writing within 30 days of receipt of the request. Written notice of each such claim, dispute, and other matter will be delivered by the CONTRACTOR to the ENGINEER promptly (but in no event later than 30 days) after the occurrence of the event giving rise thereto. Written supporting data will be submitted to the ENGINEER within 60 days after such occurrence unless the ENGINEER allows an additional period of time to ascertain more accurate data in support of the claim.
- B. The rendering of a decision by the ENGINEER with respect to any such claim, dispute, or other matter (except any which have been waived by the making or acceptance of final payment as provided in Paragraph 14.12) will be a condition precedent to any exercise by the OWNER or the CONTRACTOR) of such rights or remedies as either may otherwise have under the Contract Documents or by Law or Regulations in respect of any such claim, dispute, or other matter.

9.9 LIMITATION ON ENGINEER'S RESPONSIBILITIES

- A. Neither the ENGINEER's authority to act under this Article or other provisions of the Contract Documents nor any decision made by the ENGINEER in good faith either to exercise or not exercise such authority shall give rise to any duty or responsibility of the ENGINEER to the CONTRACTOR, any Subcontractor, any Supplier, any surety for any of them, or any other person or organization performing any of the WORK.
- B. Whenever in the Contract Documents the terms "as ordered," "as directed," "as required," "as allowed," "as reviewed," "as approved," or terms of like effect or import are used, or the adjectives "reasonable," "suitable," "acceptable," "proper," or "satisfactory" or adjectives of like effect or import are used to describe a requirement, direction, review, or judgment of the ENGINEER as to the WORK, it is intended that such requirement, direction, review, or judgment will be solely to evaluate the WORK for compliance with the requirements of the

SECTION 00700 - GENERAL CONDITIONS

Contract Documents, and conformance with the design concept of the completed Project as a functioning whole as indicated by the Contract Documents, unless there is a specific statement indicating otherwise. The use of any such term or adjective shall not be effective to assign to the ENGINEER any duty or authority to supervise or direct the performance of the WORK or any duty or authority to undertake responsibility contrary to the provisions of Paragraph 9.9C or 9.9D.

- C. The ENGINEER will not supervise, direct, control, or have authority over or be responsible for the CONTRACTOR's means, methods, techniques, sequences, or procedures of construction, or the safety precautions and programs incident thereto, or for any failure of the CONTRACTOR to comply with Laws and Regulations, applicable to the performance of the WORK. The ENGINEER will not be responsible for the CONTRACTOR's failure to perform the WORK in accordance with the Contract Documents.
- D. The ENGINEER will not be responsible for the acts or omissions of the CONTRACTOR nor of any Subcontractor, supplier, or any other person or organization performing any of the WORK.

ARTICLE 10 CHANGES IN THE WORK

10.1 GENERAL

- A. Without invalidating the Agreement and without notice to any surety, the OWNER may at any time or from time to time, order additions, deletions, or revisions in the WORK; these will be authorized by a written Field Order and/or a Change Order issued by the ENGINEER.
- B. If the CONTRACTOR believes that it is entitled to an increase or decrease in the Contract Price, or an extension or shortening in the Contract Time as the result of a Field Order, a claim may be made as provided in Articles 11 and 12.
- C. If the OWNER and CONTRACTOR agree on the value of any work, or the amount of Contract Time that should be allowed as a result of a Field Order, upon receiving written notice from the ENGINEER, the CONTRACTOR shall proceed so as to minimize the impact on and delays to the work pending the issuance of a Change Order.
- D. If the OWNER and the CONTRACTOR are unable to agree as to the extent, if any, of an increase or decrease in the Contract Price or an extension or shortening of the Contract Time that should be allowed as a result of a Field Order, the ENGINEER can direct the CONTRACTOR to proceed on the basis of Time and Materials so as to minimize the impact on and delays to WORK, and a claim may be made therefor as provided in Articles 11 and 12.
- E. The CONTRACTOR shall not be entitled to an increase in the Contract Price nor an extension of the Contract Time with respect to any work performed that is not required by the Contract Documents as amended, modified, supplemented by Change Order, except in the case of an emergency and except in the case of uncovering work as provided in Paragraph 13.3G.
- F. The OWNER and the CONTRACTOR shall execute appropriate Change Orders covering:

SECTION 00700 - GENERAL CONDITIONS

1. changes in the WORK which are ordered by the OWNER pursuant to Paragraph 10.1A;
 2. changes required because of acceptance of Defective WORK under Paragraph 13.7;
 3. changes in the Contract Price or Contract Time which are agreed to by the parties; or
 4. changes in the Contract Price or Contract Times which embody the substance of any written decision rendered by the ENGINEER pursuant to Paragraph 9.8.
- G. If notice of any change is required by the provisions of any Bond to be given to a surety, the giving of any such notice will be the CONTRACTOR's responsibility, and the amount of each applicable Bond shall be adjusted accordingly.

10.2 ALLOWABLE QUANTITY VARIATIONS

- A. In the event of an increase or decrease in Bid item quantity of a unit price contract, the total amount of WORK actually done or materials or equipment furnished shall be paid for according to the unit price established for such WORK under the Contract Documents, wherever such unit price has been established; provided, that an adjustment in the Contract Price may be made for changes which result in an increase or decrease in excess of 25% of the estimated quantity of any major item of the WORK. Major Item is defined as any bid item amount that is ten percent (10%) or more of the total contract amount.
- B. In the event a part of the WORK is to be entirely eliminated and no lump sum or unit price is named in the Contract Documents to cover such eliminated work, the price of the eliminated work shall be agreed upon in writing by the OWNER and the CONTRACTOR. If the OWNER and the CONTRACTOR fail to agree upon the price of the eliminated work, said price shall be determined in accordance with the provisions of Article 11.

ARTICLE 11 CHANGE OF CONTRACT PRICE

11.1 GENERAL

- A. The Contract Price constitutes the total compensation payable to the CONTRACTOR for performing the WORK. All duties, responsibilities, and obligations assigned to or undertaken by the CONTRACTOR to complete the WORK shall be at its expense without change in the Contract Price.
- B. The Contract Price may only be changed by a Change Order. Any claim for an increase in the Contract Price shall be based on written notice delivered by the CONTRACTOR to the ENGINEER promptly (but in no event later than 7 days) after the start of the occurrence or the event giving rise to the claim and stating the general nature of the claim. Notice of the amount of the claim with supporting data shall be delivered within 14 days after such occurrence (unless the ENGINEER allows an additional period of time to ascertain more accurate data in support of the claim) and shall be accompanied by the CONTRACTOR's written statement that the amount claimed covers all known amounts (direct, indirect, and consequential) to which the CONTRACTOR is entitled as a result of said occurrence or event. All claims for adjustment in the Contract Price shall be determined by the ENGINEER in accordance with Paragraph 9.8A if the OWNER and the CONTRACTOR cannot otherwise agree on the amount involved. No claim for an adjustment in the Contract Price will be valid if not submitted in accordance with this Paragraph 11.1B.

SECTION 00700 - GENERAL CONDITIONS

- C. The value of any work covered by a Change Order or of any claim for an increase or decrease in the Contract Price shall be determined in one of the following ways:
1. Where the work involved is covered by unit prices contained in the Contract Documents, by application of unit prices to the quantities of the items involved.
 2. By mutual acceptance of a lump sum, which may include an allowance for overhead and profit not necessarily in accordance with Paragraph 11.4.
 3. On the basis of the cost of work (determined as provided in Paragraphs 11.3) plus a CONTRACTOR's fee for overhead and profit (determined as provided in Paragraph 11.4).
- 11.2 COSTS RELATING TO WEATHER. The CONTRACTOR shall have no claims against the OWNER for damages for any injury to WORK, materials, or equipment, resulting from the action of the elements. If, however, in the opinion of the ENGINEER, the CONTRACTOR has made all reasonable efforts to protect the materials, equipment and work, the CONTRACTOR may be granted a reasonable extension of Contract Time to make proper repairs, renewals, and replacements of the work, materials, or equipment.
- 11.3 COST OF WORK (BASED ON TIME AND MATERIALS)
- A. General. The term "cost of work" means the sum of all costs necessarily incurred and paid by the CONTRACTOR for labor, materials, and equipment in the proper performance of extra work. Except as otherwise may be agreed to in writing by the OWNER, such costs shall be in amounts no higher than those prevailing in the locality of the Project; shall include only the following items, and shall not include any of the costs itemized in Paragraph 11.5 EXCLUDED COSTS.
- B. Labor. The costs of labor will be the actual cost for wages prevailing for each craft or type of workers performing the extra work at the time the extra work is done, plus employer payments of payroll taxes, worker's compensation insurance, liability insurance, health and welfare, pension, vacation, apprenticeship funds, and other direct costs resulting from Federal, State or local laws, as well as assessments or benefits required by lawful collective bargaining agreements. Labor costs for equipment operators and helpers shall be paid only when such costs are not included in the invoice for equipment rental. The labor costs for forepersons shall be proportioned to all of their assigned work and only that applicable to extra work shall be paid. Non-direct labor costs including superintendence shall be considered part of the mark-up set out in paragraph 11.4.
- C. Materials. The cost of materials reported shall be at invoice or lowest current price at which materials are locally available and delivered to the job in the quantities involved, plus the cost of freight, delivery and storage, subject to the following:
1. Trade discounts available to the purchaser shall be credited to the OWNER notwithstanding the fact that such discounts may not have been taken by the CONTRACTOR.
 2. For materials secured by other than a direct purchase and direct billing to the purchaser, the cost shall be deemed to be the price paid to the actual supplier as determined by the

SECTION 00700 - GENERAL CONDITIONS

ENGINEER. Mark-up except for actual costs incurred in the handling of such materials will not be allowed.

3. Payment for materials from sources owned wholly or in part by the purchaser shall not exceed the price paid by the purchaser for similar materials from said sources on extra work items or the current wholesale price for such materials delivered to the work site, whichever price is lower.
4. If in the opinion of the ENGINEER the cost of material is excessive, or the CONTRACTOR does not furnish satisfactory evidence of the cost of such material, then the cost shall be deemed to be the lowest current wholesale price for the quantity concerned delivered to the work site less trade discount. The OWNER reserves the right to furnish materials for the extra work and no claim shall be allowed by the CONTRACTOR for costs and profit on such materials.

D. Equipment. The CONTRACTOR will be paid for the use of equipment at the rental rate listed for such equipment specified in the Supplementary General Conditions. Such rental rate will be used to compute payments for equipment whether the equipment is under the CONTRACTOR's control through direct ownership, leasing, renting, or another method of acquisition. The rental rate to be applied for use of each item of equipment shall be the rate resulting in the least total cost to the OWNER for the total period of use. If it is deemed necessary by the CONTRACTOR to use equipment not listed in the publication specified in the Supplementary General Conditions, an equitable rental rate for the equipment will be established by the ENGINEER. The CONTRACTOR may furnish cost data which might assist the ENGINEER in the establishment of the rental rate.

1. All equipment shall, in the opinion of the ENGINEER, be in good working condition and suitable for the purpose for which the equipment is to be used.
2. Before construction equipment is used on the extra work, the CONTRACTOR shall plainly stencil or stamp an identifying number thereon at a conspicuous location, and shall furnish to the ENGINEER, in duplicate, a description of the equipment and its identifying number.
3. Unless otherwise specified, manufacturer's ratings and manufacturer approved modifications shall be used to classify equipment for the determination of applicable rental rates. Equipment which has no direct power unit shall be powered by a unit of at least the minimum rating recommended by the manufacturer.
4. Individual pieces of equipment or tools having a replacement value of \$200 or less, whether or not consumed by use, shall be considered to be small tools and no payment will be made therefor.
5. Rental time will not be allowed while equipment is inoperative due to breakdowns.
6. Equipment Rental Rates. Unless otherwise agreed in writing, the CONTRACTOR will be paid for the use of equipment at the rental rate listed for such equipment specified in the current edition of the following reference publication: "Rental Rate Blue Book" as published by Dataquest (a company of the Dunn and Bradstreet Corporation), 1290 Ridder Park Drive, San Jose, CA 95131, telephone number (800) 227-8444.

E. Equipment on the Work Site. The rental time to be paid for equipment on the work site shall be the time the equipment is in productive operation on the extra work being performed and, in addition, shall include the time required to move the equipment to the location of the extra work and return it to the original location or to another location requiring no more time than that required to return it to its original location; except, that moving time will not be paid if

SECTION 00700 - GENERAL CONDITIONS

the equipment is used on other than the extra work, even though located at the site of the extra work. Loading and transporting costs will be allowed, in lieu of moving time, when the equipment is moved by means other than its own power, except that no payment will be made for loading and transporting costs when the equipment is used at the site of the extra work on other than the extra work. The following shall be used in computing the rental time of equipment on the work site.

1. When hourly rates are listed, any part of an hour less than 30 minutes of operation shall be considered to be 1/2-hour of operation, and any part of an hour in excess of 30 minutes will be considered one hour of operation.
 2. When daily rates are listed, any part of a day less than 4 hours operation shall be considered to be 1/2-day of operation. When owner-operated equipment is used to perform extra work to be paid for on a time and materials basis, the CONTRACTOR will be paid for the equipment and operator, as set forth in Paragraphs (3), (4), and (5), following.
 3. Payment for the equipment will be made in accordance with the provisions in Paragraph 11.3D, herein.
 4. Payment for the cost of labor and subsistence or travel allowance will be made at the rates paid by the CONTRACTOR to other workers operating similar equipment already on the work site, or in the absence of such labor, established by collective bargaining agreements for the type of worker and location of the extra work, whether or not the operator is actually covered by such an agreement. A labor surcharge will be added to the cost of labor described herein in accordance with the provisions of Paragraph 11.3B, herein, which surcharge shall constitute full compensation for payments imposed by state and federal laws and all other payments made to or on behalf of workers other than actual wages.
 5. To the direct cost of equipment rental and labor, computed as provided herein, will be added the allowances for equipment rental and labor as provided in Paragraph 11.4, herein.
- F. Specialty Work. Specialty work is defined as that work characterized by extraordinary complexity, sophistication, or innovation or a combination of the foregoing attributes which are unique to the construction industry. The following shall apply in making estimates for payment for specialty work:
1. Any bid item of WORK to be classified as Specialty Work shall be listed as such in the Supplementary General Conditions. Specialty work shall be performed by an entity especially skilled in the work to be performed. After validation of invoices and determination of market values by the ENGINEER, invoices for specialty work based upon the current fair market value thereof may be accepted without complete itemization of labor, material, and equipment rental costs.
 2. When the CONTRACTOR is required to perform work necessitating special fabrication or machining process in a fabrication or a machine shop facility away from the job site, the charges for that portion of the work performed at the off-site facility may, by agreement, be accepted as specialty work and accordingly, the invoices for the work may be accepted without detailed itemization.
 3. All invoices for specialty work will be adjusted by deducting all trade discounts offered or available, whether the discounts were taken or not. In lieu of the allowances for

SECTION 00700 - GENERAL CONDITIONS

overhead and profit specified in Paragraph 11.4, herein, an allowance of 5 percent will be added to invoices for specialty work.

- G. Sureties. All work performed hereunder shall be subject to all of the provisions of the Contract Documents and the CONTRACTOR's sureties shall be bound with reference thereto as under the original Agreement. Copies of all amendments to surety bonds or supplemental surety bonds shall be submitted to the OWNER for review prior to the performance of any work hereunder.

11.4 CONTRACTOR'S FEE

- A. Extra work ordered on the basis of time and materials will be paid for at the actual necessary cost as determined by the ENGINEER, plus allowances for overhead and profit. The allowance for overhead and profit shall include full compensation for superintendence, bond and insurance premiums, taxes, field office expense, extended overhead, home office overhead, and all other items of expense or cost not included in the cost of labor, materials, or equipment provided for under Paragraph 11.3. The allowance for overhead and profit will be made in accordance with the following schedule:

Actual Overhead and Profit Allowance

Labor.....	15 percent
Materials	10 percent
Equipment.....	10 percent

To the sum of the costs and mark-ups provided for in this Article, one percent shall be added as compensation for bonding.

- B. It is understood that labor, materials, and equipment may be furnished by the CONTRACTOR or by the Subcontractor on behalf of the CONTRACTOR. When all or any part of the extra work is performed by a Subcontractor, the allowance specified herein shall be applied to the labor, materials, and equipment costs of the Subcontractor, to which the CONTRACTOR may add 5 percent of the Subcontractor's total cost for the extra work. Regardless of the number of hierarchical tiers of Subcontractors, the 5 percent increase above the Subcontractor's total cost which includes the allowances for overhead and profit specified herein may be applied one time only.

11.5 EXCLUDED COSTS. The term Cost of the Work shall not include any of the following:

- A. Payroll costs and other compensation of CONTRACTOR's officers, executives, principals (of partnership and sole proprietorships), general managers, engineers, estimators, attorneys' auditors, accountants, purchasing and contracting agents, expenditures, timekeepers, clerks and other personnel employed by CONTRACTOR whether at the site or in CONTRACTOR's principal or a branch office for general administration of the work, or not specifically covered by paragraph 11.3, all of which are to be considered administrative costs covered by the CONTRACTOR's fee.
- B. Expenses of CONTRACTOR's principal and branch offices other than CONTRACTOR's office at the site.

SECTION 00700 - GENERAL CONDITIONS

- C. Any part of CONTRACTOR's capital expenses, including interest on CONTRACTOR's capital employed for the Work and charges against CONTRACTOR for delinquent payments.
- D. Cost of premiums for all bonds and for all insurance whether or not CONTRACTOR is required by the Contract Documents to purchase and maintain the same (except for the cost of premiums covered by paragraph 11.4 above).
- E. Costs due to the negligence of CONTRACTOR , any Subcontractor, or anyone directly or indirectly employed by any of them or for whose acts any of them may be liable, including but not limited to, the correction of Defective WORK, disposal of materials or equipment wrongly supplied and making good any damage to property.
- F. Other overhead or general expense costs of any kind and the cost of any item not specifically and expressly included in paragraph 11.4.

ARTICLE 12 CHANGE OF CONTRACT TIME

12.1 GENERAL

- A. The Contract Time may only be changed by a Change Order. Any claim for an extension of the Contract Time (or Milestones) shall be based on written notice delivered by the CONTRACTOR to the ENGINEER promptly (but in no event later than 30 days) after the occurrence of the event giving rise to the claim and stating the general nature of the claim. Notice of the extent of the claim with supporting data shall be delivered within 60 days after such occurrence (unless the ENGINEER allows an additional period of time to ascertain more accurate data in support of the claim) and shall be accompanied by the CONTRACTOR'S written statement that the adjustment claimed is the entire adjustment to which the CONTRACTOR has reason to believe it is entitled as a result of the occurrence of said event. All claims for adjustment in the Contract Time shall be determined by the ENGINEER in accordance with Paragraph 9.8 if the OWNER and the CONTRACTOR cannot otherwise agree. No claim for an adjustment in the Contract Time will be valid if not submitted in accordance with the requirements of this Paragraph 12.1A. An increase in Contract Time does not mean that the Contractor is due an increase in Contract Price. Only Compensable time extensions will result in an increase in Contract Price.
- B. All time limits stated in the Contract Documents are of the essence of the Agreement.
- C. Where CONTRACTOR is prevented from completing any part of the Work within the Contract Times (or Milestones) due to delay beyond the control of CONTRACTOR, the Contract Times (or Milestones) will be extended in an amount equal to the time lost on the critical path of the project due to such delay if a claim is made therefor as provided in paragraph 12.1. Delays beyond the control of CONTRACTOR shall include, but not be limited to, acts or neglect by OWNER, acts or neglect of utility owners or other contractors performing other work as contemplated by Article 7, fires, floods, epidemics, unprecedented weather conditions or acts of God. Delays attributable to and within the control of a Subcontractor or Supplier shall be deemed to be delays within the control of CONTRACTOR.

SECTION 00700 - GENERAL CONDITIONS

D. Where CONTRACTOR is prevented from completing any part of the WORK within the Contract Times (or Milestones) due to delay beyond the control of both OWNER and CONTRACTOR, an extension of the Contract Times (or Milestones) in an amount equal to the time lost on the critical path of the project due to such delay shall be CONTRACTOR's sole and exclusive remedy for such delay. In no event shall the OWNER be liable to CONTRACTOR, any Subcontractor, any Supplier, or any other person or organization, or to any surety for or employee or agent of any of them, for damages arising out of or resulting from (i) delays caused by or within the control of CONTRACTOR, or (ii) delays beyond the control of both parties including but not limited to fires, floods, epidemics abnormal weather conditions, acts of God or acts or neglect by utility owners or other contractors performing other work as contemplated by Article 7.

12.2 EXTENSIONS OF TIME FOR DELAY DUE TO WEATHER. Contract Time may be extended by the ENGINEER because of delays in completion of the WORK due to unusually severe weather, provided that the CONTRACTOR shall, within 10 days of the beginning of any such delay, notify the ENGINEER in writing of the cause of delay and request an extension of Contract Time. The ENGINEER will ascertain the facts and the extent of the delay and extend the time for completing the work when, in the ENGINEER's judgment, the findings of fact justify such an extension. Unprecedented, abnormal, or unusually severe weather will be defined as an event, or events, with a greater than 50-year recurrence interval, as determined by the National Weather Service, or equivalent State or Federal agency

ARTICLE 13 WARRANTY AND GUARANTEE; TESTS AND INSPECTIONS; CORRECTION, REMOVAL, OR ACCEPTANCE OF DEFECTIVE WORK

13.1 WARRANTY AND GUARANTEE. The CONTRACTOR warrants and guarantees to the OWNER and the ENGINEER that all work will be in accordance with the Contract Documents and will not be defective. Prompt notice of defects known to the OWNER or ENGINEER shall be given to the CONTRACTOR. All defective work, whether or not in place, may be rejected, corrected, or accepted as provided in this Article 13.

13.2 ACCESS TO WORK. OWNER, ENGINEER, their Consultants, sub-consultants, other representatives and personnel of OWNER, independent testing laboratories and governmental agencies with jurisdictional interests will have access to the Work at reasonable times for their observation, inspecting and testing. CONTRACTOR shall provide them proper and safe conditions for such access and advise them of CONTRACTOR's site safety procedures and programs so that they may comply therewith as applicable.

13.3 TESTS AND INSPECTIONS

A. The CONTRACTOR shall give the ENGINEER timely notice of readiness of the WORK for all required inspections, tests, or approvals, and shall cooperate with inspection and testing personnel to facilitate required inspections or tests.

B. If Laws or Regulations of any public body having jurisdiction other than the OWNER require any WORK to specifically be inspected, tested, or approved, the CONTRACTOR shall pay all costs in connection therewith. The CONTRACTOR shall also be responsible for and shall pay all costs in connection with any inspection or testing required in connection with the OWNER's or the ENGINEER's acceptance of a Supplier of materials or equipment proposed

SECTION 00700 - GENERAL CONDITIONS

as a substitution or (or-equal) to be incorporated in the WORK, or of materials or equipment submitted for review prior to the CONTRACTOR's purchase thereof for incorporation in the WORK. The cost of all inspections, tests, and approvals in addition to the above which are required by the Contract Documents shall be paid by the OWNER (unless otherwise specified).

- C. The ENGINEER will make, or have made, such inspections and tests as the ENGINEER deems necessary to see that the WORK is being accomplished in accordance with the requirements of the Contract Documents. Unless otherwise specified in the Supplementary General Conditions, the cost of such inspection and testing will be borne by the OWNER. In the event such inspections or tests reveal non-compliance with the requirements of the Contract Documents, the CONTRACTOR shall bear the cost of corrective measures deemed necessary by the ENGINEER, as well as the cost of subsequent reinspection and retesting. Neither observations by the ENGINEER nor inspections, tests, or approvals by others shall relieve the CONTRACTOR from the CONTRACTOR's obligation to perform the WORK in accordance with the Contract Documents.
- D. All inspections, tests, or approvals other than those required by Laws or Regulations of any public body having jurisdiction shall be performed by organizations acceptable to the ENGINEER and the CONTRACTOR.
- E. If any work (including the work of others) that is to be inspected, tested, or approved is covered without written concurrence of the ENGINEER, it must, if requested by the ENGINEER, be uncovered for observation. Such uncovering shall be at the CONTRACTOR's expense unless the CONTRACTOR has given the ENGINEER timely notice of the CONTRACTOR's intention to perform such test or to cover the same and the ENGINEER has not acted with reasonable promptness in response to such notice.
- F. If any WORK is covered contrary to the written request of the ENGINEER, it must, if requested by the ENGINEER, be uncovered for the ENGINEER's observation and recovered at the CONTRACTOR's expense.
- G. If the ENGINEER considers it necessary or advisable that covered WORK be observed by the ENGINEER or inspected or tested by others, the CONTRACTOR, at the ENGINEER's request, shall uncover, expose, or otherwise make available for observation, inspection, or testing as the ENGINEER may require, that portion of the WORK in question, furnishing all necessary labor, material, and equipment. If it is found that such work is defective, the CONTRACTOR shall bear all direct, indirect, and consequential costs and damages of such uncovering, exposure, observation, inspection, and testing and of satisfactory reconstruction, including but not limited to fees and charges of engineers, attorneys, and other professionals. However, if such work is not found to be defective, the CONTRACTOR shall be allowed an increase in the Contract Price or an extension of the Contract Time, or both, directly attributable to such uncovering, exposure, observation, inspection, testing, and reconstruction; and, if the parties are unable to agree as to the amount or extent thereof, the CONTRACTOR may make a claim therefor as provided in Articles 11 and 12.

- 13.4 OWNER MAY STOP THE WORK. If the WORK is defective, or the CONTRACTOR fails to perform work in such a way that the completed WORK will conform to the Contract Documents, the OWNER may order the CONTRACTOR to stop the WORK, or any portion thereof, until the cause

SECTION 00700 - GENERAL CONDITIONS

for such order has been eliminated; however, this right of the OWNER to stop the WORK shall not give rise to any duty on the part of the OWNER to exercise this right for the benefit of the CONTRACTOR or any other party.

13.5 CORRECTION OR REMOVAL OF DEFECTIVE WORK. If required by the ENGINEER, the CONTRACTOR shall promptly, either correct all defective work, whether or not fabricated, installed, or completed, or, if the WORK has been rejected by the ENGINEER, remove it from the site and replace it with non-defective work. The CONTRACTOR shall bear all direct, indirect and consequential costs and damages of such correction or removal, including but not limited to fees and charges of engineers, attorneys, and other professionals made necessary thereby.

13.6 ONE YEAR CORRECTION PERIOD

A. If within one year after the date of Substantial Completion or such longer period of time as may be prescribed by Laws or Regulations or by the terms of any applicable special guarantee required by the Contract Documents or by any specific provision of the Contract Documents, any work is found to be defective, the CONTRACTOR shall promptly, without cost to the OWNER and in accordance with OWNER's written notification, (i) correct such Defective WORK, or, if it has been rejected by the OWNER, remove it from the site and replace it with non-defective work, and (ii) satisfactorily correct or remove and replace any damage to other work of others resulting therefrom. If the CONTRACTOR does not promptly comply with such notification, or in an emergency where delay would cause serious risk of loss or damage, the OWNER may have the Defective WORK corrected or the rejected WORK removed and replaced, and all direct, indirect, and consequential costs and damages of such removal and replacement including but not limited to fees and charges of engineers, attorneys and other professionals will be paid by the CONTRACTOR.

B. Where Defective WORK (and damage to other WORK resulting therefrom) has been corrected, removed or replaced under this paragraph 13.6, the correction period hereunder with respect to such WORK will be extended for an additional period of one year after such correction or removal and replacement has been satisfactorily completed.

13.7 ACCEPTANCE OF DEFECTIVE WORK. If, instead of requiring correction or removal and replacement of defective work, the OWNER prefers to accept the WORK, the OWNER may do so. The CONTRACTOR shall bear all direct, indirect, and consequential costs attributable to the OWNER's evaluation of and determination to accept such defective work. If any such acceptance occurs prior to final payment, a Change Order will be issued incorporating the necessary revisions in the Contract Documents with respect to the WORK, and the OWNER shall be entitled to an appropriate decrease in the Contract Price.

ARTICLE 14 PAYMENTS TO CONTRACTOR AND COMPLETION

14.1 SCHEDULE OF VALUES (LUMP SUM PRICE BREAKDOWN). The schedule of values or lump sum price breakdown established as provided in the General Requirements shall serve as the basis for progress payments and will be incorporated into a form of Application for Payment acceptable to the ENGINEER.

14.2 UNIT PRICE BID SCHEDULE. Progress payments on account of Unit Price work will be based on the number of units completed.

SECTION 00700 - GENERAL CONDITIONS

14.3 APPLICATION FOR PROGRESS PAYMENT

- A. Unless otherwise prescribed by law, on the 25th of each month, the CONTRACTOR shall submit to the ENGINEER for review, an Application for Payment filled out and signed by the CONTRACTOR covering the WORK completed as of the date of the Application and accompanied by such supporting documentation as is required by the Contract Documents.
- B. The Application for Payment shall identify, as a sub-total, the amount of the CONTRACTOR'S Total Earnings to Date, plus the Value of Materials Stored at the Site which have not yet been incorporated in the WORK, and less a deductive adjustment for materials installed which were not previously incorporated in the WORK, but for which payment was allowed under the provisions for payment for Materials Stored at the Site, but not yet incorporated in the WORK.
- C. The Net Payment Due the CONTRACTOR shall be the above-mentioned subtotal from which shall be deducted the total amount of all previous payments made to the CONTRACTOR. Progress payments will be paid in full in accordance with Article 14 of the General Conditions until 90% of the Contract Price has been paid. The remaining 10% of the Contract Price amount may be withheld until:
 - 1. final inspection has been made;
 - 2. completion of the project; and
 - 3. acceptance of the project by the OWNER.
- D. The Value of Materials Stored at the Site shall be an amount equal to the specified percent of the value of such materials as set forth in the Supplementary General Conditions. Said amount shall be based upon the value of all acceptable materials and equipment not incorporated in the WORK but delivered and suitably stored at the site or at another location agreed to in writing; provided, each such individual item has a value of more than \$5,000.00 and will become a permanent part of the WORK. The Application for Payment shall also be accompanied by an invoice (including shipping), a certification that the materials meet the applicable contract specifications, and any evidence required by the OWNER that the materials and equipment are covered by appropriate property insurance and other arrangements to protect the OWNER's interest therein, all of which will be satisfactory to the OWNER. Payment for materials will not constitute final acceptance. It shall be the CONTRACTOR's responsibility to protect the material from damage, theft, loss, or peril while in storage. Unless otherwise prescribed by law, the Value of Materials Stored at the Site shall be paid at the invoice amount up to a maximum of 85% of the Contract Price for those items.

14.4 CONTRACTOR'S WARRANTY OF TITLE. The CONTRACTOR warrants and guarantees that title to all work, materials, and equipment covered by an Application for Payment, whether incorporated in the WORK or not, will pass to the OWNER no later than the time of payment free and clear of all liens.

14.5 REVIEW OF APPLICATIONS FOR PROGRESS PAYMENT

- A. The ENGINEER will, within 7 days after receipt of each Application for Payment, either indicate in writing a recommendation of payment and present the Application to the OWNER,

SECTION 00700 - GENERAL CONDITIONS

or return the Application to the CONTRACTOR indicating in writing the ENGINEER's reasons for refusing to recommend payment. In the later case, the CONTRACTOR may make the necessary corrections and resubmit the Application, at which point the 7 days for ENGINEER review will begin again. If the ENGINEER still disagrees with a portion of the Application, it will submit the Application recommending the undisputed portion of the Application to the OWNER for payment and provide reasons for recommending non-payment of the disputed amount. Thirty days after presentation of the Application for Payment with the ENGINEER's recommendation, the amount recommended will (subject to the provisions of Paragraph 14.5B) become due and when due will be paid by the OWNER to the CONTRACTOR.

- B. The OWNER may refuse to make payment of the full amount recommended by the ENGINEER because claims have been made against the OWNER on account of the CONTRACTOR's performance of the WORK or Liens have been filed in connection with the WORK or there are other items entitling the OWNER to a credit against the amount recommended, but the OWNER must give the CONTRACTOR written notice within 7 days (with a copy to the ENGINEER) stating the reasons for such action.

14.6 PARTIAL UTILIZATION

- A. The OWNER shall have the right to utilize or place into service any item of equipment or other usable portion of the WORK prior to completion of the WORK. Whenever the OWNER plans to exercise said right, the CONTRACTOR will be notified in writing by the OWNER, identifying the specific portion or portions of the WORK to be so utilized or otherwise placed into service.
- B. It shall be understood by the CONTRACTOR that until such written notification is issued, all responsibility for care and maintenance of all of the WORK shall be borne by the CONTRACTOR. Upon issuance of said written notice of partial utilization, the OWNER will accept responsibility for the protection and maintenance of all such items or portions of the WORK described in the written notice.
- C. The CONTRACTOR shall retain full responsibility for satisfactory completion of the WORK, regardless of whether a portion thereof has been partially utilized by the OWNER and the CONTRACTOR's one year correction period shall commence only after the date of Substantial Completion for the WORK.

- 14.7 SUBSTANTIAL COMPLETION. When the CONTRACTOR considers the WORK ready for its intended use the CONTRACTOR shall notify the OWNER and the ENGINEER in writing that the WORK is substantially complete. The CONTRACTOR will attach to this request a list of all work items that remain to be completed and a request that the ENGINEER prepare a Notice of Completion. Within a reasonable time thereafter, the OWNER, the CONTRACTOR, and the ENGINEER shall make an inspection of the WORK to determine the status of completion. If the ENGINEER does not consider the WORK substantially complete, or the list of remaining work items to be comprehensive, the ENGINEER will notify the CONTRACTOR in writing giving the reasons therefor. If the ENGINEER considers the WORK substantially complete, the ENGINEER will prepare and deliver to the OWNER, for its execution and recording, the Notice of Completion signed by the ENGINEER and CONTRACTOR, which shall fix the date of Substantial Completion.

SECTION 00700 - GENERAL CONDITIONS

14.8 FINAL APPLICATION FOR PAYMENT. After the CONTRACTOR has completed all of the remaining work items referred to in Paragraph 14.7 and delivered all maintenance and operating instructions, schedules, guarantees, Bonds, certificates of inspection, record as-built documents (as provided in the General Requirements) and other documents, all as required by the Contract Documents, and after the ENGINEER has indicated that the WORK is acceptable, the CONTRACTOR may make application for final payment following the procedure for progress payments. The final Application for Payment shall be accompanied by all documentation called for in the Contract Documents, together with complete and legally effective releases or waivers (satisfactory to the OWNER) of all liens arising out of or filed in connection with the WORK.

14.9 FINAL PAYMENT AND ACCEPTANCE

- A. If, on the basis of the ENGINEER's observation of the WORK during construction and final inspection, and the ENGINEER's review of the final Application for Payment and accompanying documentation, all as required by the Contract Documents, the ENGINEER is satisfied that the WORK has been completed and the CONTRACTOR's other obligations under the Contract Documents have been fulfilled, the ENGINEER will, within 14 days after receipt of the final Application for Payment, indicate in writing the ENGINEER's recommendation of payment and present the Application to the OWNER for payment.
- B. After acceptance of the WORK by the OWNER's governing body, the OWNER will make final payment to the CONTRACTOR of the amount remaining after deducting all prior payments and all amounts to be kept or retained under the provisions of the Contract Documents, including the following items:
 - 1. Liquidated damages, as applicable.
 - 2. Two times the value of outstanding items of correction work or punch list items yet uncompleted or uncorrected, as applicable. All such work shall be completed or corrected to the satisfaction of the OWNER within the time stated on the Notice of Completion, otherwise the CONTRACTOR does hereby waive any and all claims to all monies withheld by the OWNER to cover the value of all such uncompleted or uncorrected items.

14.10 RELEASE OF RETAINAGE AND OTHER DEDUCTIONS

- A. After executing the necessary documents to initiate the lien period, and not more than 45 days thereafter (based on a 30-day lien filing period and 15-day processing time), the OWNER will release to the CONTRACTOR the retainage funds withheld pursuant to the Agreement, less any deductions to cover pending claims against the OWNER pursuant to Paragraph 14.5B.
- B. After filing of the necessary documents to initiate the lien period, the CONTRACTOR shall have 30 days to complete any outstanding items of correction work remaining to be completed or corrected as listed on a final punch list made a part of the Notice of Completion. Upon expiration of the 45 days, referred to in Paragraph 14.10A, the amounts withheld pursuant to the provisions of Paragraph 14.9B herein, for all remaining work items will be returned to the CONTRACTOR; provided, that said work has been completed or corrected to the satisfaction of the OWNER within said 30 days. Otherwise, the CONTRACTOR does hereby waive any and all claims for all monies withheld by the OWNER under the Contract to cover 2 times the value of such remaining uncompleted or uncorrected items.

SECTION 00700 - GENERAL CONDITIONS

- 14.11 **CONTRACTOR'S CONTINUING OBLIGATION.** The CONTRACTOR's obligation to perform and complete the WORK in accordance with the Contract Documents shall be absolute. Neither recommendation of any progress or final payment by the ENGINEER, nor the issuance of a Notice of Completion, nor any payment by the OWNER to the CONTRACTOR under the Contract Documents, nor any use or occupancy of the WORK or any part thereof by the OWNER, nor any act of acceptance by the OWNER nor any failure to do so, nor any review of a Shop Drawing or sample submittal, will constitute an acceptance of work not in accordance with the Contract Documents or a release of the CONTRACTOR's obligation to perform the WORK in accordance with the Contract Documents.
- 14.12 **FINAL PAYMENT TERMINATES LIABILITY OF OWNER.** Final payment is defined as the last progress payment made to the CONTRACTOR for earned funds, less monies withheld as applicable, pursuant to Paragraph 14.10A. The acceptance by the CONTRACTOR of the final payment referred to in Paragraph 14.9 herein, shall be a release of the OWNER and its agents from all claims of liability to the CONTRACTOR for anything done or furnished for, or relating to, the WORK or for any act of neglect of the OWNER or of any person relating to or affecting the WORK, except demands against the OWNER for the remainder, if any, of the amounts kept or retained under the provisions of Paragraph 14.9 herein; and excepting pending, unresolved claims filed prior to the date of the Notice of Completion.

ARTICLE 15 SUSPENSION OF WORK AND TERMINATION

- 15.1 **SUSPENSION OF WORK BY OWNER.** The OWNER, acting through the ENGINEER, may, at any time and without cause, suspend the WORK or any portion thereof for a period of not more than 90 days by notice in writing to the CONTRACTOR. The CONTRACTOR shall resume the WORK on receipt from the ENGINEER of a notice of resumption of work. The CONTRACTOR shall be allowed an increase in the Contract Price or an extension of the Contract Time, or both, directly attributable to any suspension if the CONTRACTOR makes an approved claim therefor as provided in Articles 11 and 12.
- 15.2 **TERMINATION OF AGREEMENT BY OWNER (CONTRACTOR DEFAULT)**
- A. In the event of default by the CONTRACTOR, the OWNER may give 10 days written notice to the CONTRACTOR of OWNER's intent to terminate the Agreement and provide the CONTRACTOR an opportunity to remedy the conditions constituting the default. It shall be considered a default by the CONTRACTOR whenever CONTRACTOR shall: (1) declare bankruptcy, become insolvent, or assign its assets for the benefit of its creditors; (2) fail to provide materials or quality of work meeting the requirements of the Contract Documents; (3) disregard or violate provisions of the Contract Documents or ENGINEER's instructions; (4) fail to prosecute the WORK according to the approved progress schedule; or, (5) fail to provide a qualified superintendent, competent workers, or materials or equipment meeting the requirements of the Contract Documents. If the CONTRACTOR fails to remedy the conditions constituting default within the time allowed, the OWNER may then issue the Notice of Termination.
- B. In the event the Agreement is terminated in accordance with Paragraph 15.2A, herein, the OWNER may take possession of the WORK and may complete the WORK by whatever method or means the OWNER may select. The cost of completing the WORK shall be deducted from the balance which would have been due the CONTRACTOR had the

SECTION 00700 - GENERAL CONDITIONS

Agreement not been terminated and the WORK completed in accordance with the Contract Documents. If such cost exceeds the balance which would have been due, the CONTRACTOR shall pay the excess amount to the OWNER. If such cost is less than the balance which would have been due, the CONTRACTOR shall not have claim to the difference.

- 15.3 TERMINATION OF AGREEMENT BY OWNER (FOR CONVENIENCE). The OWNER may terminate the Agreement at any time if it is found that reasons beyond the control of either the OWNER or CONTRACTOR make it impossible or against the OWNER's interests to complete the WORK. In such a case, the CONTRACTOR shall have no claims against the OWNER except: (1) for the value of work performed up to the date the Agreement is terminated; and, (2) for the cost of materials and equipment on hand, in transit, or on definite commitment, as of the date the Agreement is terminated which would be needed in the WORK and which meet the requirements of the Contract Documents. The value of work performed and the cost of materials and equipment delivered to the site, as mentioned above, shall be determined by the ENGINEER in accordance with the procedure prescribed for the making of the final application for payment and payment under Paragraphs 14.8 and 14.9.
- 15.4 TERMINATION OF AGREEMENT BY CONTRACTOR. The CONTRACTOR may terminate the Agreement upon 10 days written notice to the OWNER, whenever: 1) the WORK has been suspended under the provisions of Paragraph 15.1, herein, for more than 90 consecutive days through no fault or negligence of the CONTRACTOR, and notice to resume work or to terminate the Agreement has not been received from the OWNER within this time period; or, 2) the OWNER should fail to pay the CONTRACTOR any monies due him in accordance with the terms of the Contract Documents and within 60 days after presentation to the OWNER by the CONTRACTOR of a request therefor, unless within said 10-day period the OWNER shall have remedied the condition upon which the payment delay was based. In the event of such termination, the CONTRACTOR shall have no claims against the OWNER except for those claims specifically enumerated in Paragraph 15.3, herein, and as determined in accordance with the requirements of said paragraph.

ARTICLE 16 MISCELLANEOUS

- 16.1 GIVING NOTICE. Whenever any provision of the Contract Documents requires the giving of written notice, it will be deemed to have been validly given if delivered in person to the individual or to a member of the firm or to an officer of the corporation for whom it is intended, or if delivered at or sent by registered or certified mail, postage prepaid, to the last business address known to the giver of the notice.
- 16.2 RIGHTS IN AND USE OF MATERIALS FOUND ON THE WORK
- A. The CONTRACTOR may use on the Project, with ENGINEER's approval, such stone, gravel, sand, or other material determined suitable by the ENGINEER, as may be found in the excavation. The CONTRACTOR will be paid for the excavation of such material at the corresponding contract unit price. No additional payment will be made for utilizing the material from excavation as borrow, or select borrow.
- B. The CONTRACTOR shall replace, at its own expense, with other acceptable material, all of that portion of the excavated material so removed and used which was needed for use on the

SECTION 00700 - GENERAL CONDITIONS

project. No charge for the materials so used will be made against the CONTRACTOR except that the CONTRACTOR shall be responsible for payment of any royalties required.

- C. The CONTRACTOR shall not excavate or remove any material from within the Project location which is not within the grading limits, as indicated by the slope and grade lines, without written authorization from the ENGINEER.
 - D. In the event the CONTRACTOR has processed materials from OWNER-furnished sources in excess of the quantities required for performance of this contract, including any waste material produced as a by-product, the City and Borough of Wrangell may retain possession of such materials without obligation to reimburse the CONTRACTOR for the cost of their production. When such materials are in a stockpile, the ENGINEER may require: That it remain in stockpile; the CONTRACTOR level such stockpile(s); or that the CONTRACTOR remove such materials and restore the premises to a satisfactory condition at the CONTRACTOR's expense. This provision shall not preclude the City and Borough of Wrangell from arranging with the CONTRACTOR to produce material over and above the contract needs, payment for which shall be by written agreement between the City and Borough of Wrangell and the CONTRACTOR.
 - E. Unless otherwise provided, the material from any existing old structure may be used temporarily by the CONTRACTOR in the erection of the new structure. Such material shall not be cut or otherwise damaged except with the approval of the ENGINEER.
- 16.3 **RIGHT TO AUDIT.** If the CONTRACTOR submits a claim to the OWNER for additional compensation, the OWNER shall have the right, as a condition to considering the claim, and as a basis for evaluation of the claim, and until the claim has been settled, to audit the CONTRACTOR's books to the extent they are relevant. This right shall include the right to examine books, records, documents, and other evidence and accounting procedures and practices, sufficient to discover and verify all direct and indirect costs of whatever nature claimed to have been incurred or anticipated to be incurred and for which the claim has been submitted. The right to audit shall include the right to inspect the CONTRACTOR's plants, or such parts thereof, as may be or have been engaged in the performance of the WORK. The CONTRACTOR further agrees that the right to audit encompasses all subcontracts and is binding upon Subcontractors. The rights to examine and inspect herein provided for shall be exercisable through such representatives as the OWNER deems desirable during the CONTRACTOR's normal business hours at the office of the CONTRACTOR. The CONTRACTOR shall make available to the OWNER for auditing, all relevant accounting records and documents, and other financial data, and upon request, shall submit true copies of requested records to the OWNER.
- 16.4 **ARCHAEOLOGICAL OR HISTORICAL DISCOVERIES.** When the CONTRACTOR's operation encounters prehistoric artifacts, burials, remains of dwelling sites, paleontological remains, such as shell heaps, land or sea mammal bones or tusks, or other items of historical significance, the CONTRACTOR shall cease operations immediately and notify the ENGINEER. No artifacts or specimens shall be further disturbed or removed from the ground and no further operations shall be performed at the site until so directed. Should the ENGINEER order suspension of the CONTRACTOR's operations in order to protect an archaeological or historical finding, or order the CONTRACTOR to perform extra work, such order(s) shall be covered by an appropriate contract change document.

SECTION 00700 - GENERAL CONDITIONS

- 16.5 CONSTRUCTION OVER OR ADJACENT TO NAVIGABLE WATERS. All work over, on, or adjacent to navigable waters shall be so conducted that free navigation of the waterways will not be interfered with and the existing navigable depths will not be impaired, except as allowed by permit issued the U.S. Coast Guard and/or the U.S. Army Corps of Engineers, as applicable.
- 16.6 GRATUITY AND CONFLICT OF INTEREST. The CONTRACTOR agrees to not extend any loan, gratuity or gift of money of any form whatsoever to any employee or elected official of the OWNER
- 16.7 SUITS OF LAW CONCERNING THE WORK
- A. Should a suit of law be entered into, either by the CONTRACTOR (or the CONTRACTOR's surety) against the OWNER, or by the OWNER against the CONTRACTOR (or the CONTRACTOR's surety), the suit of law shall be tried in the First Judicial District of Alaska.
- B. If one of the questions at issue is the satisfactory performance of the work by the CONTRACTOR and should the appropriate court of law judge the work of the CONTRACTOR to be unsatisfactory, then the CONTRACTOR (or the CONTRACTOR's surety) shall reimburse the OWNER for all legal and all other expenses (as may be allowed and set by the court) incurred by the OWNER because of the suit of the law and, further, it is agreed that the OWNER may deduct such expense from any sum or sums then, or any that become due the CONTRACTOR under the contract.
- 16.8 CERTIFIED PAYROLLS
- A. All CONTRACTORs or Subcontractor who perform work on a public construction contract for the OWNER shall file a certified payroll with the Alaska Department of Labor before Friday of each week that covers the preceding week (Section 14-2-4 ACLA 1949; am Section 4 ch 142 SLA 1972).
- B. In lieu of submitting the State payroll form, the CONTRACTOR's standard payroll form may be submitted, provided it contains the information required by AS 36.05.040 and a statement that the CONTRACTOR is complying with AS 36.10.010.
- C. A CONTRACTOR or Subcontractor, who performs work on public construction in the State, as defined by AS 36.95.010(3), shall pay not less than the current prevailing rate of wages as issued by the Alaska Department of Labor before the end of the pay period. (AS 36.05.010).
- 16.9 PREVAILING WAGE RATES
- A. Wage rates for Laborers and Mechanics on Public Contracts, AS 36.05.070. The CONTRACTOR, or Subcontractors, shall pay all employees unconditionally and not less than once a week. Wages may not be less than those stated in Paragraph 16.8C, regardless of the contractual relationship between the CONTRACTOR or Subcontractors and laborers, mechanics, or field surveyors. The scale of wages to be paid shall be posted by the CONTRACTOR in a prominent, easily accessible place at the site of the WORK.
- B. Failure to Pay Agreed Wages, AS 36.05.080. If it is found that a laborer, mechanic, or field surveyor employed by the CONTRACTOR or Subcontractor has been, or is being, paid a rate or wages less than the established rate, the OWNER may, by written notice, terminate the

SECTION 00700 - GENERAL CONDITIONS

CONTRACTOR or Subcontractors right to proceed with the work. The OWNER may prosecute the work to completion by contract or otherwise, and the CONTRACTOR and sureties will be held liable to the OWNER for excess costs for completing the WORK. (Section 2 ch 52 SLA 1959).

- C. Listing CONTRACTOR's Who Violate Contracts, AS 36.05.090. In addition, a list giving the names of persons who have disregarded the rights of their employees shall be distributed to all departments of State government and all political subdivisions. No person appearing on this list, and no firm, corporation, partnership or association in which the person has an interest, may work as a CONTRACTOR or Subcontractor on a public construction contract for the State, or a political subdivision of the state, until three years after the date of publication of the list. (Section 3 ch 52 SLA 1959; am Section 9 ch 142 SLA).

16.10 EMPLOYMENT REFERENCE. Workers employed in the execution of the contract by the CONTRACTOR or by any Subcontractor under this contract shall not be required or permitted to labor more than 8 hours a day or 40 hours per week in violation of the provisions of the Alaska Wage and Hour Act, Section 23.10.060.

16.11 COST REDUCTION INCENTIVE

- A. At any time within 45 days after the date of the Notice of Award, the CONTRACTOR may submit to the ENGINEER in writing, proposals for modifying the plans, specifications, or other requirements of this contract for the sole purpose of reducing the total cost of construction. The cost reduction proposal shall not impair in any manner the essential functions or characteristics of the project, including but not limited to, service life, economy of operation, ease of maintenance, desired appearance or design and safety standards.
- B. The cost reduction proposal shall contain the following information:
1. Description of both the existing contract requirements for performing the WORK and the proposed changes.
 2. An itemization of the contract requirements that must be changed if the proposal is adopted.
 3. A detailed estimate of the time required and the cost of performing the WORK under both the existing contract and the proposed change.
 4. A statement of the date by which the CONTRACTOR must receive the decision from the OWNER on the cost reduction proposal.
 5. The contract items of WORK effected by the proposed changes including any quantity variations.
 6. A description and estimate of costs the OWNER may incur in implementing the proposed changes, such as test and evaluation and operating and support costs.
 7. A prediction of any effects the proposed change would have on future operations and maintenance costs to the OWNER.
- C. The provisions of this section shall not be construed to require the OWNER to consider any cost reduction proposal which may be submitted; nor will the OWNER be liable to the CONTRACTOR for failure to accept or act upon any cost reduction proposal submitted, or for delays to the work attributable to the consideration or implementation of any such proposal.

SECTION 00700 - GENERAL CONDITIONS

- D. If a cost reduction proposal is similar to a change in the plans or specifications for the project under consideration by the OWNER at the time the proposal is submitted, the OWNER will not accept such proposal and reserves the right to make such changes without compensation to the CONTRACTOR under the provisions of this section.
- E. The CONTRACTOR shall continue to perform the work in accordance with the requirements of the contract until an executed Change Order incorporating the cost reduction proposal has been issued. If any executed Change Order has not been issued by the date upon which the CONTRACTOR's cost reduction proposal specifies that a decision should be made by the OWNER, in writing, the cost reduction proposal shall be considered rejected.
- F. The OWNER, shall be the sole judge of the acceptability of a cost reduction proposal and of the estimated net savings in Contract Time and construction costs resulting from the adoption of all or any part of such proposal. Should the CONTRACTOR disagree with OWNER's decision on the cost reduction proposal, there is no further consideration. The OWNER reserves the right to make final determination.
- G. If the CONTRACTOR's cost reduction proposal is accepted in whole or in part, such acceptance will be made by a contract Change Order, which specifically states that the change is executed pursuant to this cost reduction proposal section. Such Change Order shall incorporate the changes in the plans and specifications which are necessary to permit the cost reduction proposal or such part of it as has been accepted to be put into effect and shall include any conditions upon which the OWNER's approval is based, if such approval is conditional. The Change Order shall also describe the estimated net savings in the cost of performing the work attributable to the cost reduction proposal, and shall further provide that the contract cost be adjusted by crediting the OWNER with the estimated net savings amount.
- H. Acceptance of the cost reduction proposal and performance of the work does not extend the time of completion of the contract, unless specifically provided in the Change Order authorizing the use of the submitted proposal. Should the adoption of the cost reduction proposal result in a Contract Time savings, the total Contract Time shall be reduced by an amount equal to the time savings realized.
- I. The amount specified to the CONTRACTOR in the Change Order accepted in the cost reduction proposal shall constitute full compensation for the performance of WORK. No claims for additional costs as a result of the changes specified in the cost reduction proposal shall be allowed.
- J. The OWNER reserves the right to adopt and utilize any approved cost reduction proposal for general use on any contract administered when it is determined suitable for such application. Cost reduction proposals identical, similar, or previously submitted will not be accepted for consideration if acceptance and compensation has previously been approved. The OWNER reserves the right to use all or part of any cost reduction proposal without obligation or compensation of any kind to the CONTRACTOR.
- K. The CONTRACTOR shall bear the costs, if any, to revise all bonds and insurance requirements for the project, to include the cost reduction WORK.

END OF SECTION

SECTION 00800 - SUPPLEMENTARY GENERAL CONDITIONS

GENERAL. These Supplementary General Conditions make additions, deletions, or revisions to the General Conditions as indicated herein. All provisions which are not so added, deleted, or revised remain in full force and effect. Terms used in these Supplementary General Conditions which are defined in the General Conditions have the meanings assigned to them in the General Conditions.

SGC 2.2 COPIES OF DOCUMENTS. *Add* the following:

The OWNER shall furnish to the CONTRACTOR up to 5 copies of the Contract Documents which may include bound reduced Drawings. (Note: Full size drawings (22"x36") are not available for this project.) Additional quantities of the Contract Documents will be furnished at reproduction cost.

SGC 4.2 PHYSICAL CONDITIONS - SUBSURFACE AND EXISTING STRUCTURES. *Add* the following:

In the preparation of the Contract Documents, the Engineer of Record has relied upon:

1. The following report of exploration and tests of subsurface conditions at the site of the WORK:
 - a. Field measurements and visual inspection of the existing structures and surface conditions.

SGC 5.2 INSURANCE AMOUNTS. The limits of liability for the insurance required by Paragraph 5.2 of the General Conditions shall provide coverage for not less than the following amounts or greater where required by Laws and Regulations:

A. Workers' Compensation: (under Paragraph 5.2C.1 of the General Conditions) as in accordance with AS 23.30.045:

1. State: Statutory
2. Applicable Federal (e.g., Longshore): Statutory

Note: If the WORK called for in the Contract Documents involves work in or on any navigable waters, the CONTRACTOR shall provide Workers' Compensation coverage which shall include coverage under the Longshore and Harbor Workers' Compensation Act, the Jones Act, and any other coverage required under Federal or State laws pertaining to workers in or on navigable waters.

3. Employers Liability

Bodily Injury by Accident:	\$100,000.00	Each Accident
Bodily Injury by Disease:	\$100,000.00	Each Employee
Bodily Injury by Disease:	\$500,000.00	Policy Limit

- a. CONTRACTOR agrees to waive all rights of subrogation against the OWNER and ENGINEER for work performed under Contract.
- b. If CONTRACTOR directly utilizes labor outside of the State of Alaska in the prosecution of the WORK, "Other States" endorsement shall be required as a condition of the Contract.

SECTION 00800 - SUPPLEMENTARY GENERAL CONDITIONS

- B. Commercial General Liability: (under Paragraph 5.2C.2 of the General Conditions):
 - 1. Combined Single Limit
 - a. General Policy \$1,000,000.00 Each Occurrence
\$2,000,000.00 Annual Aggregate
 - b. Products/Completed Operations \$1,000,000.00 Each Occurrence
\$2,000,000.00 Annual Aggregate
 - c. Personal Injury \$1,000,000.00 Each Occurrence
- C. Commercial Automobile Liability: (under Paragraph 5.2C.3 of the General Conditions) including Owned, Hired, and Non-Owned Vehicles:

Combined Single Limit, Bodily Injury and Property Damage \$1,000,000.00
- D. Marine Protection and Indemnity: \$1,000,000.00 per Accident or Occurrence. Divers must have appropriate certifications.
- E. Policies shall also specify insurance provided by CONTRACTOR will be considered primary and not contributory to any other insurance available to the OWNER or the ENGINEER.
- F. All policies will provide for 30 (thirty) days written notice prior to any cancellation or non-renewal of insurance policies required under Contract except in the event of no-payment of premium where 10 (ten) days is permissible.
- G. The City and Borough of Wrangell shall be named as an "Additional Insured" under all liability coverages listed in this Section, except for workers' compensation insurance.

SGC 14.9 FINAL PAYMENT AND ACCEPTANCE. *Add* the following paragraph:

- B. Prior to the final payment the CONTRACTOR shall contact the Alaska Department of Labor (ADOL) and provide the OWNER with clearance from the ADOL for the CONTRACTOR and all Subcontractors that have worked on the Project. This clearance shall indicate that all Employment Security Taxes have been paid. A sample letter for this purpose is at the end of this section.

SGC 16.8 CERTIFIED PAYROLLS. *Change* paragraph A. to read:

- A. All CONTRACTORS and Subcontractors shall conform to State of Alaska's Title 36 Public Contract Requirements as published in the Wage and Hour Administration Pamphlet 400 latest edition.
- B. All CONTRACTORS or Subcontractors who perform work on a public construction contract for the OWNER shall file a certified payroll with Alaska Department of Labor. See Section 00830 - Alaska Labor Standards, Reporting, and Prevailing Wage Rate Determination.

Date: _____

To: Alaska Department of Labor
Juneau Field Tax Office

**WRANGELL MARINE SERVICE CENTER
BOAT HAULOUT PIER STRUCTURAL UPGRADES**

**SUPPLEMENTARY
GENERAL CONDITIONS
Page 00800 - 2**

SECTION 00800 - SUPPLEMENTARY GENERAL CONDITIONS

FAX 907-465-2374

From: _____

Subject WRANGELL MARINE SERVICE CENTER – BOAT HAULOUT PIER STRUCTURAL UPGRADES

Timeframe of Contract _____

Please advise whether or not clearance is granted for the following CONTRACTOR or Subcontractor:

Name Address

Per AS 23.20.265 of the Alaska Employment Security Act, this request is for tax liability clearance and release to make final payment for WORK performed under the subject contract. Please send your response to:

Timothy Rooney, Borough Manager
City and Borough of Wrangell
PO Box 531
Wrangell, Alaska 99929
Telephone: (907) 874-2381
Fax: (907) 874-3952

- () Tax Clearance is granted.
- () Tax Clearance is NOT granted.

Remarks: _____

Signature Date

Title

END OF SECTION

**SECTION 00830 - ALASKA LABOR STANDARDS, REPORTING, AND
PREVAILING WAGE RATE DETERMINATION**

State of Alaska, AS 36.05, Department of Labor, Laborers' and Mechanics' Minimum Rates of Pay, AS 36.05.010, and AS 36.05.050, Wage and Hour Administration Pamphlet No. 600, the latest edition published by the State of Alaska, Department of Labor inclusive, are made a part of this contract by reference.

The CONTRACTOR is responsible for contacting the Alaska Department of Labor to determine compliance with current regulations.

Required Reporting During Contract (to be provided by every CONTRACTOR and Subcontractor):

- A. **Certified Payrolls must be submitted every two weeks. Before the second Friday**, each CONTRACTOR and Subcontractor must file Certified Payrolls with Statements of Compliance for the previous two weeks. If there was no activity for that pay period, indicate "**No Activity.**" Indicate "**Start**" on your first payroll, and "**Final**" on your last payroll for this Project. Send to:

Wage and Hour Section
Labor Law Compliance Division
Alaska Department of Labor
P.O. Box 020630
Juneau, AK 99802-0630
(907) 465-4842

and

Amber Al-Haddad, Project Manager
City & Borough of Wrangell
P.O. Box 531
Wrangell, AK 99929
T 907.874.3494 / F 907.874.2699
Email wrgpm@wrangell.com

- B. **Within 10 Days of "Notice of Award/Notice to Proceed"** make a list of **all** Subcontractors. Include their name, address, phone, estimated subcontract amount, and estimated start and finish dates. Send to:

Amber Al-Haddad, Project Manager
City & Borough of Wrangell
P.O. Box 531
Wrangell, AK 99929
T 907.874.3494 / F 907.874.2699
Email wrgpm@wrangell.com

and

Wage and Hour Section
Labor Law Compliance Division
Alaska Department of Labor
P.O. Box 020630
Juneau, AK 99802-0630
(907) 465-4839/4842

- C. Per AS 36.05 the Contractor shall file a Notice of Work and a Notice of Completion. AS 36.05 can be found at the following link: <http://labor.alaska.gov/lss/forms/Pam400.pdf>

- D. As part of the **final payment request package**:

A completed Compliance Certificate and Release form (provided in Section 01700 - Project Closeout) from every CONTRACTOR and Subcontractor.

Notice of Completion of Public Works from the Department of Labor (Section 01700 – Project Closeout)

A tax clearance from the Department of Labor is required (Section 01700 - Project Closeout)

END OF SECTION

SECTION 00852 – PERMITS

PART 1 – GENERAL

INDEX OF PERMITS

1. Department of the Army, Nationwide Permit, see attached pages.

PART 2 - PRODUCTS (Not Used)

PART 3 - EXECUTION (Not Used)

END OF SECTION

Do you intend to use any other authorizations for any part of the proposed project or any related activity, for example, a NWP, General Permit (GP), or Individual Permit (IP)?

YES or NO

If YES, specify what permit type (NWP, GP, IP) and for what aspect of the project:

Nationwide Permit 3 - Maintenance

Will your proposed project result in the loss of greater than 1/10 of an acre of wetlands?

YES or NO

If YES, describe how you will satisfy the mitigation requirement in Nationwide Permit General Condition 23 (attached). If additional space is needed, please attach sheets.

Are there any listed species or designated critical habitat that might be affected or is in the vicinity of the project, or is the project located in designated critical habitat? Federal agencies must provide the appropriate documentation to demonstrate compliance with the agency's procedures for compliance with the ESA. Information on the location of threatened or endangered species and their critical habitat can be obtained directly from the offices of the U.S. Fish and Wildlife Service and the National Marine Fisheries Service.

YES or NO

If YES, list all species:

Are there historic properties (listed on, determined to be eligible for listing on, or potentially eligible for listing on the National Register of Historic Places, including previously unidentified properties) that the proposed activity may have the potential to effect? Federal agencies must provide documentation demonstrating compliance with the Section 106 of the National Historic Preservation Act. Assistance regarding information on the location of or potential for the presence of historic resources can be sought from the State Historic Preservation Officer.

YES or NO

If YES, state which property or properties may be affected and/or attach a vicinity map indicating the location of the historic property or properties.

Will the proposed work involve ground disturbing activities?

YES or NO

If YES, attach a short narrative describing the topsoil or organic materials (including seed) that you intend to use for rehabilitation. If you intend to use other locally-obtained native materials, identify the source.

Attach the following in addition to the above applicable items:

- Drawings of the site and project plans (For more information on acceptable drawings and plans, please visit our website at <http://www.poa.usace.army.mil/req/permitapp.htm> and click on "Guide to Drawings")
- The PCN must include a delineation of wetlands, other special aquatic sites (riffle and pool complexes, sanctuaries and refuges, mudflats, vegetated shallows, and/or coral reefs), and other waters, such as lakes and ponds, and perennial, intermittent, and ephemeral streams, on the project site. Wetland delineations must be prepared in accordance with the current method required by the Corps. The applicant may request the Corps to delineate the special aquatic sites and other waters and if the PCN does not include a delineation we will take that to mean you are requesting the Corps for one. In these cases, the PCN will not be considered complete until we complete the delineation.

Note: If you request a Corps delineation, you may be delayed in receiving authorization for your proposed project.

Application is hereby made for a permit or permits to authorize the work described in this preconstruction notification form.

I certify the information in this preconstruction notification form is complete and accurate. I further certify that I possess the authority to undertake the work described herein or am acting as the duly authorized agent of the applicant.

Carl Holm

SIGNATURE OF APPLICANT

3-14-13

DATE

SIGNATURE OF AGENT

DATE

NATIONWIDE PERMIT GENERAL CONDITION 23: MITIGATION

The district engineer will consider the following factors when determining appropriate and practicable mitigation necessary to ensure that adverse effects on the aquatic environment are minimal:

(a) The activity must be designed and constructed to avoid and minimize adverse effects, both temporary and permanent, to waters of the United States to the maximum extent practicable at the project site (i.e., on site).

(b) Mitigation in all its forms (avoiding, minimizing, rectifying, reducing, or compensating for resource losses) will be required to the extent necessary to ensure that the adverse effects to the aquatic environment are minimal.

(c) Compensatory mitigation at a minimum one-for-one ratio will be required for all wetland losses that exceed 1/10-acre and require preconstruction notification, unless the district engineer determines in writing that either some other form of mitigation would be more environmentally appropriate or the adverse effects of the proposed activity are minimal, and provides a project-specific waiver of this requirement. For wetland losses of 1/10-acre or less that require pre-construction notification, the district engineer may determine on a case-by-case basis that compensatory mitigation is required to ensure that the activity results in minimal adverse effects on the aquatic environment. Compensatory mitigation projects provided to offset losses of aquatic resources must comply with the applicable provisions of 33 CFR part 332.

(1) The prospective permittee is responsible for proposing an appropriate compensatory mitigation option if compensatory mitigation is necessary to ensure that the activity results in minimal adverse effects on the aquatic environment.

(2) Since the likelihood of success is greater and the impacts to potentially valuable uplands are reduced, wetland restoration should be the first compensatory mitigation option considered.

(3) If permittee-responsible mitigation is the proposed option, the prospective permittee is responsible for submitting a mitigation plan. A conceptual or detailed mitigation plan may be used by the district engineer to make the decision on the NWP verification request, but a final mitigation plan that addresses the applicable requirements of 33 CFR 332.4(c)(2)–(14) must be approved by the district engineer before the permittee begins work in waters of the United States, unless the district engineer determines that prior approval of the final mitigation plan is not practicable or not necessary to ensure timely completion of the required compensatory mitigation (see 33 CFR 332.3(k)(3)).

(4) If mitigation bank or in-lieu fee program credits are the proposed option, the mitigation plan only needs to address the baseline conditions at the impact site and the number of credits to be provided.

(5) Compensatory mitigation requirements (e.g., resource type and amount to be provided as compensatory mitigation, site protection, ecological performance standards, monitoring requirements) may be addressed through conditions added to the NWP authorization, instead of components of a compensatory mitigation plan.

(d) For losses of streams or other open waters that require pre-construction notification, the district engineer may require compensatory mitigation, such as stream rehabilitation, enhancement, or preservation, to ensure that the activity results in minimal adverse effects on the aquatic environment.

(e) Compensatory mitigation will not be used to increase the acreage losses allowed by the acreage limits of the NWPs. For example, if an NWP has an acreage limit of 1/2-acre, it cannot be used to authorize any project resulting in the loss of greater than 1/2-acre of waters of the United States, even if compensatory mitigation is provided that replaces or restores some of the lost waters. However, compensatory mitigation can and should be used, as necessary, to

ensure that a project already meeting the established acreage limits also satisfies the minimal impact requirement associated with the NWP.

(f) Compensatory mitigation plans for projects in or near streams or other open waters will normally include a requirement for the restoration or establishment, maintenance, and legal protection (e.g., conservation easements) of riparian areas next to open waters. In some cases, riparian areas may be the only compensatory mitigation required. Riparian areas should consist of native species. The width of the required riparian area will address documented water quality or aquatic habitat loss concerns. Normally, the riparian area will be 25 to 50 feet wide on each side of the stream, but the district engineer may require slightly wider riparian areas to address documented water quality or habitat loss concerns. If it is not possible to establish a riparian area on both sides of a stream, or if the waterbody is a lake or coastal waters, then restoring or establishing a riparian area along a single bank or shoreline may be sufficient. Where both wetlands and open waters exist on the project site, the district engineer will determine the appropriate compensatory mitigation (e.g., riparian areas and/or wetlands compensation) based on what is best for the aquatic environment on a watershed basis. In cases where riparian areas are determined to be the most appropriate form of compensatory mitigation, the district engineer may waive or reduce the requirement to provide wetland compensatory mitigation for wetland losses.

(g) Permittees may propose the use of mitigation banks, in-lieu fee programs, or separate permittee-responsible mitigation. For activities resulting in the loss of marine or estuarine resources, permittee-responsible compensatory mitigation may be environmentally preferable if there are no mitigation banks or in-lieu fee programs in the area that have marine or estuarine credits available for sale or transfer to the permittee. For permittee-responsible mitigation, the special conditions of the NWP verification must clearly indicate the party or parties responsible for the implementation and performance of the compensatory mitigation project, and, if required, its long-term management.

(h) Where certain functions and services of waters of the United States are permanently adversely affected, such as the conversion of a forested or scrub-shrub wetland to a herbaceous wetland in a permanently maintained utility line right-of-way, mitigation may be required to reduce the adverse effects of the project to the minimal level.

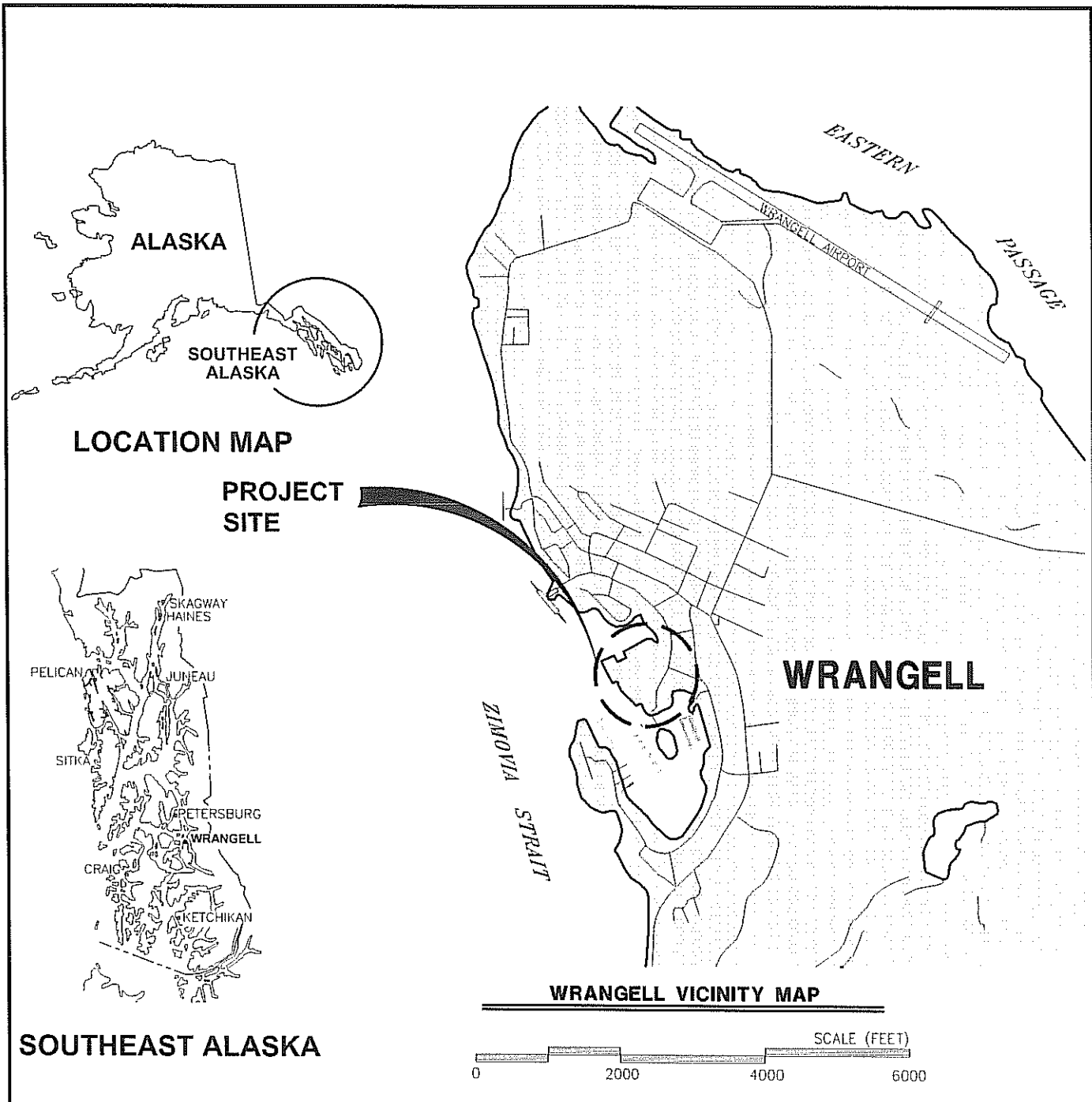

SOUTHEAST ALASKA

WRANGELL VICINITY MAP

PURPOSE: TO INCREASE CAPACITY TO ALLOW FOR INCREASED LIFT DEMANDS

DATUM: HTL = 19.5'
MHW = 14.8'
MLLW = 0.0 FT MLLW = 0.0'

WRANGELL MARINE SERVICE CENTER

BOAT HAUL-OUT PIER
STRUCTURAL UPGRADES

PND PROJECT NO. 122056.01

APPLICANT: CITY AND BOROUGH OF WRANGELL
FILE NO.:
WATERWAY: ZIMOVIA STRAIT
PROPOSED ACTIVITY: BOAT LIFT UPGRADES
SEC. 25 T. 62S R. 83E M. CRM
LAT.: 56.468086°N LONG.: 132.384186°W
DATE: MAR 2013

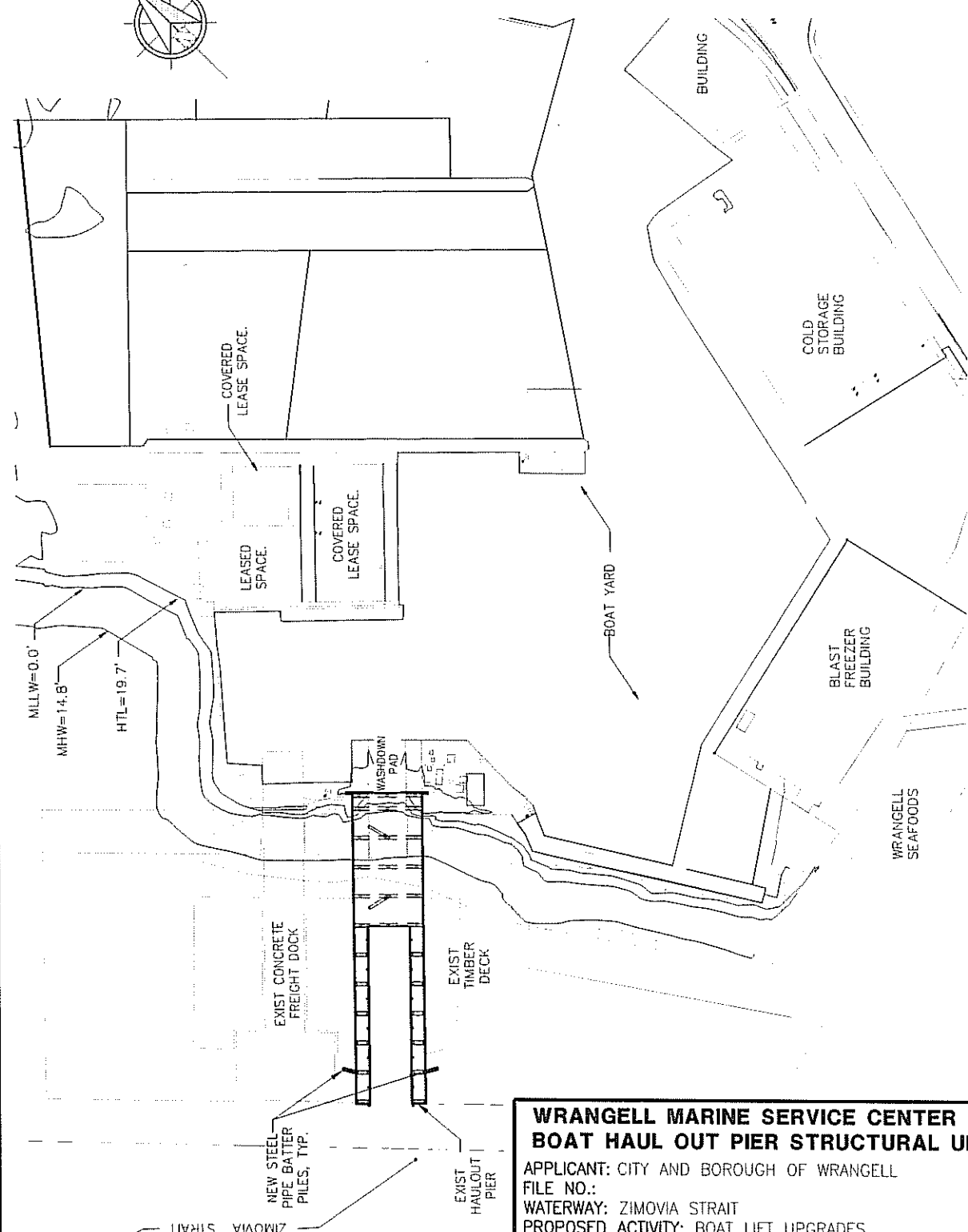
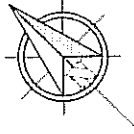

EXISTING CONDITIONS AND SITE PLAN



DATUM:
HTL = 19.5'
MHW = 14.8'
MLLW = 0.0'

**WRANGELL MARINE SERVICE CENTER
BOAT HAUL OUT PIER STRUCTURAL UPGRADES**

APPLICANT: CITY AND BOROUGH OF WRANGELL
FILE NO.:
WATERWAY: ZIMOVIA STRAIT
PROPOSED ACTIVITY: BOAT LIFT UPGRADES
SEC. 25 T. 62S R. 83E M CRM
LAT.: 56.468086°N LONG.: 132.384186°W
DATE: MAR 2013

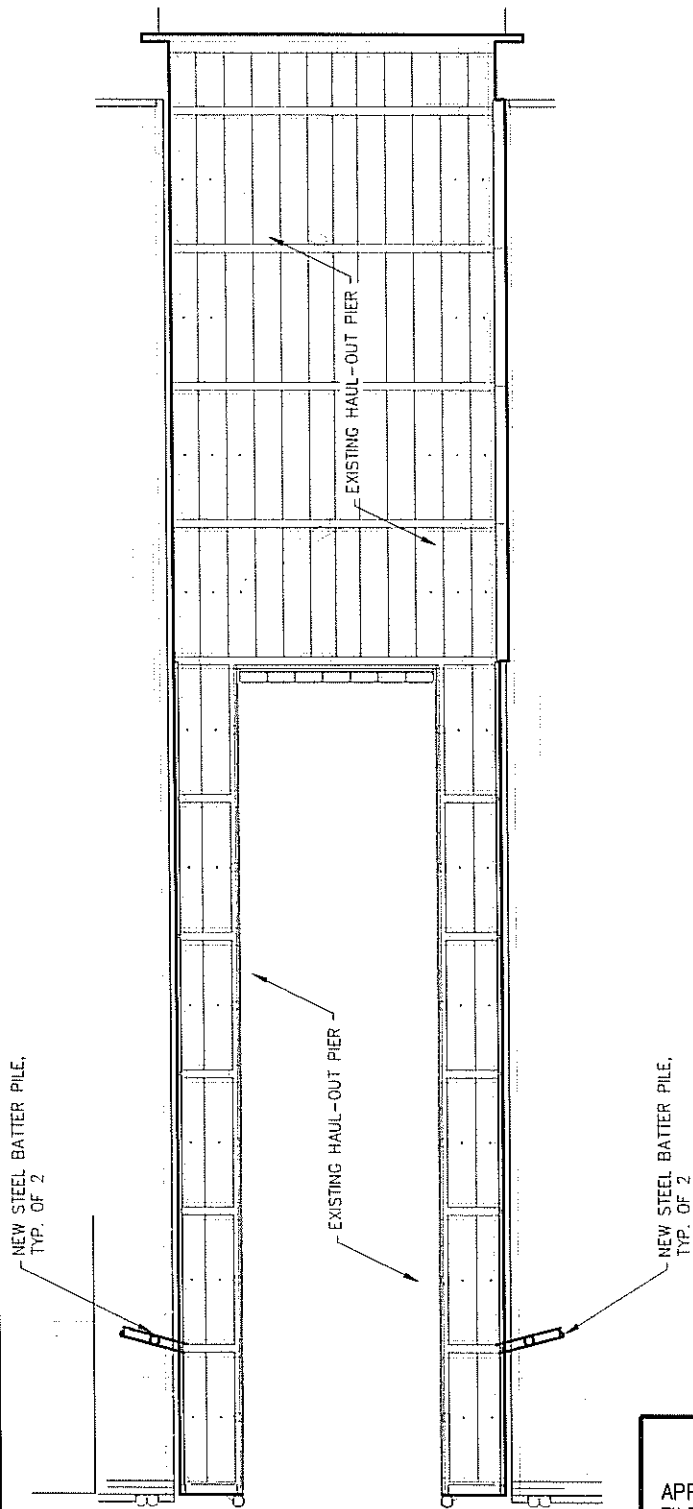
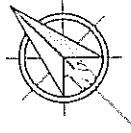

DOCK PLAN



APPLICANT: CITY AND BOROUGH OF WRANGELL
FILE NO.:
WATERWAY: ZIMOVIA STRAIT
PROPOSED ACTIVITY: BOAT LIFT UPGRADES
SEC. 25 T. 62S R. 83E M CRM
LAT.: 56.468086°N LONG.: 132.384186°W
DATE: MAR 2013

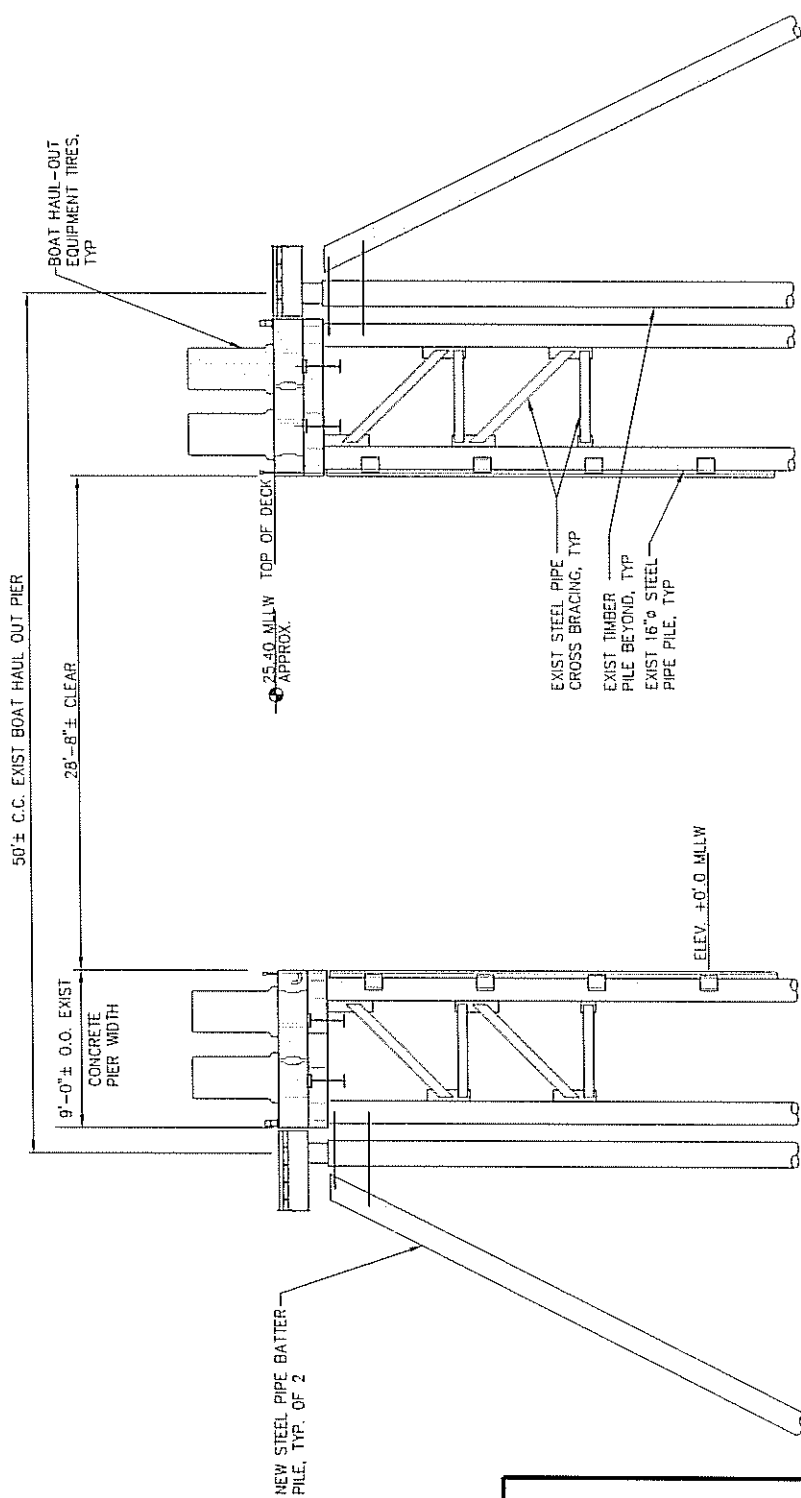

A TYPICAL SECTION



APPLICANT: CITY AND BOROUGH OF WRANGELL
 FILE NO.:
 WATERWAY: ZIMOVIA STRAIT
 PROPOSED ACTIVITY: BOAT LIFT UPGRADES
 SEC. 25 T. 62S R. 83E M CRM
 LAT.: 56.468086°N LONG.: 132.384186°W
 DATE: MAR 2013

SECTION 01010 - SUMMARY OF WORK

PART 1 – GENERAL

1.1 GENERAL

- A. The WORK to be performed under this contract shall consist of furnishing all plant, tools, equipment, materials, supplies, manufactured articles, labor, transportation and services, including fuel, power, water, and essential communications, and performing all WORK, or other operations required for the fulfillment of the contract in strict accordance with the Contract Documents. The WORK shall be complete, and all work, materials, and services not expressly indicated or called for in the Contract Documents which may be necessary for the complete and proper construction of the WORK in good faith shall be provided by the CONTRACTOR as though originally so indicated, at no increase in cost to the OWNER.

1.2 WORK COVERED BY CONTRACT DOCUMENTS

- A. The WORK consists of all activities necessary to construct the Wrangell Marine Service Center Boat Haulout Pier Structural Upgrades. The facility includes demolition and repair of an existing timber deck for pile installation and strengthening the concrete deck from below by installing steel beams and grouting between the beams and the concrete deck.

1.3 SITE OF THE WORK

- A. The site of the WORK is located in down town Wrangell, Alaska adjacent to the Nolan Center and Wrangell Seafoods.

1.4 BEGINNING AND COMPLETION OF THE WORK

- A. The sequencing time frame s are the essence of the contract. In accordance with the provisions of Article 2 of SECTION 00500 - AGREEMENT, the CONTRACTOR shall begin the WORK on the date specified in the written Notice to Proceed from the OWNER, and shall complete all the WORK in accordance with the following schedule:

DESCRIPTION (ITEM)	EARLIEST START (DATE)	SUBSTANTIAL COMPLETION (DATE)
SUBSTANTIAL COMPLETION	NOTICE TO PROCEED (NTP)	October 1, 2013
FINAL COMPLETION		November 1, 2013

1.5 CONTRACT METHOD

- A. The WORK hereunder will be constructed under a unit-price Contract.

1.6 WORK by Others

- A. The CONTRACTOR's attention is directed to the fact that WORK may be conducted at the site by other contractors during the performance of the WORK under this Contract. The CONTRACTOR shall conduct its operations so as to cause a minimum of interference with the WORK of such other Contractors, and shall cooperate fully with such Contractors to provide continued safe access to their respective portions of the site, as required to perform WORK under their respective contracts.
- B. Interference With WORK On Utilities: The CONTRACTOR shall cooperate fully with all utility forces of the OWNER or forces of other public or private agencies engaged in

SECTION 01010 - SUMMARY OF WORK

the relocation, altering, or otherwise rearranging of any facilities which interfere with the progress of the WORK, and shall schedule the WORK so as to minimize interference with said relocation, altering, or other rearranging of facilities.

1.7 CONTRACTOR USE OF PROJECT SITE

- A. The CONTRACTOR's use of the Project site shall be limited to its construction operations, including on-site storage of materials. The CONTRACTOR shall coordinate with the OWNER for final staging area limits.
- B. The CONTRACTOR shall have total access to the pier and haulout bay on Friday, Saturday and Sunday each week. The OWNER has use of the haulout pier Monday through Thursday from 7:30 am to 3:30 pm. The CONTRACTOR may work under the pier during the OWNER's use if and only if the bay remains clear and lifting of boats is accommodated.
- C. The CONTRACTOR shall coordinate and accommodate access at the face of the dock and through the site for weekly AML barge service to Wrangell.
- D. The CONTRACTOR operations shall not occupy the entire site and close coordination with the OWNER must be maintained to accommodate active boat yard operations, including access to vessels, trailer maneuvers, storage, boat haulouts and emergency vehicle access shall be maintained.

1.8 OWNER USE OF THE PROJECT SITE

- A. The OWNER shall utilize all or part of the existing site during the entire period of construction for the conduct of the OWNER's normal operations. The site is an active boat yard and operations will be on going the entire construction period. The CONTRACTOR shall cooperate and coordinate with the ENGINEER to facilitate the OWNER's operations and to minimize interference with the CONTRACTOR's operations at the same time. In any event, the OWNER shall be allowed full access to the entire Project site during the period of construction.

1.9 PROJECT MEETINGS

- A. Pre-Construction Conference
 - 1. Prior to the commencement of WORK at the site, a Pre-Construction Conference will be held at a mutually agreed time and place which shall be attended by the CONTRACTOR's Project manager, its superintendent, and its Subcontractors as the CONTRACTOR deems appropriate. Other attendants will be:
 - a. ENGINEER and the Inspector.
 - b. Representatives of OWNER.
 - c. Governmental representatives as appropriate.
 - d. Others as requested by CONTRACTOR, OWNER, or ENGINEER.
 - 2. Unless previously submitted to the ENGINEER, the CONTRACTOR shall bring one copy each of the following:
 - a. Plan of Operation.
 - b. Project Overview Bar Chart Schedule based on Critical Path scheduling.
 - c. Procurement schedule of major equipment and materials and items requiring long lead time.
 - d. Shop Drawing/Sample/Substitute or "Or Equal" submittal schedule.
 - e. Name and telephone number of CONTRACTOR's

SECTION 01010 - SUMMARY OF WORK

- f. Project Supervisor.
Schedule of Values.

- 3. The purpose of the Pre-Construction Conference is to designate responsible personnel and establish a working relationship. Matters requiring coordination will be discussed and procedures for handling such matters established. The complete agenda will be furnished to the CONTRACTOR prior to the meeting date.

The CONTRACTOR should be prepared to discuss all of the items listed below:

- a. Status of CONTRACTOR's insurance and bonds.
- b. CONTRACTOR's tentative schedules.
- c. Transmittal, review, and distribution of CONTRACTOR's Submittals.
- d. Processing applications for payment.
- e. Maintaining record documents.
- f. Critical Work sequencing.
- g. Field decisions, RFI's and Change Orders.
- h. Use of Project site, office and storage areas, security, housekeeping, and OWNER's needs.
- i. Major equipment deliveries and priorities.
- j. CONTRACTOR's assignments for safety and first aid.

- 4. The OWNER will preside at the Pre-Construction Conference and will arrange for keeping and distributing the minutes to all persons in attendance.
- 5. The CONTRACTOR and its Subcontractors should plan on the conference taking no less than one full working day. The first day will cover the items listed in paragraph 3, and the following day(s) will be spent on reviewing the Plans and Specifications, in extensive detail, with the ENGINEER and the OWNER.

B. Progress Meetings

- 1. The CONTRACTOR shall schedule and hold regular on-site progress meetings at least weekly and at other times as requested by the ENGINEER, or as required by progress of the WORK. The CONTRACTOR, ENGINEER, and all Subcontractors active on the site must attend each meeting. CONTRACTOR may at its discretion request attendance by representatives of its Suppliers, Manufacturers, and other Subcontractors.
- 2. The ENGINEER shall preside at the meetings and will arrange for keeping and distributing the minutes. The purpose of the meetings will be to review the progress of the WORK, maintain coordination of efforts, discuss changes in scheduling, and resolve other problems which may develop. During each meeting, the CONTRACTOR is required to present any issues which may impact its WORK, with a view to resolve these issues expeditiously.

- 1.10 DEFINITIONS APPLICABLE TO TECHNICAL SPECIFICATIONS. The following words have the meaning defined in the Technical Portions of the WORK:

Furnish - means to supply and deliver to the site, to unload and unpack ready for assembly, installation, testing, and start-up.

Indicated - is a word used to direct the CONTRACTOR to information contained on the drawings or in the Specifications. Terms such as "shown," "noted," "scheduled," and "specified" also may be used to assist in locating information but no limitation of location is implied or intended.

SECTION 01010 - SUMMARY OF WORK

Install - defines operations at the site including assembly, erection, placing, anchoring, applying, shaping to dimension, finishing, curing, protecting, and cleaning, ready for the OWNER's use.

Installer - a person or firm engaged by the CONTRACTOR or its Subcontract or any Subcontractor for the performance of installation, erection, or application work at the site. Installers must be expert in the operations they are engaged to perform.

Provide - is defined as furnish and install, ready for the intended use.

PART 2 - PRODUCTS (Not Used)

PART 3 - EXECUTION (Not Used)

END OF SECTION

SECTION 01025 - MEASUREMENT AND PAYMENT

PART 1 - GENERAL

1.1 SCOPE

- A. Payment for the various items of the Bid Schedule, as further specified herein, shall include all compensation to be received by the CONTRACTOR for furnishing all tools, equipment, supplies, and manufactured articles, and for all labor, operations, and incidentals appurtenant to the items of WORK being described, as necessary to complete the various items of the WORK all in accordance with the requirements of the Contract Documents, including all appurtenances thereto, and including all costs of PERMITS and cost of compliance with the regulations of public agencies having jurisdiction, including Safety and Health Requirements of the Occupational Safety and Health Administration of the U.S. Department of Labor (OSHA).
- B. No separate payment will be made for any pay item that is not specifically set forth in the Bid Schedule, and all costs therefore shall be included in the prices named in the Bid Schedule for the various appurtenant items of WORK.
- C. In addition to other incidental items of WORK listed elsewhere in the contract, the following items shall also be considered as incidental to other items of WORK under this contract:
 - 1. Removal and replacement of survey monuments and markers disturbed during construction, whether shown on the Plans or not.
 - 2. Re-vegetating areas disturbed during construction.
 - 3. Temporary shoring of trenches or bracing of existing facilities as required for constructing any/all improvements.
 - 4. Erosion and pollution control.
 - 5. Maintenance of all services through the Project area, including water, storm, garbage pickup, mail delivery, other deliveries and emergency vehicles.
 - 6. All traffic control, including flaggers.
 - 7. Minor changes in configuration to fit field conditions
 - 8. Removing existing coating prior to welding
 - 9. Repair of coatings after welding
 - 10. All floats, platforms, scaffolding, access ladders and temporary structures to perform work at the existing structure
 - 11.

1.2 MOBILIZATION (Pay Item No. 1505.1) PRICE BASED ON LUMP SUM

- A. Measurement for payment for Mobilization will be based upon the completion of the entire WORK as a Lump Sum Pay Unit, complete, all in accordance with the requirements of the Contract Documents.
- B. Payment for Mobilization will be made at the amount shown on the Base Bid under Pay Item No. 1505.1, which payment will constitute full compensation for all WORK described in Section 01505 - Mobilization, as shown on the Plans and as directed by the ENGINEER.
- C. Partial payments will be made as the WORK progresses as follows:
 - 1. When 5% of the total original contract amount is earned from other pay items, 50% of the amount bid for Mobilization, or 5% of the original contract amount, whichever is lesser, will be paid.
 - 2. When 10% of the total original contract amount is earned from other pay items,

SECTION 01025 - MEASUREMENT AND PAYMENT

100% of the amount bid for Mobilization, or 10% of the original Contract amount, whichever is lesser, will be paid.

3. Upon completion of all WORK on the Project, payment of any amount bid for Mobilization in excess of 10% of the total original contract amount will be paid.

2.1 DEMOLITION, SALVAGE AND DISPOSAL (Pay Item Nos. 2060.1) PRICE BASED ON LUMP SUM

- A. Measurement for payment for Demolition, Salvage and Disposal will be based upon the completion of the entire WORK as a Lump Sum, Pay Unit, including removal of existing timbers for pile installation and replacement and other items complete, and in accordance with the requirements of the Contract Documents.
- B. Payment for Demolition and Disposal under the Base Bid will be made at the Unit Price named in the Bid Schedule under Pay Item No. 2060.1, which payment will constitute full compensation for all WORK described in Section 02060 - Demolition and Disposal, as shown on the Plans and as directed by the ENGINEER.

2.2 BATTER PILES AND CONNECTIONS (Pay Item No. 2896.6) PRICE BASED ON QUANTITY, EACH

- A. Batter Piles and Connections shall be measured per each, complete in place, including fins and conical pile tip, steel pipe, pile cap plates, stiffener plates, weldments and other appurtenances, complete in place, all in accordance with the requirements of the Contract Documents and as shown on the plans. Batter Piles shall be furnished by the CONTRACTOR in the lengths indicated on the Plans.
- B. Payment for Batter Pile Connections under the Base Bid shall be made at the Unit Price named in the Bid Schedule under Pay Item No. 2896.6, which payment will constitute full compensation for all WORK described in Section 02896 – Steel Pipe Piles, as shown on the Plans and as directed by the ENGINEER.

2.1 GROUTING (Pay Item No. 3303.1) PRICE BASED ON LUMP SUM

- B. Measurement for payment for Grouting will be based upon the completion of the entire WORK as a Lump Sum, Pay Unit, complete, in accordance with the requirements of the Contract Documents, as shown on the Plans, and as directed by the ENGINEER.
- C. Payment for Grouting will be made at the Unit Price named in the Base Bid under Pay Item No. 3303, which payment will constitute full compensation for all WORK described in Section 3303 – Grouting, as shown on the Plans, and as directed by the ENGINEER.

2.2 STEEL BEAMS FOR DECK STRENGTHENING (Pay Item No. 05120.1) PRICE BASED ON QUANTITY, LINEAR FEET

- A. Measurement for payment for Steel beams for Deck Strengthening under the Base Bid will be per linear feet including fabricating steel and erecting steel beams, complete, in-place, all in accordance with the requirements of the Contract Documents..

SECTION 01025 - MEASUREMENT AND PAYMENT

- C. Payment for Steel Beams for Deck Strengthening under the Base Bid shall be made at the Unit Price named in the Bid under Pay Item No. 05120.1, which payment shall constitute full compensation for all WORK described in Section 05120 – Structural Steel Strengthening, as shown on the plans and as directed by the ENGINEER.

2.3 STEEL BEAM CONNECTIONS (Pay Item No. 05120.2) PRICE BASED ON QUANTITY, EACH

- A. Measurement for payment for Steel Beam Connections under the Base Bid will be per each, including removal of existing coatings, welding of steel connection plates to the existing structure, repairing coatings, installing and tightening bolts, complete, in place all in accordance with the requirements of the Contract Documents.
- B. Payment for Steel Beam Connections under the Base Bid shall be made at the Unit Price named in the Bid under Pay Item No. 05120.2, which payment shall constitute full compensation for all WORK described in Section 05120– Structural Steel, as shown on the plans and as directed by the ENGINEER.

PART 2 - PRODUCTS (Not Used)

PART 3 - EXECUTION (Not Used)

END OF SECTION

SECTION 01045 - CUTTING AND PATCHING

PART 1 - GENERAL

1.1 DEFINITION

- A. "Cutting and Patching" is defined to include the cutting and patching of nominally completed and previously existing concrete, steel, wood and miscellaneous metal structures; piping and pavement, in order to accommodate the coordination of WORK, or the installation of other facilities or structures or to uncover other facilities and structures for access or inspection, or to obtain samples for testing, or for similar purposes.

1.2 REQUIREMENTS OF STRUCTURAL WORK

- A. Structural WORK shall not be cut and patched in a manner resulting in a reduction of load-carrying capacity or load/deflection ratio.
- B. Prior to cutting and patching the following categories of WORK, the CONTRACTOR shall obtain the ENGINEER's approval to proceed with:
 - 1. Structural steel
 - 2. Miscellaneous structural metals, including equipment supports, stair systems and similar categories of work
 - 3. Structural concrete
 - 4. Foundation construction including piles
 - 5. Timber and primary wood framing and bullrails
 - 6. Bearing and retaining walls
 - 7. Structural decking
 - 8. Pressurized piping, vessels and equipment
 - 9. Asphalt pavement, concrete or asphalt curb/gutter, and concrete sidewalk
 - 10. Concrete or timber floats

1.3 OPERATIONAL AND SAFETY LIMITATIONS

- A. The CONTRACTOR shall not cut and patch operational elements and safety-related components in a manner resulting in a reduction of capacities to perform in the manner intended or resulting in decreased operational life, increased maintenance, or decreased safety.
- B. Prior to cutting and patching the following categories of WORK, the CONTRACTOR shall obtain the ENGINEER's approval to proceed with:
 - 1. Sheeting, shoring and cross bracing
 - 2. Operating systems and equipment
 - 3. Water, moisture, vapor, air, smoke barriers, membranes and flashing
 - 4. Noise and vibration control elements and systems
 - 5. Control, communication, conveying and electrical wiring systems

1.4 VISUAL REQUIREMENTS

- A. The CONTRACTOR shall not cut and patch WORK which is exposed on the exterior or exposed in occupied spaces, in a manner resulting in a reduction of visual qualities or resulting in substantial evidence of the cut and patch work, both as judged solely by the

SECTION 01045 - CUTTING AND PATCHING

ENGINEER. The CONTRACTOR shall remove and replace work judged by the ENGINEER to have been cut and patched in a visually unsatisfactory manner.

1.5 APPROVALS

- A. Where prior approval of cutting and patching is required, the CONTRACTOR shall submit the request and obtain approval prior to performing the WORK. The request should include a description of why cutting and patching cannot reasonably be avoided; how it will be performed; how structural elements (if any) will be reinforced; products to be used; firms and tradespeople who will perform the WORK; approximate dates of the WORK; and anticipated results in terms of structural, operational, and visual variations from the original WORK.

PART 2 - PRODUCTS

2.1 MATERIALS USED IN CUTTING AND PATCHING

- A. Except as otherwise indicated, the CONTRACTOR shall provide materials for cutting and patching which will result in equal-or-better WORK than the WORK being cut and patched, in terms of performance characteristics and including visual effects where applicable. The CONTRACTOR shall use material identical with the original materials where feasible.
- B. Materials shall comply with the requirements of the Technical Specifications wherever applicable.

PART 3 - EXECUTION

3.1 PREPARATION

- A. The CONTRACTOR shall provide adequate temporary support for WORK to be cut to prevent failure.
- B. The CONTRACTOR shall provide adequate protection of other WORK during cutting and patching.

3.2 INSTALLATION

- A. The CONTRACTOR shall employ skilled tradespeople to perform cutting and patching. Except as otherwise indicated, the CONTRACTOR shall proceed with cutting and patching at the earliest feasible time and perform the WORK promptly.
- B. The CONTRACTOR shall use methods least likely to damage WORK to be retained and WORK adjoining.
 - 1. In general, where physical cutting action is required, the CONTRACTOR shall cut WORK with sawing and grinding tools, not with hammering and chopping tools. Openings through concrete work shall be core-drilled and all final edges shall be ground smooth to prevent wear.
 - 2. Comply with the requirements of Technical Specifications wherever applicable.

SECTION 01045 - CUTTING AND PATCHING

3. Comply with the requirements of applicable sections of Division 2 where cutting and patching requires excavation and backfill.
- C. The CONTRACTOR shall patch with seams which are as invisible as possible and comply with specified tolerances for the WORK.
- D. The CONTRACTOR shall restore exposed seams of patched area; and, where necessary, extend finish restoration onto retained WORK adjoining, in a manner which will eliminate evidence of patching.

END OF SECTION

SECTION 01070 - ACRONYMS OF INSTITUTIONS

PART 1 - GENERAL

1.1 GENERAL

- A. Wherever in these Specifications references are made to the standards, specifications, or other published data of the various international, national, regional, or local organizations, such organizations may be referred to by their acronym or abbreviation only. As a guide to the user of these Specifications, the following acronyms which may appear in these Specifications shall have the meanings indicated herein.

1.2 ACRONYMS

AAMA	Architectural Aluminum Manufacturer's Association
AAR	Association of American Railroads
AASHTO	American Association of State Highway and Transportation Officials
AATCC	American Association of Textile Chemists and Colorists
ACI	American Concrete Institute
AFBMA	Anti-Friction Bearing Manufacturer's Association, Inc.
AGA	American Gas Association
AGMA	American Gear Manufacturer's Association
AHAM	Association of Home Appliance Manufacturers
AI	The Asphalt Institute
AIA	American Institute of Architects
AISC	American Institute of Steel Construction
AISI	American Iron and Steel Institute
AITC	American Institute of Timber Construction
AMCA	Air Moving and Conditioning Association
ANS	American Nuclear Society
ANSI	American National Standards Institute, Inc.
APA	American Plywood Association
API	American Petroleum Institute
APWA	American Public Works Association
ASA	Acoustical Society of America
ASAE	American Society of Agricultural Engineers
ASCE	American Society of Civil Engineers
ASHRAE	American Society of Heating, Refrigerating, and Air Conditioning Engineers
ASLE	American Society of Lubricating Engineers
ASME	American Society of Mechanical Engineers
ASQC	American Society for Quality Control
ASSE	American Society of Sanitary Engineers
ASTM	American Society for Testing and Materials
ATM	Alaska Test Methods
AWPA	American Wood Preservers Association
AWPI	American Wood Preservers Institute
AWS	American Welding Society
AWWA	American Water Works Association
BBC	Basic Building Code, Building Officials and Code Administrators International
BHMA	Builders Hardware Manufacturer's Association
CBM	Certified Ballast Manufacturers

SECTION 01070 - ACRONYMS OF INSTITUTIONS

CEMA	Conveyors Equipment Manufacturer's Association
CGA	Compressed Gas Association
CLFMI	Chain Link Fence Manufacturer's Institute
CMA	Concrete Masonry Association
CRSI	Concrete Reinforcing Steel Institute
DCDMA	Diamond Core Drill Manufacturer's Association
EIA	Electronic Industries Association
ETL	Electrical Test Laboratories
FPL	Forest Products Laboratory
HI	Hydronics Institute
ICBO	International Conference of Building Officials
IEEE	Institute of Electrical and Electronics Engineers
IES	Illuminating Engineering Society
IME	Institute of Makers of Explosives
IOS	International Organization for Standardization
IP	Institute of Petroleum (London)
IPC	Institute of Printed Circuits
IPCEA	Insulated Power Cable Engineers Association
ISA	Instrument Society of America
ITE	Institute of Traffic Engineers
MBMA	Metal Building Manufacturer's Association
MPTA	Mechanical Power Transmission Association
MTI	Marine Testing Institute
NAAMM	National Association of Architectural Metal Manufacturer's
NACE	National Association of Corrosion Engineers
NBS	National Bureau of Standards
NCCLS	National Committee for Clinical Laboratory Standards
NEC	National Electrical Code
NEMA	National Electrical Manufacturer's Association
NFPA	National Fire Protection Association
NFPA	National Forest Products Association
NLGI	National Lubricating Grease Institute
NMA	National Microfilm Association
NWMA	National Woodwork Manufacturers Association
OSHA	Occupational Safety and Health Administration
PCA	Portland Cement Association
RIS	Redwood Inspection Service
RVIA	Recreational Vehicle Industry Association
RWMA	Resistance Welder Manufacturer's Association
SAE	Society of Automotive Engineers
SAMA	Scientific Apparatus Makers Association
SMA	Screen Manufacturers Association
SMACCNA	Sheet Metal and Air Conditioning Contractors National Association
SPIB	Southern Pine Inspection Bureau
SPR	Simplified Practice Recommendation
SSA	Swedish Standards Association
SSBC	Southern Standard Building Code, Southern Building Code Congress
SSPC	Steel Structures Painting Council
SSPWC	Standard Specifications for Public Works Construction
TAPPI	Technical Association of the Pulp and Paper Industry
TFI	The Fertilizer Institute

SECTION 01070 - ACRONYMS OF INSTITUTIONS

UBC	Uniform Building Code
UL	Underwriters Laboratories, Inc.
WCLIB	West Coast Lumber Inspection Bureau
WCRSI	Western Concrete Reinforcing Steel Institute
WIC	Woodwork Institute of California
WRI	Wire Reinforcement Institute, Inc.
WWPA	Western Wood Products Association

PART 2 - PRODUCTS (Not Used)

PART 3 - EXECUTION (Not Used)

END OF SECTION

SECTION 01090 - REFERENCE STANDARDS

PART 1 - GENERAL

1.1 GENERAL

- A. Titles of Sections and Paragraphs: Captions accompanying specification sections and paragraphs are for convenience of reference only, and do not form a part of the Specifications.
- B. Applicable Publications: Whenever in these Specifications references are made to published specifications, codes, standards, or other requirements, it shall be understood that wherever no date is specified, only the latest specifications, standards, or requirements of the respective issuing agencies which have been published as of the date that the WORK is advertised for bids, shall apply; except to the extent that said standards or requirements may be in conflict with applicable laws, ordinances, or governing codes. No requirements set forth herein or shown on the Drawings shall be waived because of any provision of, or omission from, said standards or requirements.
- C. Specialists, Assignments: In certain instances, specification text requires (or implies) that specific work is to be assigned to specialists or expert entities, who must be engaged for the performance of that work. Such assignments shall be recognized as special requirements over which the CONTRACTOR has no choice or option. These requirements shall not be interpreted so as to conflict with the enforcement of building codes and similar regulations governing the WORK; also they are not intended to interfere with local union jurisdiction settlements and similar conventions. Such assignments are intended to establish which party or entity involved in a specific unit of work is recognized as "expert" for the indicated construction processes or operations. Nevertheless, the final responsibility for fulfillment of the entire set of contract requirements remains with the CONTRACTOR.

1.2 REFERENCE SPECIFICATIONS, CODES, AND STANDARDS

- A. Without limiting the generality of other requirements of the Specifications, all WORK specified herein shall conform to or exceed the requirements of applicable codes and the applicable requirements of the following documents.
- B. References herein to "Building Code" or "Uniform Building Code" shall mean Uniform Building Code of the International Conference of Building Officials (ICBO).
- C. Similarly, references to "Mechanical Code" or "Uniform Mechanical Code," "Plumbing Code" or "Uniform Plumbing Code," "Fire Code" or "Uniform Fire Code," shall mean Uniform Mechanical Code, Uniform Plumbing Code and Uniform Fire Code of the International Conference of the Building Officials (ICBO). "Electric Code" or "National Electric Code (NEC)" shall mean the National Electric Code of the National Fire Protection Association (NFPA). The latest edition of the codes as approved by the Municipal Code and used by the local agency as of the date that the WORK is advertised for bids, as adopted by the agency having jurisdiction, shall apply to the WORK herein, including all addenda, modifications, amendments, or other lawful changes thereto.
- D. In case of conflict between codes, reference standards, drawings and the other Contract Documents, the most stringent requirements shall govern. All conflicts shall be brought

SECTION 01090 - REFERENCE STANDARDS

to the attention of the ENGINEER for clarification and directions prior to ordering or providing any materials or furnishing labor. The CONTRACTOR shall bid for the most stringent requirements.

- E. The CONTRACTOR shall construct the WORK specified herein in accordance with the requirements of the Contract Documents and the referenced portions of those referenced codes, standards, and specifications listed herein.
- F. Applicable Standard Specifications: References in Contract Sections 02801 -Asphalt Concrete Pavement to Standard Specifications shall mean the Alaska Department of Transportation and Public Facilities "Standard Specifications for Highway Construction - 1998" and any supplements or amendments thereto.
- G. References herein to "OSHA Regulations for Construction" shall mean Title 29, Part 1926, Construction Safety and Health Regulations, Code of Federal Regulations (OSHA), including all changes and amendments thereto.
- H. References herein to "OSHA Standards" shall mean Title 29, Part 1910, Occupational Safety and Health Standards, Code of Federal Regulations (OSHA), including all changes and amendments thereto.

PART 2 - PRODUCTS (Not Used)

PART 3 - EXECUTION (Not Used)

END OF SECTION

SECTION 01300 - CONTRACTOR SUBMITTALS

PART 1 - GENERAL

1.1 GENERAL

- A. Whenever submittals are required hereunder, all such submittals by the CONTRACTOR shall be submitted to the ENGINEER.
- B. Within 14 days after the date of commencement as stated in the Notice of Award/Notice to Proceed, the CONTRACTOR shall submit the following items to the ENGINEER for review:
 - 1. A preliminary schedule of Shop Drawing, Sample and proposed Substitutes or "Or-Equal" submittals.
 - 2. A list of all permits and licenses the CONTRACTOR shall obtain indicating the agency required to grant the permit and the expected date of submittal for the permit and the required date for receipt of the permit.
 - 3. A complete progress schedule for all phases of the project, based on Critical Path Scheduling.
 - 4. All required Material Safety Data Sheets.
 - 5. A staging and traffic maintenance plan, as required.
 - 6. A plan for temporary erosion control and pollution control, as required.
 - 7. A letter designating the CONTRACTOR's Superintendent, defining that person's responsibility and authority, and providing a specimen of his signature.
 - 8. A letter designating the CONTRACTOR's safety representative and the person's responsibility and authority.
 - 9. Schedule of Values.

1.2 SHOP DRAWING SUBMITTAL

- A. Wherever called for in the Contract Documents, or where required by the ENGINEER, the CONTRACTOR shall furnish to the ENGINEER, for review, electronic submittals in PDF format or 4 copies of each shop drawing submittal, one of which will be returned to the Contractor. The term "Shop Drawings" as used herein shall be understood to include detail design calculations, shop drawings, fabrication and installation drawings, erection drawings, lists, graphs, operating instructions, catalog sheets, data sheets, and similar items.
- B. All Shop Drawing Submittals shall be accompanied by the ENGINEER's standard submittal transmittal form. The form may be obtained in quantity from the ENGINEER. Any submittal not accompanied by such a form, or where all applicable items on the form are not completed, will be returned for resubmittal.
- C. Normally, a separate transmittal form shall be used for each specific item or class of material or equipment for which a submittal is required. Transmittal of a submittal of various items using a single transmittal form will be permitted only when the items taken together constitute a manufacturer's "package" or are so functionally related that expediency indicates review of the group or package as a whole. A multiple-page submittal shall be collated into sets, and each set shall be stapled or bound, as appropriate, prior to transmittal to the ENGINEER.

SECTION 01300 - CONTRACTOR SUBMITTALS

- D. Except as otherwise provided herein, the ENGINEER will return prints of each submittal to the CONTRACTOR with its comments noted thereon, within 21 calendar days following their receipt by the ENGINEER. It is considered reasonable that the CONTRACTOR shall make a complete and acceptable submittal to the ENGINEER by the second submission of a submittal item. The OWNER reserves the right to withhold monies due to the CONTRACTOR to cover additional costs of the ENGINEER review beyond the second submittal. The ENGINEER's maximum review period for each submittal including all re-submittals will be 21 days per submission. In other words, for a submittal that requires two re-submittals before it is complete, the maximum review period for that submittal could be 63 days.
- E. If a submittal is returned to the CONTRACTOR marked "NO EXCEPTIONS TAKEN," formal revision and resubmission of said submittal will not be required.
- F. If a submittal is returned to the CONTRACTOR marked "MAKE CORRECTIONS NOTED," formal revision and resubmission of said submittal is not required.
- G. If one copy of the submittal is returned to the CONTRACTOR marked "AMEND-RESUBMIT," the CONTRACTOR shall revise said submittal and shall resubmit the required number of copies of said revised submittal to the ENGINEER.
- H. If one copy of the submittal is returned to the CONTRACTOR marked "REJECTED-RESUBMIT," the CONTRACTOR shall revise said submittal and shall resubmit the required number of copies of said revised submittal to the ENGINEER.
- I. Fabrication of an item may be commenced only after the ENGINEER has reviewed the pertinent submittal and returned copies to the CONTRACTOR marked either "NO EXCEPTIONS TAKEN" or "MAKE CORRECTIONS NOTED." Corrections indicated on submittal shall be considered as changes necessary to meet the requirements of the Contract Documents and shall not be taken as the basis for changes to the Contract requirements. Only a change order can alter the contract price, time, or requirements.
- J. All CONTRACTOR shop drawing submittals shall be carefully reviewed by an authorized representative of the CONTRACTOR, prior to submission to the ENGINEER. Each submittal shall be dated, signed, and certified by the CONTRACTOR, as being correct and in strict conformance with the Contract Documents. In the case of shop drawings, each sheet shall be so dated, signed, and certified. No consideration for review by the ENGINEER of any CONTRACTOR submittal will be made for any items which have not been so certified by the CONTRACTOR. All non-certified submittals will be returned to the CONTRACTOR without action taken by the ENGINEER, and any delays caused thereby shall be the total responsibility of the CONTRACTOR.
- K. The ENGINEER's review of CONTRACTOR shop drawing submittals shall not relieve the CONTRACTOR of the entire responsibility for the correctness of details and dimensions. The CONTRACTOR shall assume all responsibility and risk for any misfits due to any errors in CONTRACTOR submittals. The CONTRACTOR shall be responsible for the dimensions and the design of adequate connections and details.

SECTION 01300 - CONTRACTOR SUBMITTALS

1.3 SAMPLES SUBMITTAL

- A. Whenever in the Specifications samples are required, the CONTRACTOR shall submit not less than 3 samples of each item or material to the ENGINEER for acceptance at no additional cost to the OWNER.
- B. Samples, as required herein, shall be submitted for acceptance a minimum of 21 days prior to ordering such material for delivery to the job site, and shall be submitted in an orderly sequence so that dependent materials or equipment can be assembled and reviewed without causing delays in the WORK.
- C. All samples shall be individually and indelibly labeled or tagged, indicating thereon all specified physical characteristics and Supplier's names for identification and submitted to the ENGINEER for acceptance. Upon receiving acceptance of the ENGINEER, one set of the samples will be stamped and dated by the ENGINEER and returned to the CONTRACTOR, and one set of samples will be retained by the ENGINEER, and one set of samples shall remain at the job site until completion of the WORK.
- D. Unless clearly stated otherwise, it is assumed that all colors and textures of specified items presented in sample submittal are from the manufacturer's standard colors and standard materials, products, or equipment lines. If the samples represent non-standard colors, materials, products or equipment lines, and their selection will require an increase in contract time or price, the CONTRACTOR will clearly indicate this on the transmittal page of the submittal.

1.4 TECHNICAL MANUAL SUBMITTAL (O&M MANUAL)

- A. Using the outline provided in the Equipment Maintenance Summary Sheet (copy of which may be obtained from the ENGINEER), the CONTRACTOR shall include (5) five copies of the technical manuals for the project including the following:
 - 1. All final Submittals and Shop Drawings, as listed in the submittal register.
- B. The CONTRACTOR shall furnish to the ENGINEER 5 identical sets of technical manuals. Each set shall consist of one or more volumes, each of which shall be bound in a standard size, 3-ring, loose-leaf vinyl plastic hard cover binder suitable for bookshelf storage. Binder ring size shall not exceed 2.5 inches. A table of contents shall be provided which indicates all equipment in the technical manuals.
- C. All technical manuals shall be submitted in final form to the ENGINEER not later than the 75 percent of construction completion date. All discrepancies found by the ENGINEER in the technical manuals shall be corrected by the CONTRACTOR within 30 days from the date of written notification by the ENGINEER.
- D. Incomplete or unacceptable technical manuals at the 75 percent construction completion point shall constitute sufficient justification to withhold payment for work completed beyond that period in accordance with Paragraph "Technical Manual Submittal" of Section 01700, "Project Closeout."

SECTION 01300 - CONTRACTOR SUBMITTALS

1.5 SPARE PARTS LIST SUBMITTAL

- A. The CONTRACTOR shall furnish to the ENGINEER 5 identical sets of spare parts information for all mechanical, electrical, and instrumentation equipment. The spare parts list shall include the current list price of each spare part. The spare parts list shall be limited to those spare parts which each manufacturer recommends be maintained by the OWNER in inventory at the plant site. Each manufacturer or supplier shall indicate the name, address, and telephone number of its nearest outlet of spare parts to facilitate the OWNER in ordering. The CONTRACTOR shall cross-reference all spare parts lists to the equipment numbers designated in the Contract Documents. The spare parts lists shall be bound in standard size, 3-ring, loose leaf, vinyl plastic hard cover binders suitable for bookshelf storage. Binder ring size shall not exceed 2.5 inches.

1.6 RECORD DRAWINGS SUBMITTALS

- A. The CONTRACTOR shall keep and maintain, at the job site, one record set of Drawings. On these, it shall mark all Project conditions, locations, configurations, and any other changes or deviations which may vary from the details represented on the original contract Drawings, including buried or concealed construction and utility features which are revealed during the course of construction. Special attention shall be given to recording the horizontal and vertical location of all buried utilities that differ from the locations indicated, or which were not indicated on the contract Drawings. Said record drawings shall be supplemented by any detailed sketches as necessary or directed to indicate, fully, the WORK as actually constructed. These master record drawings, of the CONTRACTOR's representation of as-built conditions, including all revisions made necessary by addenda, change orders, and the like shall be maintained up-to-date during the progress of the WORK.
- B. In the case of those drawings which depict the detail requirement for equipment to be assembled and wired in the factory, such as motor control centers and the like, the record drawings shall be updated by indicating those portions which are superseded by Change Order Drawings or final Shop Drawings, and by including appropriate reference information describing the Change Orders by number and the Shop Drawings by manufacturer, drawing, and revision numbers.
- C. Record Drawings shall be accessible to the ENGINEER at all times during the construction period and shall be delivered to the ENGINEER on the 20th working day of every third month after the month in which the Notice to Proceed is given as well as upon completion of the WORK.
- D. Final payment will not be acted upon until the CONTRACTOR-prepared record drawings have been delivered to the ENGINEER.

1.7 PROGRESS SCHEDULES

- A. The progress schedule shall be in Bar Chart format and shall utilize a Critical Path Method (CPM). The Contractor shall submit monthly updates of the progress schedule to the Engineer for approval.

SECTION 01300 - CONTRACTOR SUBMITTALS

- B. The progress schedule shall show the order in which the CONTRACTOR proposes to carry out the WORK and the contemplated date on which the CONTRACTOR and their subcontractors will start and finish each of the salient features of the work, including any scheduled periods of shutdown. The schedule shall also indicate any anticipated periods of multiple-shift work.
- C. Upon substantial changes to the CONTRACTOR's progress schedule of work or upon request of the ENGINEER, the CONTRACTOR shall submit a revised progress schedule(s) in the form required. Such revised schedule(s) shall conform with the Contract Time and take into account delays which may have been encountered in the performance of the WORK, identifying any delays or time required to implement changed conditions. In submitting a revised schedule, the CONTRACTOR shall state specifically the reason for the revision and the adjustments made in his schedule or methods of operation to ensure the completion of all the WORK within the Contract Time.

1.8 PROPOSED SUBSTITUTES OR "OR-EQUAL" ITEM SUBMITTAL

- A. Whenever materials or equipment are specified or described in the Contract Documents by using the name of a proprietary item or the name of a particular Supplier, the naming of the item is intended to establish the type, function, and quality required. If the name is followed by the words "or-equal" indicating that a substitution is permitted, materials or equipment of other suppliers may be accepted by the ENGINEER if sufficient information is submitted by the CONTRACTOR to allow the ENGINEER to determine that the material or equipment proposed is equivalent or equal to that named, subject to the following requirements:
 - 1. The burden of proof as to the type, function, and quality of any such substitute material or equipment shall be upon the CONTRACTOR.
 - 2. The ENGINEER will be the sole judge as to the type, function, and quality of any such substitute material or equipment and the ENGINEER's decision shall be final.
 - 3. The ENGINEER may require the CONTRACTOR, to furnish at the CONTRACTOR's expense, additional data about the proposed substitute.
 - 4. The OWNER may require the CONTRACTOR to furnish at the CONTRACTOR's expense a special performance guarantee or other surety with respect to any substitute.
 - 5. Acceptance by the ENGINEER of a substitute item proposed by the CONTRACTOR shall not relieve the CONTRACTOR of the responsibility for full compliance with the Contract documents and for adequacy of the substitute item.
 - 6. The CONTRACTOR shall be responsible for resultant changes and all additional costs which the accepted substitution requires in the CONTRACTOR's work, the work of its subcontractors and of other contractors, and shall effect such changes without cost to the OWNER. This shall include the cost for redesign and claims of other contractor affected by the resulting change.
- B. The procedure for review by the ENGINEER will include the following:

SECTION 01300 - CONTRACTOR SUBMITTALS

1. If the CONTRACTOR wishes to furnish or use a substitute item of material or equipment, the CONTRACTOR shall make written application to the ENGINEER on the "Substitution Request Form" for acceptance thereof.
 2. Unless otherwise provided by law or authorized in writing by the ENGINEER, the "Substitution Request Form(s)" shall be submitted within the 21-day period after Notice of Award.
 3. Wherever a proposed substitute material or equipment has not been submitted within said 21-day period, or wherever the submission of a proposed substitute material or equipment has been judged to be unacceptable by the ENGINEER, the CONTRACTOR shall provide material or equipment named in the Contract Documents.
 4. The CONTRACTOR shall certify that the proposed substitute will perform adequately the functions and achieve the results called for by the general design, be similar and of equal substance to that specified, and be suited to the same use as that specified.
 5. The ENGINEER will be allowed a reasonable time within which to evaluate each proposed substitute. In no case will this reasonable time period be less than 30 days.
 6. As applicable, no shop drawing submittals will be made for a substitute item nor will any substitute item be ordered, installed, or utilized without the ENGINEER's prior written acceptance of the CONTRACTOR's "Substitution Request Form" which will be evidenced by a Change Order.
 7. The ENGINEER will record the time required by the ENGINEER in evaluating substitutions proposed by the CONTRACTOR and in making changes in the Contract Documents occasioned thereby. Whether or not the ENGINEER accepts a proposed substitute, the CONTRACTOR shall reimburse the OWNER for the charges of the ENGINEER for evaluating each proposed substitute.
- C. The CONTRACTOR's application using the "Substitution Request Forms" shall contain the following statements and/or information which shall be considered by the ENGINEER in evaluating the proposed substitution:
1. The evaluation and acceptance of the proposed substitute will not prejudice the CONTRACTOR's achievement of substantial completion on time.
 2. Whether or not acceptance of the substitute for use in the WORK will require a change in any of the Contract Documents to adopt the design to the proposed substitute.
 3. Whether or not incorporation or use of the substitute in connection with the WORK is subject to payment of any license fee or royalty.
 4. All variations of the proposed substitute for that specified will be identified.
 5. Available maintenance, repair, and replacement service and its estimated cost will be indicated.
 6. Itemized estimate of all costs that will result directly or indirectly from acceptance of such substitute, including cost of redesign and claims of other contractors affected by the resulting change.

1.9 MATERIAL CERTIFICATON SUBMITTAL

- A. The ENGINEER may permit the use, prior to sampling, inspection and testing, of certain materials or assemblies when accompanied by manufacturer's material certifications

SECTION 01300 - CONTRACTOR SUBMITTALS

stating that such materials or assemblies fully comply with the requirements of the Contract. The certification shall be signed by the manufacturer, and will specifically reference the material's compliance with the AASHTO, ASTM and/or CBJ Standards specified in the applicable Contract Documents.

- B. Material Certifications shall be submitted to the engineer prior to incorporating the item into the WORK.
- C. Materials or assemblies used on the basis of material certifications may be sampled, inspected and/or tested at any time, and if found not in conformity with these Specifications, will be subject to rejection whether in place or not.

PART 2 - PRODUCTS (not used)

PART 3 - EXECUTION (not used)

(SUBSTITUTION REQUEST FORM – next page)

SECTION 01300 - CONTRACTOR SUBMITTALS

**City and Borough of Wrangell
SUBSTITUTION REQUEST FORM**

TO: _____ Project: _____
Contract No. _____
OWNER: _____

SPECIFIED ITEM:

Section	Page	Paragraph	Description
---------	------	-----------	-------------

The undersigned requests consideration of the following:

PROPOSED SUBSTITUTION: _____

Attached data includes product description, specifications, drawings, photographs, performance and test data adequate for evaluation of the request. Applicable portions of the data are clearly identified.

The undersigned states that the following paragraphs, unless modified on attachments are correct:

1. The proposed substitution does not affect dimensions shown on Drawings and will not require a change in any of the Contract Documents.
2. The undersigned will pay for changes to the design, including engineering design, detailing, and construction costs caused by the requested substitution which is estimated to be \$ _____.
3. The proposed substitution will have no adverse affect on other contractors, the construction schedule (specifically the date of substantial completion), or specified warranty requirements.
4. Maintenance and service parts will be locally available for the proposed substitution.
5. The incorporation or use of the substitute in connection with the WORK is not subject to payment of any license fee or royalty.

The undersigned further states that the function, appearance, and quality of the Proposed Substitution are equivalent or superior to the Specified item.

Submitted by CONTRACTOR: _____ Reviewed by ARCHITECT/ENGINEER _____
Signature _____ Accepted Accepted as Noted
Firm: _____ Not Accepted Received Too Late
By: _____ Date: _____
Title: _____ Telephone: _____
Date: _____
Attachments: _____

END OF SECTION

SECTION 01400 - QUALITY CONTROL

PART 1 - GENERAL

1.1 DEFINITION

- A. Specific quality control requirements for the WORK are indicated throughout the Contract Documents. The requirements of this Section are primarily related to performance of the WORK beyond furnishing of manufactured products. The term "Quality Control" includes inspection, sampling and testing, and associated requirements.

1.2 INSPECTION AT PLACE OF MANUFACTURE

- A. Unless otherwise indicated, all products, materials, and equipment shall be subject to inspection by the ENGINEER at the place of manufacture.
- B. The presence of the ENGINEER at the place of manufacturer, however, shall not relieve the CONTRACTOR of the responsibility for furnishing products, materials, and equipment which comply with all requirements of the Contract Documents. Compliance is a duty of the CONTRACTOR, and said duty shall not be avoided by any act or omission on the part of the ENGINEER.

1.3 SAMPLING AND TESTING

- A. Unless otherwise indicated, all sampling and testing shall be in accordance with the methods prescribed in the current standards of the ASTM, ATM, and AASHTO as applicable to the class and nature of the article or materials considered; however, the OWNER reserves the right to use any generally-accepted system of sampling and testing which, in the opinion of the ENGINEER will insure the OWNER that the quality of the workmanship is in full accord with the Contract Documents.
- B. Any waiver by the OWNER of any specific testing or other quality assurance measures, whether or not such waiver is accompanied by a guarantee of substantial performance as a relief from the specified testing or other quality assurance requirements as originally specified, and whether or not such guarantee is accompanied by a performance bond to assure execution of any necessary corrective or remedial WORK, shall not be construed as a waiver of any requirements of the Contract Documents.
- C. Notwithstanding the existence of such waiver, the ENGINEER reserves the right to make independent investigations and tests, and failure of any portion of the WORK to meet any of the requirements of the Contract Documents, shall be reasonable cause for the ENGINEER to require the removal or correction and reconstruction of any such work in accordance with the General Conditions.

1.4 INSPECTION AND TESTING LABORATORY SERVICE

- A. Inspection and testing laboratory service shall comply with the following:
 - 1. OWNER will appoint, employ, and pay for services of an independent firm to perform inspection and testing or will perform inspection and testing itself unless

SECTION 01400 - QUALITY CONTROL

specific quality control testing is required by the CONTRACTOR under these specifications.

2. The ENGINEER will perform inspections as specified in individual specification sections, unless specified otherwise.
3. Reports will be submitted by the independent firm to the ENGINEER in duplicate, indicating observations and results of tests and indicating compliance or non-compliance with Contract Documents.
4. The CONTRACTOR shall cooperate with the ENGINEER or independent firm and furnish samples of materials, design mix, equipment, tools, storage and assistance as requested.
5. The CONTRACTOR shall notify ENGINEER 24 hours prior to the expected time for operations requiring inspection and laboratory testing services.
6. Retesting required because of non-conformance to specified requirements shall be performed by the same independent firm on instructions by the ENGINEER. The CONTRACTOR shall bear all costs from such retesting at no additional cost to the OWNER.
7. For samples and tests required for CONTRACTOR'S use, the CONTRACTOR shall make arrangements with an independent firm for payment and scheduling of testing. The cost of sampling and testing for the CONTRACTOR'S use shall be included in the Contract Price.

PART 2 - PRODUCTS (Not Used)

PART 3 - EXECUTION

3.1 INSTALLATION

- A. **Inspection:** The CONTRACTOR shall inspect materials or equipment upon the arrival on the job site and immediately prior to installation, and reject damaged and defective items.
- B. **Measurements:** The CONTRACTOR shall verify measurements and dimensions of the WORK, as an integral step of starting each installation.
- C. **Manufacturer's Instructions:** Where installations include manufactured products, the CONTRACTOR shall comply with manufacturer's applicable instructions and recommendations for installation, to whatever extent these are more explicit or more stringent than applicable requirements indicated in Contract Documents.

END OF SECTION

SECTION 01505 - MOBILIZATION

PART 1 - GENERAL

1.1 GENERAL

- A. Mobilization shall include obtaining permits; moving onto the site of all plant and equipment; furnishing and erecting plants, temporary buildings, and other construction facilities; and implementing security requirements; all as required for the proper performance and completion of the WORK. Mobilization shall include the following principal items:
1. Moving on to the site of all CONTRACTOR's plant and equipment required for operations.
 2. Providing all on-site communication facilities, including radios and cellular phones.
 3. Obtaining all required permits other than those provided in the Contract Documents.
 4. Having all OSHA required notices and establishment of safety programs.
 5. Having the CONTRACTOR's superintendent at the job site full time.
 6. Submitting initial submittals.

1.2 PAYMENT FOR MOBILIZATION

- A. The CONTRACTOR's attention is directed to the condition that no payment for Mobilization, or any part thereof, will be approved for payment under the contract until all Mobilization items listed above have been completed as specified.
- B. As soon as practicable after receipt of the Notice to Proceed, the CONTRACTOR shall submit a breakdown to the ENGINEER for approval, which shall show the estimated value of each major component of Mobilization. When approved by the ENGINEER, the breakdown will be the basis for initial progress payments in which Mobilization is included.

PART 2 – PRODUCTS (Not Used)

PART 3 – EXECUTION (Not Used)

END OF SECTION

SECTION 01520 - SECURITY

PART 1 - GENERAL

1.1 SECURITY PROGRAM

A. The CONTRACTOR shall:

1. Protect WORK, existing premises and OWNER's operations from theft, vandalism, and unauthorized entry.
2. Coordinate security with OWNER's operations at job mobilization.
3. Maintain program throughout construction period until OWNER's occupancy.

1.2 ENTRY CONTROL

A. The CONTRACTOR shall:

1. Control entry of persons and vehicles onto Project construction site and existing facilities.
2. Allow entry on the construction site only to authorized persons with proper identification.
3. Coordinate access of OWNER's personnel to site in coordination with CONTRACTOR's security forces.

B. OWNER will control entrance of persons and vehicles related to OWNER's operations.

PART 2 - PRODUCTS (Not Used)

PART 3 - EXECUTION (Not Used)

END OF SECTION

SECTION 01530 - PROTECTION AND RESTORATION OF EXISTING FACILITIES

PART 1 - GENERAL

1.1 GENERAL

- A. The CONTRACTOR shall protect all existing utilities and improvements not designated for removal and shall restore damaged or temporarily relocated utilities and improvements to a condition equal to or better than they were prior to such damage or temporary relocation, all in accordance with requirements of the Contract Documents.
- B. All utility locates shall be the responsibility of the CONTRACTOR. CALL DIAL BEFORE YOU DIG AT 874-3904 for water and sanitary sewer locates and 907-874-3602 for electrical underground utilities within the WORK limits prior to any work.
- C. The CONTRACTOR shall verify the exact locations and depths of all utilities and the CONTRACTOR shall make exploratory excavations of all utilities that may interfere with the WORK. All such exploratory excavations shall be performed as soon as practicable after award of the contract and, in any event, a sufficient time in advance of construction to avoid possible delays to the CONTRACTOR's WORK. Any utility or service in conflict with the WORK will be reburied by the CONTRACTOR prior beginning the WORK to avoid damage.
- D. The number of exploratory excavations required shall be that number which is sufficient to determine the alignment and grade of the utility.

1.2 RIGHTS-OF-WAY

- A. The CONTRACTOR shall not do any work that would affect any oil, gas, sewer, or water pipeline; any telephone, cable television, telegraph, or electric transmission line; any fence; or any other structure, nor shall the CONTRACTOR enter upon the rights-of-way involved until notified by the ENGINEER that the OWNER has secured authority therefor from the proper party. After authority has been obtained, the CONTRACTOR shall give said party due notice of its intention to begin work, if required by said party, and shall remove, shore, support or otherwise protect such pipeline, transmission line, ditch, fence, or structure or replace the same. When two or more contracts are being executed at one time on the same or adjacent land in such manner that work on one contract may interfere with that on another, the OWNER shall determine the sequence and order of the WORK. When the territory of one contract is the necessary or convenient means of access for the execution of another contract, such privilege of access or any other reasonable privilege may be granted by the OWNER to the CONTRACTOR so desiring, to the extent, amount, in the manner, and at the times permitted.
- B. No such decision as to the method or time of conducting the WORK or the use of territory shall be made the basis of any claim for delay or damage, except as provided for temporary suspension of the WORK in Article 15 of the General Conditions of the contract.

1.3 PROTECTION OF SURVEY MONUMENTS, STREET AND/OR ROADWAY MARKERS

- A. The CONTRACTOR shall not destroy, remove, or otherwise disturb any existing survey markers or other existing street or roadway markers without proper authorization. No pavement breaking or excavation shall be started until all survey or other permanent marker points that will be disturbed by the construction operations have been properly referenced. All survey monuments, markers or points disturbed by the CONTRACTOR shall be accurately re-established, at the CONTRACTOR's expense unless provided for

SECTION 01530 - PROTECTION AND RESTORATION OF EXISTING FACILITIES

elsewhere in the contract, after all street or roadway resurfacing has been completed. Re-establishment of all survey monuments shall be by a Registered Alaskan Land Surveyor.

1.4 RESTORATION OF PAVEMENT

- A. General: All paved areas, including asphalt concrete berms, cut or damaged during construction shall be replaced with similar materials and of equal thickness to match the existing adjacent undisturbed areas, except where specific resurfacing requirements have been called for in the Contract Documents or in the requirements of the agency issuing the permit. All temporary and permanent pavement shall conform to the requirements of the affected pavement owner. All pavements which are subject to partial removal shall be neatly saw cut in straight lines.
- B. Temporary Resurfacing: Wherever required by the public authorities having jurisdiction, the CONTRACTOR shall place temporary surfacing promptly after backfilling and shall maintain such surfacing for the period of time fixed by said authorities before proceeding with the final restoration of improvements.
- C. Permanent Resurfacing: In order to obtain a satisfactory junction with adjacent surfaces, the CONTRACTOR shall saw cut back and trim the edge so as to provide a clean, sound, vertical joint before permanent replacement of an excavated or damaged portion of pavement. Damaged edges of pavement along excavations and elsewhere shall be trimmed back by saw cutting in straight lines. All pavement restoration and other facilities restoration shall be constructed to finish grades compatible with adjacent undisturbed pavement.
- D. Restoration of Sidewalks or Private Driveways: Wherever sidewalks or private roads have been removed for purposes of construction, the CONTRACTOR shall place suitable temporary sidewalks or roadways promptly after backfilling and shall maintain them in satisfactory condition for the period of time fixed by the authorities having jurisdiction over the affected portions before proceeding with the final restoration or, if no such period of times is so fixed, the CONTRACTOR shall maintain said temporary sidewalks or roadways until the final restoration thereof has been made.

1.5 EXISTING UTILITIES AND IMPROVEMENTS

- A. General: The CONTRACTOR shall protect all Underground Utilities and other improvements which may be impaired during construction operations. It shall be the CONTRACTOR's responsibility to ascertain the actual location of all existing utilities and other improvements that will be encountered in its construction operations, and to see that such utilities or other improvements are adequately protected from damage due to such operations. The CONTRACTOR shall take all possible precautions for the protection of unforeseen utility lines to provide for uninterrupted service and to provide such special protection as may be necessary.
- B. Utilities to be Moved: In case it shall be necessary to move the property of any public utility or franchise holder, such utility company or franchise holder will, upon request of the CONTRACTOR, be notified by the OWNER to move such property within a specified reasonable time. When utility lines that are to be removed are encountered within the area of operations, the CONTRACTOR shall notify the ENGINEER a sufficient time in advance for the necessary measures to be taken to prevent interruption of service.
- C. Where the proper completion of the WORK requires the temporary or permanent removal and/or relocation of an existing utility or other improvement which is indicated, the

SECTION 01530 - PROTECTION AND RESTORATION OF EXISTING FACILITIES

CONTRACTOR shall remove and, without unnecessary delay, temporarily replace or relocate such utility or improvement in a manner satisfactory to the ENGINEER and the owner of the facility. In all cases of such temporary removal or relocation, restoration to former location shall be accomplished by the CONTRACTOR in a manner that will restore or replace the utility or improvement as nearly as possible to its former locations and to as good or better condition than found prior to removal.

- D. **OWNER's Right of Access:** The right is reserved to the OWNER and to the owners of public utilities and franchises to enter at any time upon any public street, alley, right-of-way, or easement for the purpose of making changes in their property made necessary by the WORK of this contract.
- E. **Underground Utilities Indicated:** Existing utility lines that are indicated or the locations of which are made known to the CONTRACTOR prior to excavation and that are to be retained, and all utility lines that are constructed during excavation operations shall be protected from damage during excavation and backfilling and, if damaged, shall be immediately repaired or replaced by the CONTRACTOR.
- F. **Underground Utilities Not Indicated:** In the event that the CONTRACTOR damages any existing utility lines that are not indicated or the locations of which are not made known to the CONTRACTOR prior to excavation, a written report thereof shall be made immediately to the ENGINEER. If directed by the ENGINEER, repairs shall be made by the CONTRACTOR under the provisions for changes and extra work contained in Articles 10, 11, and 12 of the General Conditions.
- G. **All costs of locating, repairing damage not due to failure of the CONTRACTOR to exercise reasonable care, and removing or relocating such utility facilities not shown in the Contract Documents with reasonable accuracy, and for equipment on the project which was actually working on that portion of the WORK which was interrupted or idled by removal or relocation of such utility facilities, and which was necessarily idled during such work will be paid for as extra work in accordance with the provisions of Articles 10, 11, and 12 of the General Conditions.**
- H. **Approval of Repairs:** All repairs to a damaged utility or improvement are subject to inspection and approval by an authorized representative of the utility or improvement owner before being concealed by backfill or other work.
- I. **Maintaining in Service:** All oil and gasoline pipelines, power, and telephone, cable television or the communication cable ducts, gas and water mains, irrigation lines, sewer lines, storm drain lines, poles, and overhead power and communication wires and cables encountered along the line of the WORK shall remain continuously in service during all the operations under the Contract, unless other arrangements satisfactory to the ENGINEER are made with the owner of said pipelines, duct, main, irrigation line, sewer, storm drain, pole, or wire or cable. The CONTRACTOR shall be responsible for and shall repair all damage due to its operations, and the provisions of this Section shall not be abated even in the event such damage occurs after backfilling or is not discovered until after completion of the backfilling.

1.6 TREES WITHIN STREET RIGHTS-OF-WAY AND PROJECT LIMITS

- A. **General:** The CONTRACTOR shall exercise all necessary precautions so as not to damage or destroy any trees or shrubs, including those lying within street rights-of-way and project limits, and shall not trim or remove any trees unless such trees have been approved for trimming or removal by the jurisdictional agency or OWNER. All existing trees and shrubs which are damaged during construction shall be trimmed or replaced by

SECTION 01530 - PROTECTION AND RESTORATION OF EXISTING FACILITIES

the CONTRACTOR or a certified tree company under permit from the jurisdictional agency and/or the OWNER. Tree trimming and replacement shall be accomplished in accordance with the following paragraphs.

- B. Trimming: Symmetry of the tree shall be preserved; no stubs or splits or torn branches left; clean cuts shall be made close to the trunk or large branch. Spikes shall not be used for climbing live trees. All cuts over 1-1/2 inches in diameter shall be coated with an asphaltic emulsion material.
- C. Replacement: The CONTRACTOR shall immediately notify the jurisdictional agency and/or the OWNER if any tree is damaged by the CONTRACTOR's operations. If, in the opinion of said agency or the OWNER, the damage is such that replacement is necessary, the CONTRACTOR shall replace the tree at its own expense. The tree shall be of a like size and variety as the tree damaged, or, the CONTRACTOR shall pay to the owner of said tree a compensatory payment acceptable to the tree owner, subject to the approval of the jurisdictional agency or OWNER.

1.7 PROTECTION OF EXISTING STRUCTURES

- A. Compaction Equipment and Operations: The CONTRACTOR shall restrict its compaction operations as necessary to assure no damage occurs to adjacent buildings. This may require the use of smaller compaction equipment than is usually employed for trench backfill and roadway embankment compaction operations when in the vicinity of buildings sensitive to vibrating or other impact-type activities. It shall be the CONTRACTOR's responsibility to determine in which areas of the project the compaction operations must be restricted, to avoid damage to existing buildings. The CONTRACTOR is advised that some structures on the project, especially those founded on steep or unstable ground, and are especially sensitive to vibrations caused by heavy construction equipment. The foregoing restrictions on the size of, and magnitude of impact energy exerted by, compaction equipment will in no way relieve the CONTRACTOR from the compaction requirements as specified in other Sections of the contract.
- B. The CONTRACTOR shall notify all affected businesses and other residents in advance of any operations that will cause vibrations that may damage belongings within the buildings. All property damage caused by the CONTRACTOR's operations shall be repaired or replaced at CONTRACTOR's expense.

PART 2 PRODUCTS – (Not Used)

PART 3 EXECUTION - (Not used)

END OF SECTION

SECTION 01550 - SITE ACCESS AND STORAGE

PART 1 - GENERAL

- 1.1 HIGHWAY LIMITATIONS. The CONTRACTOR shall make its own investigation of the condition of available public and private roads and of clearances, restrictions, bridge load limits, and other limitations affecting transportation and ingress and egress to the site of the WORK. It shall be the CONTRACTOR's responsibility to construct and maintain any haul roads required for its construction operations.
- 1.2 TEMPORARY CROSSINGS
- A. General: Continuous, unobstructed, safe, and adequate pedestrian access shall be provided to the Boat Yard, fire hydrants, commercial and industrial establishments, private residences, churches, schools, parking lots, service stations, motels, fire and police stations, and hospitals. Safe and adequate public transportation stops and pedestrian crossings at intervals not exceeding 200 feet shall be provided. The CONTRACTOR shall cooperate with parties involved in the delivery of mail and removal of trash and garbage so as to maintain existing schedules for such services. Vehicular access to residential driveways shall be maintained to the property line except when necessary construction precludes such access for reasonable periods of time, as approved by the ENGINEER.
- B. Temporary Bridges: Wherever necessary, the CONTRACTOR shall provide suitable temporary bridges or steel plates over unfilled excavations, except in such cases as the CONTRACTOR shall secure the written consent of the individuals or authorities concerned to omit such temporary bridges or steel plates, which written consent shall be delivered to the ENGINEER prior to excavation. All such bridges or steel plates shall be maintained in service until access is provided across the backfilled excavation. Temporary bridges or steel plates for street and highway crossing shall conform to the requirements of the authority having jurisdiction in each case, and the CONTRACTOR shall adopt designs furnished by said authority for such bridges or steel plates, or shall submit designs to said authority for approval, as may be required.
- 1.3 MAINTENANCE OF TRAFFIC
- A. General: Unless otherwise provided, the roadway undergoing improvements shall be kept open to all traffic by the CONTRACTOR. Nothing herein shall be construed to entitle the CONTRACTOR to the exclusive use of any public street, alleyway, or parking area during the performance of the WORK hereunder, and it shall so conduct its operations as not to interfere unnecessarily with the authorized work of utility companies or other agencies in such streets, alleyways, or parking areas. The CONTRACTOR shall provide unimpeded access through the Project limits for emergency vehicles and make every effort to provide minimum delay to United States Postal Service vehicles and garbage collection vehicles.
- B. The CONTRACTOR shall submit three (3) copies of a traffic control plan to the ENGINEER for approval a minimum of two (2) weeks prior to construction. The ENGINEER reserves the right to observe these traffic control plans in use and to make any changes as field conditions warrant. Any changes shall supersede these plans and be done solely at the CONTRACTOR's expense.
- C. No street shall be closed to the public without first obtaining permission of the ENGINEER and proper governmental authority. Where so provided on the plans or otherwise approved by the ENGINEER, the CONTRACTOR may by-pass traffic over a detour route. When no longer required, the detour shall be removed and the approached obliterated.

SECTION 01550 - SITE ACCESS AND STORAGE

- D. Where excavation is being performed in primary streets or highways, one lane in each direction shall be kept open to traffic at all times unless otherwise indicated. Toe boards shall be provided to retain excavated material if required by the ENGINEER or the agency having jurisdiction over the street or highway. Fire hydrants on or adjacent to the WORK shall be kept accessible to fire-fighting equipment at all times. Temporary provisions shall be made by the CONTRACTOR to assure the use of sidewalks and the proper functioning of all gutters, storm drain inlets, and other drainage facilities.
- E. The CONTRACTOR's equipment shall stop at all points of intersection with the traveling public unless satisfactory traffic control measures, approved in writing by the ENGINEER, are installed and maintained at CONTRACTOR's expense.
- F. When the CONTRACTOR is required to maintain traffic through grading, roadway excavation and embankment areas, the construction shall be conducted in such a manner as to provide a reasonably smooth and even surface satisfactory for use by public traffic at all times. The surface of the roadbed shall be properly crowned for drainage. In advance of other grading operations, sufficient fill shall be placed at culverts and bridges to permit traffic to cross unimpeded. Part width construction techniques shall be employed when the traffic is routed through roadway cuts or over embankments under construction. The material shall be excavated or placed in layers and the construction activities shall be alternated from one side to the other, with traffic routed over the side opposite the one under construction.
- G. During the removal and laying of culvert pipe, a maximum time of one hour of road closure may be permitted, providing the removal and laying of the culvert pipe cannot be completed for one-half width of the roadway and provided that a detour cannot be constructed around the culvert being laid. Closure shall be scheduled so as not to delay buses and peak hour traffic. The CONTRACTOR shall post, at the site of the closure within view of the waiting public traffic, the time the closure started and the time the road will again be open to traffic. The CONTRACTOR shall notify the Fire and Police Departments of such closures prior to commencement of work.
- H. At intervals of 48 hours and 24 hours prior to start up of construction operations, and at weekly intervals during the construction period, the CONTRACTOR shall advertise on the local newspaper, Airport, and at City Hall the precise location, time of commencement, and proposed completion date of the WORK scheduled for the following week which will require detouring or otherwise effect public traffic. Detours shall be described in sufficient detail to efficiently inform the traveling public of the modified traffic pattern. The cost of these advertisements shall be considered incidental to other contract bid items. The CONTRACTOR will notify the property owners 24 hours prior to commencement of WORK.
- I. When, in the opinion of the ENGINEER, conditions are such that the safety and/or convenience of the traveling public is adversely affected, the CONTRACTOR will be immediately notified in writing. The notice will state the defect(s) and the corrective action(s) required. In the event that the CONTRACTOR neglects to take immediate corrective action, the ENGINEER may suspend all work on the project until satisfactory corrective action is performed. In the event the CONTRACTOR does not take corrective action within 24 hours, the ENGINEER may order such work as deemed necessary for public convince and safety accomplished by outside forces. The cost of this work shall be deducted from any monies due or that may become due under the terms or the contract.

SECTION 01550 - SITE ACCESS AND STORAGE

- J. The CONTRACTOR shall bear all expense of maintaining the traffic over the section of road undergoing improvement, including dust control and snow plowing, and of constructing and maintaining such approaches, crossings, intersections, and other features as may be necessary, without direct compensation, except as provided below:
1. Special Detours. When the proposal contains a bid item for detours, the payment for such item shall cover all cost of constructing and maintaining such detour or detours, including the construction of any and all temporary bridges and accessory features and the removal of the same, and obliteration of the detour road. Right-of-way for temporary highways or bridges will be furnished by the OWNER.
 2. Maintenance of Traffic During Suspension of WORK. The CONTRACTOR shall make passable and shall open to traffic such portions of the Project and temporary roadways as may be agreed upon between the CONTRACTOR and the ENGINEER for the temporary accommodation of necessary traffic during the anticipated period of suspension. If the suspension is seasonal (winter shutdown), thereafter, and until an issuance of an order for the resumption of construction operations, the maintenance of the temporary route of line of travel agreed upon will be the responsibility of the OWNER. Prior to the OWNER accepting the Project for winter shutdown, the CONTRACTOR shall do all work necessary to provide a roadway surface and subgrade that will not require the OWNER to perform additional maintenance work during the shutdown period, except for purpose of snow removal. If the WORK is suspended due to unfavorable weather, failure of the CONTRACTOR to correct conditions unsafe for the workers or the general public, failure to carry out provisions of the contract, or for failure to carry out orders of the ENGINEER, all costs for maintenance of traffic during the suspended period shall be borne by the CONTRACTOR. When WORK is resumed, the CONTRACTOR shall replace or renew any WORK or materials lost or damaged because of temporary use of the project; shall remove, to the extent directed by the ENGINEER, any WORK or materials used in the temporary maintenance; and shall complete the Project as though its prosecution had been continuous and without interference.
- K. Traffic Control: All locations requiring redirection or stopping of the traveling public shall be properly signed and/or flagged by the CONTRACTOR. For the protection of traffic in public or private streets and ways, the CONTRACTOR shall provide, flaggers and provide, place, and maintain all necessary barricades, traffic cones, warning signs, lights, and other safety devices in accordance with the requirements of the "Manual of Uniform Traffic Control Devices, Part VI - Traffic Controls for Street and Highway Construction and Maintenance Operations," (MUTCD) published by U.S. Department of Transportation, Federal Highway Administration (ANSI D6.1) with the current State of Alaska supplements.
- L. The CONTRACTOR shall take all necessary precautions for the protection of the WORK and the safety of the public. All barricades and obstructions shall be illuminated at night, and all lights shall be kept burning from sunset until sunrise. The CONTRACTOR shall station such guards or flaggers and shall conform to such special safety regulations relating to traffic control as may be required by the public authorities within their respective jurisdictions. All signs, signals, and barricades shall conform to the requirements of Subpart G, Part 1926, of the OSHA Safety and Health Standards for Construction.

SECTION 01550 - SITE ACCESS AND STORAGE

- M. Special pedestrian detours are often necessary in areas adjacent to new construction or demolition of existing structures. The ENGINEER shall determine when walkways are required. Plans for walkways must be approved by the ENGINEER.
- N. The CONTRACTOR shall remove traffic control devices when no longer needed, repair all damage caused by installation of the devices, and shall remove post settings and backfill the resulting holes to match grade.
- O. Temporary Street Closure: If closure of any street is required during construction, the CONTRACTOR shall apply in writing to the Borough Manager, CBW Public Works, DOT and any other jurisdictional agency at least 30 days in advance of the required closure and again at 48 hours. A Detour and Traffic Control Plan shall accompany the application.
- P. The CONTRACTOR shall notify the Police and Fire Departments and any other affected agency of all planned street closures. Notification shall consist of giving the time of commencement and proposed date of completion of work and names of street, schedule of operations, and routes of detours. Such notification shall be given at least 48 hours before such closure is to take effect.
- Q. Temporary Driveway Closure: The CONTRACTOR shall maintain access to all residential, commercial and street approaches. Any temporary closures shall require prior approval by the ENGINEER. The CONTRACTOR shall notify the owner or occupant (if not owner-occupied) of the closure of the driveways to be closed more than one (1) eight-hour work day at least three (3) working days prior to the closure. The CONTRACTOR shall minimize the inconvenience and minimize the time period that the driveways will be closed. The CONTRACTOR shall fully explain to the owner/occupant how long the work will take and when closure is to start.
- R. On-Site Cellular Phones: The CONTRACTOR shall maintain one active cellular phone at the project site at all times with the phone number provided to the Wrangell Fire, Police and Engineering Departments. The cellular phone shall be carried by the person in charge of the field operations. The CONTRACTOR shall provide and allow the use of the CONTRACTOR's radio frequency to facilitate communication between the CONTRACTOR and the ENGINEER.

1.4 CONTRACTOR'S WORK AND STORAGE AREA

- A. The CONTRACTOR shall make its own arrangements for any necessary off-site storage or shop areas necessary for the proper execution of the WORK.
- B. Should the CONTRACTOR find it necessary to use any additional land for its camp or for other purposes during the construction of the WORK, it shall provide for the use of such lands at its own expense.
- C. The CONTRACTOR shall construct and use a separate storage area for hazardous materials used in constructing the WORK.
 - 1. For the purpose of this paragraph, hazardous materials to be stored in the separate area are all products labeled with any of the following terms: **Warning, Caution, Poisonous, Toxic, Flammable, Corrosive, Reactive, or Explosive.** In addition, whether or not so labeled, the following materials shall be stored in the separate area: diesel fuel, gasoline, new and used motor oil, hydraulic fluid, cement, paints and paint thinners, two-part epoxy coatings, sealants, asphaltic

SECTION 01550 - SITE ACCESS AND STORAGE

products, glues, solvents, wood preservatives, sand blast materials, and spill absorbent.

2. The CONTRACTOR shall develop and submit to the ENGINEER a plan for storing and disposing of the materials above.
3. The CONTRACTOR shall obtain and submit to the ENGINEER a single EPA number for wastes generated at the site.
4. The separate storage area shall meet all the requirements of all authorities having jurisdiction over the storage of hazardous materials.
5. The separate storage area shall be inspected by the ENGINEER prior to construction of the area, upon completion of construction of the area, and upon cleanup and removal of the area.
6. All hazardous materials which are delivered in containers shall be stored in the original containers until use. Hazardous materials which are delivered in bulk shall be stored in containers which meet the requirements of authorities having jurisdiction.

1.5 PARKING

- A. The CONTRACTOR shall direct its employees to park in areas as directed by the ENGINEER.
- B. Traffic and parking areas shall be maintained in a sound condition, free of excavated material, construction equipment, mud, and construction materials. The CONTRACTOR shall repair breaks, potholes, low areas which collect standing water, and other deficiencies.

PART 2 - PRODUCTS (Not Used)

PART 3 - EXECUTION (Not Used)

END OF SECTION

SECTION 01560 - TEMPORARY ENVIRONMENTAL CONTROLS

PART 1 - GENERAL

- 1.1 DUST ABATEMENT. The CONTRACTOR shall furnish all labor, equipment, and means required and shall carry out effective measures wherever and as often as necessary to prevent its operation from producing dust in amounts damaging to property, cultivated vegetation, or domestic animals, or causing a nuisance to persons living in or occupying buildings in the vicinity. The CONTRACTOR shall be responsible for any damage resulting from any dust originating from its operations. The dust abatement measures shall be continued until the CONTRACTOR is relieved of further responsibility by the ENGINEER.
- 1.2 RUBBISH CONTROL. During the progress of the WORK, the CONTRACTOR shall keep the site of the WORK and other areas used by it in a neat and clean condition, and free from any accumulation of rubbish. The CONTRACTOR shall dispose of all rubbish and waste materials of any nature occurring at the WORK site, and shall establish regular intervals of collection and disposal of such materials and waste. The CONTRACTOR shall also keep its haul roads free from dirt, rubbish, and unnecessary obstructions resulting from its operations. Disposal of all rubbish and surplus materials shall be off the site of construction in accordance with local codes and ordinances governing locations and methods of disposal, and in conformance with all applicable safety laws, and to the particular requirements of Part 1926 of the OSHA Safety and Health Standards for Construction.
- 1.3 SANITATION
- A. Toilet Facilities: Fixed or portable chemical toilets shall be provided wherever needed for the use of employees. Toilets at construction job sites shall conform to the requirements of Part 1926 of the OSHA Standards for Construction.
- B. Sanitary and Other Organic Wastes: The CONTRACTOR shall establish a regular daily collection of all sanitary and organic wastes. All wastes and refuse from sanitary facilities provided by the CONTRACTOR or organic material wastes from any other source related to the CONTRACTOR's operations shall be disposed of away from the site in a manner satisfactory to the ENGINEER and in accordance with all laws and regulations pertaining thereto.
- 1.4 CHEMICALS. All chemicals used during project construction or furnished for project operation, whether defoliant, soil sterilant, herbicide, pesticide, disinfectant, polymer, reactant or of other classification, shall show approval of either the U.S. Environmental Protection Agency or the U.S. Department of Agriculture. Use of all such chemicals and disposal of residues shall be in strict accordance with the printed instructions of the manufacturer. In addition, see the requirements set forth in paragraph 6.11 of the General Conditions.
- 1.5 CULTURAL RESOURCES
- A. The CONTRACTOR's attention is directed to the National Historic Preservation Act of 1966 (16 U.S.C. 470) and 36 CFR 800 which provides for the preservation of potential historical architectural, archaeological, or cultural resources (hereinafter called "cultural resources").
- B. The CONTRACTOR shall conform to the applicable requirements of the National Historic Preservation Act of 1966 as it relates to the preservation of cultural resources.

SECTION 01560 - TEMPORARY ENVIRONMENTAL CONTROLS

- C. In the event potential cultural resources are discovered during subsurface excavations at the site of construction, stop work immediately and notify the ENGINEER.

PART 2 - PRODUCTS (Not Used)

PART 3 - EXECUTION (Not Used)

END OF SECTION

SECTION 01570 - EROSION CONTROL

PART 1 - GENERAL

1.1 THE REQUIREMENT

- A. The CONTRACTOR shall provide for erosion control during construction. All sedimentation from on-site drainage shall be caught on-site.
- B. The WORK under this Section includes providing all labor, materials, tools and equipment necessary to construct and maintain erosion control works; including but not limited to, silt fences, settling ponds, hay or straw bale check dams, ditches, etc.

PART 2 - PRODUCTS

- 2.1 MATERIALS. Materials shall be suitable for the intended use and perform effectively to control silt and surface erosion. All materials shall remain the property of the CONTRACTOR.

PART 3 - EXECUTION

3.1 GENERAL

- A. The CONTRACTOR shall install temporary erosion control structures as necessary and/or as directed by the ENGINEER. They shall be maintained in effective operating condition at all times. Settling ponds and silt fences shall be cleaned whenever they have become half-filled with silt or debris, and other items shall be cleaned, repaired, or replaced as necessary.
- B. Temporary erosion control structures shall remain in place until replaced by permanent erosion control WORK, or until the ENGINEER approves their removal.
- C. All temporary erosion control WORK shall be incidental to the other items in the Contract. The CONTRACTOR shall be responsible for all permits required near streams and water bodies and, therefore, shall be responsible for the quality of the run-off water from the Project site and for any fine and penalties resulting from the construction operation.
- D. The CONTRACTOR shall submit an erosion control plan to the ENGINEER, prior to beginning any WORK at the Project site. No WORK at the Project site will be permitted until approval of this plan has been obtained from the governing agency or agencies.

END OF SECTION

SECTION 01600 - MATERIALS AND EQUIPMENT

PART 1 - GENERAL

1.1 GENERAL

- A. The word "Products," as used herein, is defined to include purchased items for incorporation into the WORK, regardless of whether specifically purchased for project or taken from CONTRACTOR's stock of previously purchased products. The word "Materials," is defined as products which must be substantially cut, shaped, worked, mixed, finished, refined, or otherwise fabricated, processed, installed, or applied to form units of work. The word "Equipment" is defined as products with operational parts, regardless of whether motorized or manually operated, and particularly including products with service connections (wiring, piping, and other like items). Definitions in this paragraph are not intended to negate the meaning of other terms used in Contract Documents, including "specialties," "systems," "structure," "finishes," "accessories," "furnishings," special construction," and similar terms, which are self-explanatory and have recognized meanings in the construction industry.
- B. Neither "Products" nor "Materials" nor "Equipment" includes machinery and equipment used for preparation, fabrication, conveying and erection of the WORK.

1.2 QUALITY ASSURANCE

- A. Source Limitations: To the greatest extent possible for each unit of WORK, the CONTRACTOR shall provide products, materials, or equipment of a singular generic kind from a single source.
- B. Compatibility of Options: Where more than one choice is available as options for CONTRACTOR's selection of a product, material, or equipment, the CONTRACTOR shall select an option which is compatible with other products, materials, or equipment already selected. Compatibility is a basic general requirement of product/material selections.

- 1.3 **PRODUCT DELIVERY/STORAGE/HANDLING.** The CONTRACTOR shall deliver, handle, and store products in accordance with manufacturer's written recommendations and by methods and means which will prevent damage, deterioration, and loss including theft. Delivery schedules shall be controlled to minimize long-term storage of products at site and overcrowding of construction spaces. In particular, the CONTRACTOR shall ensure minimum holding or storage times for products recognized to be flammable, hazardous, easily damaged, or sensitive to deterioration, theft, and other sources of loss.

1.4 TRANSPORTATION AND HANDLING

- A. Products shall be transported by methods to avoid product damage and shall be delivered in undamaged condition in manufacturer's unopened containers or packaging.
- B. The CONTRACTOR shall provide equipment and personnel to handle products, materials, and equipment by methods to prevent soiling and damage.
- C. The CONTRACTOR shall provide additional protection during handling to prevent marring and otherwise damaging products, packaging, and surrounding surfaces.

SECTION 01600 - MATERIALS AND EQUIPMENT

1.5 STORAGE AND PROTECTION

- A. Products shall be stored in accordance with manufacturer's written instructions, with seals and labels intact and legible. Sensitive products shall be stored in weather-tight climate controlled enclosures and temperature and humidity ranges shall be maintained within tolerances required by manufacturer's written instructions.
- B. For exterior storage of fabricated products, they shall be placed on sloped supports above ground. Products subject to deterioration shall be covered with impervious sheet covering; ventilation shall be provided to avoid condensation.
- C. Loose granular materials shall be stored on solid surfaces in a well-drained area and shall be prevented from mixing with foreign matter.
- D. Storage shall be arranged in a manner to provide access for maintenance and inspection. The CONTRACTOR shall periodically inspect to assure products are undamaged and are maintained under required conditions.

1.6 MAINTENANCE OF STORAGE

- A. Stored products shall be periodically inspected on a scheduled basis. The CONTRACTOR shall maintain a log of inspections and shall make said log available to the ENGINEER on request.
- B. The CONTRACTOR shall verify that storage facilities comply with manufacturer's product storage requirements.
- C. The CONTRACTOR shall verify that manufacturer-required environmental conditions are maintained continually.
- D. The CONTRACTOR shall verify that surfaces of products exposed to the elements are not adversely affected and that any weathering of finishes does not occur.
- E. For mechanical and electrical equipment, the CONTRACTOR shall provide a copy of the manufacturer's service instructions with each item and the exterior of the package shall contain notice that instructions are included.
- F. Products shall be serviced on a regularly scheduled basis, and a log of services shall be maintained and submitted as a record document prior to acceptance by the OWNER in accordance with the Contract Documents.

PART 2 - PRODUCTS (Not Used)

PART 3 - EXECUTION (Not Used)

END OF SECTION

SECTION 01700 - PROJECT CLOSE-OUT

PART 1 – GENERAL

- 1.1 FINAL CLEAN-UP. The CONTRACTOR shall promptly remove from the vicinity of the completed work, all rubbish, unused materials, concrete forms, construction equipment, and temporary structures and facilities used during construction. Final acceptance of the WORK by the OWNER will be withheld until the CONTRACTOR has satisfactorily complied with the foregoing requirements for final clean-up of the project site.
- 1.2 CLOSEOUT TIMETABLE. The CONTRACTOR shall establish dates for equipment testing, acceptance periods, and on-site instructional periods (as required under the Contract). Such dates shall be established not less than one week prior to beginning any of the foregoing items, to allow the OWNER, the ENGINEER, and their authorized representatives sufficient time to schedule attendance at such activities.
- 1.3 FINAL SUBMITTALS. The CONTRACTOR, prior to requesting final payment, shall obtain and submit the following items to the ENGINEER for transmittal to the OWNER:
 1. Written guarantees, where required.
 2. Maintenance stock items; spare parts, special tools, where required.
 3. Completed redline record drawings.
 4. Certificates of inspection and acceptance by governing agencies having jurisdiction.
 5. Releases from all parties who are entitled to claims against the subject Project, property, or improvement pursuant to the provisions of law.
 6. Completed Certificate of Compliance and Release for all contractors involved in the WORK. Submit the original signed document to Project Manager.
 7. A tax clearance from both the Department of Labor and the Department of Revenue are required.
 8. Technical Manual (O&M Manual)
 9. DOL's Notice of Completion of Public Works.
- 1.4 MAINTENANCE AND GUARANTEE
 - A. The CONTRACTOR shall comply with the maintenance and guarantee requirements contained in Article 13 of the General Conditions.
 - B. Replacement of earth fill or backfill, where it has settled below the required finish elevations, shall be considered as a part of such required repair work, and any repair or resurfacing constructed by the CONTRACTOR which becomes necessary by reason of such settlement shall likewise be considered as a part of such required repair work unless the CONTRACTOR shall have obtained a statement in writing from the affected private owner or public agency releasing the OWNER from further responsibility in connection with such repair or resurfacing.
 - C. The CONTRACTOR shall make all repairs and replacements promptly upon receipt of written order from the OWNER. If the CONTRACTOR fails to make such repairs or replacements promptly, the OWNER reserves the right to do the WORK and the CONTRACTOR and his surety shall be liable to the OWNER for the cost thereof.

SECTION 01700 - PROJECT CLOSE-OUT

- 1.5 BOND. The CONTRACTOR shall provide a bond to guarantee performance of the provisions contained in Paragraph "Maintenance and Guarantee" above, and Article 13 of the General Conditions.

PART 2 - PRODUCTS (Not Used)

PART 3 - EXECUTION (Not Used)

END OF SECTION

SECTION 01704 - FINAL CLEAN-UP AND SITE RESTORATION

PART 1 - GENERAL

- 1.1 DESCRIPTION. The WORK under this Section includes providing all supervision, labor, materials, tools and equipment necessary for final clean-up and restoration of all areas disturbed by construction activities, to a condition equal to, or better than, before construction started. This does not include clean-up or restoration incidental to, or directly provided for by, other construction items.

PART 2 - PRODUCTS

- 2.1 MATERIALS. Any materials required shall conform to the appropriate Section of these Specifications.

PART 3 - EXECUTION

3.1 CONSTRUCTION

- A. The CONTRACTOR shall clean up all sites disturbed during construction of the project. This includes removal of all construction equipment, disposal of all excess materials, disposal of all rubbish and debris, removal of all temporary structures, and grading of the sites so that no standing water is evident.

END OF SECTION

SECTION 02060 – DEMOLITION, SALVAGE AND DISPOSAL

PART 1 - GENERAL

1.1 DESCRIPTION

- A. WORK under this Section shall include all labor, materials, tools and equipment necessary for the excavation, demolition, salvage and/or proper offsite disposal or storage of all items as described herein and as shown on the Plans. The CONTRACTOR shall provide an appropriate offsite disposal site for all items designated to be disposed. Demolition and disposal methods shall meet all local, state and federal regulations.
- B. The Contractor shall visit the site and determine the extent of salvage and off site disposal prior to bid.

PART 2 - PRODUCTS (Not Used)

PART 3 - EXECUTION

3.1 DEMOLITION AND DISPOSAL

- A. Demolition of the structures and items indicated on the plans shall be done in such a manner as to minimize damage to materials being salvaged.
- B. Conduct demolition to minimize interference with adjacent structures and interruption to public services.
- C. Cease operations immediately if adjacent structures appear to be in danger and notify ENGINEER. Do not resume operations until directed by ENGINEER
- D. Demolish and dispose all other incidental and miscellaneous items as required to complete the project.
- E. Construction signs and barricades shall be installed as required to prevent public entry into WORK area.

END OF SECTION

SECTION 02896 - STEEL PIPE PILES

PART 1 - GENERAL

1.1 DESCRIPTION

- A. The WORK in this Section shall include all labor, materials, tools and equipment necessary to furnish and install all piles, pile driving tips, all miscellaneous appurtenances and hardware, and all other related WORK in accordance with the requirements of the Contract Documents and as shown on the Plans.

1.2 REFERENCES

- A. ASTM A252 - Welded and Seamless Steel Pipe Piles
- B. ASTM A139 – Electric-Fusion (Arc)-Welded Steel Pipe
- C. Steel Structures Painting Council (SSPC) - Steel Structures Painting Manual
- D. ASTM A123 - Zinc (Hot Dipped Galvanized) Coatings on Iron and Steel Products
- E. ASTM A780 – Repair of Damaged and Uncoated Areas of Hot-Dip Galvanized Coatings
- E. AWS D1.1 - Structural Welding Code - Steel

1.3 SUBMITTALS

- A. Manufacturer's Mill Certificate: Steel Certification including chemistry, yield strength, and mill numbers.
- B. Shop Drawings for all fabricated items per Section 05120 – Metal Fabrication.
- C. Welding Procedures: All weld metal proposed to be used in the shop or in the field shall be submitted and approved for use prior to construction. The submittal shall contain all required information and the manufacturer's recommendations for the use of the product on this project.
- D. Welder Certificates: Certify welders employed in the WORK with AWS qualifications within the previous 12 months.
- E. Pile Installation Plan: Provide narrative and illustrations to fully describe complete installation plan. The plan shall address, as a minimum, all equipment, labor, temporary pile support and template systems, survey control, sequence and method of installation. The CONTRACTOR shall not mobilize hammers and related equipment prior to receiving written approval, from the ENGINEER, for the Pile Installation Plan.
- F. Manufacturer's information on all pile hammers intended for use, complete with satisfactory data to ensure properly suited for installation of pipe piles.
- G. Galvanizing certificates verifying that coated material conforms to Specifications.

SECTION 02896 - STEEL PIPE PILES

PART 2 - PRODUCTS

2.1 MATERIALS

- A. All steel pipe piles shall be seamless or straight seam pipe conforming to ASTM A252, Grade 3 with Carbon Equivalency not exceed 0.45. Spiral weld pipe may be used provided it conforms to ASTM A139, Grade E with the following modifications:
2. Referenced Documents – Add the following: 2.2 American Welding Standards.
 5. Manufacturing – Add the following:
 - 5.2 All butt welds shall conform to AWS D1.1. Material shall be without coil butt splices.
 - 5.3 All coils for fabrication shall be “pre-slit” prior to forming, unless otherwise approved by the ENGINEER.
 6. Chemical Composition – Add the following:
 - 6.1 In addition, the Carbon element shall be limited to 0.26% maximum as shown in Table 1.
 - 6.2 Steel Carbon Equivalent shall not exceed 0.45% as calculated by AWS D1.1 Appendix XI.
 12. Hydrostatic Test – Delete this item and all references in this section.
 14. Number of Production Specimens – Substitute the following:
 - 14.2 One reduced-section production weld test specimen specified in 19.5 shall be taken from a length of pipe from each lot of 1,000 feet, or fraction thereof, of each size and wall thickness.
 16. Permissible Variation in Weight and Dimension – Add the following:
 - 16.5 Butt Weld Offset – Butt weld offset shall not exceed the limitations of AWS weld procedure, nor a maximum of 10% of the pipe wall thickness, nor 3/32 of an inch.
 19. Finish – Modify as follows:
 - 19.1 Repair by Welding – Delete and replace with the following: Defects in the weld shall be repaired or the piece rejected at the option of the manufacturer. Repairs of this nature shall be made completely removing the defect, cleaning the cavity, and then rewelding.
- B. All steel pipe piles shall be hot-dip galvanized, full length, in accordance with ASTM A123, unless otherwise noted on the Plans.
- C. All steel pipe piles shall be furnished, complete with pile tips, in the lengths indicated on the Plans. Piles shall be delivered full length or field spliced in accordance with approved welding and galvanizing repair procedures.
- D. Miscellaneous steel plates, shapes and fabricated metal assemblies and weldments shall be ASTM A36, hot-dip galvanized per ASTM A123 or A153, and shall conform to the requirements of Section 05120-Metal Fabrication.

PART 3 - EXECUTION

3.1 PREPARATION AND PROTECTION OF COATINGS

SECTION 02896 - STEEL PIPE PILES

- A. The CONTRACTOR shall become familiar with the site conditions prior to bid.
- B. Galvanized coatings damaged due to fabrication, welding, material handling or occurring during installation shall be repaired per Section 05120 – Metal Fabrication.

3.2 INSTALLATION

- A. Observe any work restrictions or conditions listed in the Department of Army permit.
- B. The CONTRACTOR shall submit a plan for pile driving. The plan shall include pile hammer type and driving method for all pile types, as well as manufacturers' recommendations and information on hammer cushion. The CONTRACTOR shall not mobilize hammers and related equipment prior to receiving written approval of the plan. The CONTRACTOR should allow one week for review of the plan by the ENGINEER. All driving methods shall meet the requirements of the PERMITS issued for this project.
- C. Piles shall be driven full length to the minimum required capacities and embedment to bedrock as indicated on the Plans. Acceptance of a driven pile and determination of pile refusal shall be made solely by the ENGINEER. Any hammer that causes damage to the piles during driving operations shall be substituted with an acceptable, alternate hammer at no additional expense to the OWNER. Impact hammers shall be supplied with new cap block cushions, which shall be changed at the manufacturer's recommended cycle. A pile hammer with a minimum rated energy of approximately 40,000ft-lb shall be used. The use of vibratory hammers shall not be allowed.
- D. Piles shall be installed within 0.5% of specified vertical alignment and within 2 inch of specified location at cutoff. Batter piles with a two foot vertical to one foot horizontal slope shall be placed so their slope varies between 5.875 inches and 6.375 inches horizontal to one foot vertical. Batter piles shall be within 2 inches of location at cutoff. Misaligned or mislocated piles shall be extracted by the CONTRACTOR and shall be reinstalled at no additional cost to the OWNER. The CONTRACTOR shall have suitable equipment on site to extract piles that do not meet the location tolerances specified.
- E. All pile installations shall be conducted with the ENGINEER present. The CONTRACTOR shall assist the ENGINEER in monitoring the pile driving. The CONTRACTOR shall mark each pile with one-foot increments, with every five-foot increment numbered. The marks shall be visible and readable from all sides of the pile.
- F. All steel pipe pile cutoffs greater than five feet in length shall become the property of the OWNER. The CONTRACTOR shall remove the pipe from the project site and shall neatly stack the pipe, as approved by the OWNER, at a location within five miles of the site.

3.3 CONTINGENCY SPLICES

- A. The WORK under this paragraph is contingent and includes providing all labor, materials, tools, and equipment necessary to perform pile splicing that is imperative due to unforeseen site conditions. This section does not include pile splices that make up the pile lengths shown in the pile schedule. This contingency item is only for pile lengths

SECTION 02896 - STEEL PIPE PILES

that are longer than shown in the pile schedule on the Plans. All WORK for contingency splices shall be performed in accordance with the requirements of the Contract Documents and as indicated on the Plans.

END OF SECTION

SECTION 03303 – GROUTING

PART 1 - GENERAL

1.1 DESCRIPTION

- A. The WORK under this Section shall include all labor, materials, tools and equipment necessary for construction of the cast-in-place concrete paving and all other hardware and related Work, in accordance with the requirements of the Contract Documents and as shown on the Plans.

1.2 REFERENCES

- A. ASTM (American Society of Testing Materials) Specifications
- B. ACI (American Concrete Institute) Code
- C. ASTM C150 – Portland Cement
- D. ASTM C33 – Concrete Aggregates
- E. ACI 347 – Recommended Practice for Concrete Formwork

1.3 SUBMITTALS

- A. Grout Mix Design.
- B. Grout Product Information

1.4 QUALITY ASSURANCE

- A. Acquire grout from the same source for all Work.

PART 2 - PRODUCTS

2.1 MATERIALS

- A. Grout shall be a Portland cement, non metallic, non-shrink grout, suitable for exterior application and shall conform to the following requirements:

28-day compressive strength:	7,500 psi
Maximum expansion in 3 days	0.05%
Maximum expansion in 14 days	0.09%
Maximum expansion in 28 days	0.10%
Conforms to ASTM C-1107 Grade A, B and C	

- B. Water used in mix shall be potable

SECTION 03303 – GROUTING

2.4 FORMWORK

- A. Forms shall be designed and constructed to be removed without injuring the grout. They shall be free of bulge and warp, and constructed so the finished grout will be of the form and dimensions shown on the Plans, and true to line and grade.

PART 3 – EXECUTION

3.1 INSTALLATION

- A. Prepare base to receive grout by thoroughly cleaning all contact surfaces. Roughen concrete surface with chipping hammer, bushing tool, sand blasting or other methods to ensure bond. Clean metal to be free of oil and other contaminants. Ensure surfaces are at a temperature between 45 degrees F and 90 degrees F before grouting and during curing. During cold weather comply with manufacturer's instructions. Wet and saturate concrete 4 hours prior to receiving grout and remove all surface water just prior to placement.
- B. Mixing: Mix in accordance with proportions specified in grout manufacturer's instructions, submitted by the CONTRACTOR, and approved by the ENGINEER. Grout shall be mixed in a batch mixer of acceptable size and type which will ensure a uniform distribution of materials throughout the mix so as to produce a homogeneous mix, uniform in color. All grout shall be placed within (1) hour after water is first added to the batch. The mixer shall be cleaned at frequent intervals while in use.
- C. Mix grout to dry-pack or flowable consistency. Add the minimum amount of water to achieve the desired consistency.
- D. Placing Grout:
 - 1. Notify ENGINEER a minimum of 24 hours prior to commencement of operations.
 - 2. Place grout in accordance manufacturer's instructions. If flowable, seal forms to prevent grout loss and on the placement side provide an angle in the form high enough to assist in the grouting and to maintain head pressure on the grout.
 - 3. Remove water and debris from space to be poured.
 - 4. Do not use grout which becomes non-plastic and unworkable and does not meet the required quality control limits, or has been contaminated by foreign materials.
 - 5. Remove rejected grout from the site.
- D. Equipment:
 - 1. Provide adequate number of mechanically maintained equipment, including spare units, to ensure completion of grout mixing, pumping and placement, as required, without delay or stopping.
- E. Finishing:

SECTION 03303 – GROUTING

1. All finished or formed surfaces shall accurately conform to the shape, alignment, grades and sections as shown of the Plans.
- F. Curing and Protection:
1. Cure and protect grout in accordance with manufacturer's instructions.
 2. Immediately after placement, protect grout from premature drying, cold temperatures and physical damage.
 3. Wood forms allowed to remain in place during the curing period shall be keep moist at all times.
- G. Defective grout consists of grout not conforming to mix design, required lines, details, dimensions, tolerances or other specified requirements. Repair or replacement of defective grout shall be determined by the ENGINEER. Defective grout shall be repaired and/or replaced at no additional cost to the OWNER.

END OF SECTION

SECTION 05120 – STRUCTURAL STEEL

PART 1 - GENERAL

1.1 DESCRIPTION.

- A. The WORK in this Section shall include all labor, materials, tools and equipment necessary to fabricate and install all structural steel and aluminum items in accordance with the requirements of the Contract Documents and as shown on the Plans.

1.2 REFERENCES

- A. AISC (American Institute of Steel Construction) Code of Standard Practice - Manual of Steel Construction - Allowable Stress Design (ASD).
- B. ASTM (American Society of Testing Materials) Specifications
- C. ASTM A36/A36M - Structural Steel Plate.
- D. ASTM A572/Gr.50- High-Strength Low-Alloy Columbium-Vanadium Structural Steel
- E. ASTM A6 – General Requirements for Rolled Steel Plates, Shapes, Sheet piling, and Bars for Structural Use.
- F. ASTM A123 - Zinc (Hot Dipped Galvanized) Coatings on Iron and Steel Products.
- G. ASTM A153 - Zinc Coating (Hot Dip) on Iron and Steel Hardware.
- H. ASTM A325 - High Strength Bolts for Structural Steel Joints.
- I. ASTM A563 – Caron and Alloy Steel Nuts
- J. ASTM A780 – Practice for Repair of Damage and Uncoated of Hot-Dip Galvanized Coatings
- K. ASTM A992 – Steel for Structural Shapes Used In Building Framing.
- L. ASTM F436 – Hardened Steel Washers
- M. AWS D1.1 - Structural Welding Code - Steel.

1.3 SUBMITTALS

- A. Fabrication Shop Drawings of all fabricated steel items prior to fabrication.
 - 1. Indicate welds by standard AWS symbols, distinguishing between shop and field welds, and show size, length and type of each weld.
 - 2. Include details of cuts, connections, splices, camber, holes, and other pertinent data.
 - 3. Indicate type, size and length of bolts, distinguishing between shop and field bolts. Identify high-strength bolted slip-critical, direct-tension, or tensioned shear/bearing connections.

SECTION 05120 – STRUCTURAL STEEL

- B. Manufacturer's Mill Certificate: Steel certification for all steel used shall include chemistry, yield strength, and mill numbers.
- C. Galvanizing Certifications.
- D. Galvanizing Repair Method and Materials.
- E. Welding Procedures.
- F. Welders Certificates: Certify welders employed in the work, verifying AWS qualification within the previous 12 months.
- G. Provide fabrication shop QA/QC Plan for review by ENGINEER. Provide qualification data for firms and/or persons to demonstrate their capabilities and experience. Include lists of projects with project names and addresses, and names and addresses of engineers, architects and owners.

1.4 QUALITY ASSURANCE

- A. Fabricate and install structural steel in accordance with AISC Code of Standard Practice.
- B. Quality Assurance. The metal fabricator must have an ongoing quality assurance program approved by a qualified, independent source. At the option of the ENGINEER, the fabricator shall submit a copy of their operational quality assurance program, and shall not begin fabrication until the ENGINEER has approved this quality assurance program. The objectives of the quality assurance program are as follows:
 - 1. Completed products shall conform completely to all governing codes and specifications stipulated in the Design Contract Documents, and Plans.
 - 2. Quality Assurance Program is an integral part of the ongoing manufacturing activities of the Fabricator.

Although periodic inspections will be carried out by the ENGINEER, the purpose of these inspections is to note general conformance to the design documents. It is still the responsibility of the fabricator to produce a quality product, in complete conformance with the design documents, and to document and correct any non-conformance. All documentation, including that submitted, shall be kept on file by the fabricator, for review, if requested by the OWNER or ENGINEER.

- C. Fabrication Facility. The fabrication facility shall provide the proper environment and physical conditions necessary for welding, cutting, and general metal fabrication. The facility shall provide adequate work space, equipment, level surfaces, and protection from wind, moisture and freezing. The fabricator shall have the capability to carry out the following work in-house or on a contract basis:
 - Design of lifting and erection devices not shown on the drawings.
 - Preparation of shop fabrication drawings.
 - Receiving, checking and storing of materials for metal fabrication.

SECTION 05120 – STRUCTURAL STEEL

- Dimensional checking and verification.
 - Resolution of non-conformities.
 - Documentation of all stages of work with capability of tracing all major components.
 - Finishing, repairing, storing and shipping.
- D. Fabricator Qualifications: Fabricator must have completed metal fabrication work similar in material, design, and extent to that indicated for this Project, and with a record of successful in-service performance.
- E. Welding Standards: Comply with applicable provisions of AWS D1.1 Structural Welding Code - Steel, current edition,
1. Present evidence that each welder has satisfactorily passed AWS qualification tests for welding processes involved and, if pertinent, has undergone recertification.
 2. Submit welding procedures in accordance with AWS Structural Welding Codes.

1.5 DELIVERY, STORAGE AND HANDLING

- A. Deliver materials to Fabricator's shop in such quantities and at such times to ensure continuity of installation.
- B. Store materials to permit easy access for inspection and identification. Materials shall be protected during shipping and handling. Materials shall be stored above ground on pallets, platforms or other supports. Materials shall be kept clean and properly drained.
- C. Store fasteners in a protected place. Clean and re-lubricate bolts and nuts that become dry or rusty before use.
- D. Do not store materials or assembled structures in a manner that might cause distortion or damage to members or supporting structures. Repair or replace damaged materials or structures as directed.

PART 2 - PRODUCTS

- 2.1 MATERIALS - All materials for metal fabrication shall conform to the Design Contract Documents and as shown on the Design Plans. Purchase orders shall contain all necessary information to verify that materials purchased comply with the fore mentioned documents. The Fabricator shall inspect all materials, upon arrival, for conformance with the purchase orders. The Fabricator shall confirm that mill certificates and test reports are provided and that they correctly identify the materials delivered. If a supplier proposes a substitute for any material, the proposed substitution shall be submitted to the ENGINEER for approval prior to commencing any WORK involving use of the proposed substitute material. Supplier must be prepared to supply materials as identified on the design documents if the proposal for a substitution is not approved by the ENGINEER.
- A. Miscellaneous steel shapes and all plate steel shall be ASTM A36, hot-dip galvanized, unless otherwise noted.

SECTION 05120 – STRUCTURAL STEEL

- B. W Shapes shall conform to ASTM A572 – Grade 50 or ASTM A992
- C. Bolts shall conform to ASTM A 325, Type 1 heavy hex head steel structural bolts with ASTM A563 Grade DH heavy hex head carbon-steel nuts, and ASTM F436 Type 1 hardened carbon steel washers all with hot dip galvanized finished per ASTM A123

2.2 METAL COATINGS

- A. Unless otherwise noted, all steel shall be hot-dip galvanized in accordance with ASTM A123 or A153 as appropriate.

PART 3 - EXECUTION

3.1 METAL FABRICATION

- A. Shop Inspection: The CONTRACTOR shall furnish the ENGINEER with 30 days notice of the beginning of WORK at the mill or in the shop so that special fabrication inspections may be scheduled by the ENGINEER.
- B. Fabricate and assemble components in a shop, to greatest extent possible. Workmanship and finish shall be equal to the best industry standards and in accordance with the requirements of AWS, AISC, and The Aluminum Association, as applicable.
 - 1. Mark and match-mark materials for field assembly.
 - 2. Fabricate for delivery in a sequence that will expedite erection and minimize field handling.
 - 3. Thermal Cutting: Perform thermal cutting by machine to greatest extent possible.
 - 4. Holes: Drill holes perpendicular to metal surfaces; do not flame-cut holes or enlarge holes by burning.
 - 5. Aluminum Fabrication: Edges shall be cut true, smooth and free of burrs. Flame cutting is not permitted. Corner edges shall be ground smooth. Holes shall be drilled or punched. Weld spatter and flash marks shall be removed and ground smooth. Mill stamps and markings shall be removed from all exposed surfaces.
- C. Structural material, either plain or fabricated, shall be stored at the fabricating shop above ground, on platforms, skids or other supports. It shall be kept free from dirt, grease or other foreign matter, and shall be protected, as far as practical, from corrosion.
- D. All holes required for steel hot-dip galvanizing shall be clearly identified on the Shop Fabrication Drawings for ENGINEER review and approval. Fabricator shall coordinate with Galvanizer to determine size and quantity of holes required. Some, or all of the holes, may be required to be fully repaired per AWS D 1.1, at the discretion of the ENGINEER.

3.2 METAL ERECTION

- A. General: The CONTRACTOR shall provide and later remove all falsework, temporary shoring, and bracing necessary for erection and to complete assembly. All such devices shall be properly designed and constructed by the CONTRACTOR to meet anticipated construction and handling loads.

SECTION 05120 – STRUCTURAL STEEL

- B. Handling and Storing of Materials: Material to be stored shall be placed on skids above the ground. It shall be kept clean and properly drained. Girders and beams shall be placed upright and shored. Handling and erection procedures shall be conducted in a manner to avoid over stressing any structural element. Stress and deflection calculations shall be provided by the CONTRACTOR, as deemed necessary by the ENGINEER, for any erection procedure.
- C. Method and Equipment: Before starting the WORK of erection, the CONTRACTOR shall inform the ENGINEER fully as to the method of erection proposed, and the amount and character of equipment proposed to be used. Approval by the ENGINEER shall not be considered as relieving the CONTRACTOR of the responsibility for the safety of his method and equipment, or from carrying out the WORK in full accordance with the Plans and Specifications.
- D. Assembling: Metal parts shall be accurately assembled as shown on the Plans, following applicable Industry Standards, Codes, erection drawings and fabricators' match-marks. Excessive force or manipulation of parts shall not be allowed as determined by the ENGINEER. The material shall be carefully handled so that no parts will be bent, broken, or otherwise damaged. Hammering, which will injure or distort the members will not be permitted. Bearing surfaces shall be cleaned before the members are assembled.
- E. Bolt Holes and Bolting: Bolt holes and bolting shall follow the requirements as stated on the Plans and as indicated by applicable Industry Standards and Codes. Any steel to steel connections noted to be considered "slip-critical" shall be installed by the "turn-of-nut" tightening method per AISC. In addition to the requirements of AISC, bolting of slip-critical joints shall proceed in the following manner:
1. The joint shall be fitted up and aligned with drift pins.
 2. Sufficient force shall be applied so as to bring the faying surfaces of steel into close contact. If high strength bolts are used for this purpose (i.e. used to pull steel into position), they shall be clearly marked for identification, and not used in the final connection.
 3. High strength bolts shall be installed and brought up to snug-tight condition, such as can be produced by a few blows of an impact wrench, or by an ordinary spud wrench.
 4. High strength bolts shall then be tightened by turn-of-nut method, progressing from the most rigid part of the joint toward the free edges.
 5. Bolts used to pull steel into position (mentioned above) shall then be removed, replaced with high strength bolts, and tightened as described above.
 6. The impact wrench used for bolt tightening shall be of adequate capacity so as to provide the required tightening in approximately 10 seconds.
 7. Bolt lengths shall be such that 0" to ¼" of the bolt shall extend past the end of the nut after tightening.
- F. Welding: All welding shall be in accordance with AWS D1.1 or AWS D1.2, current edition, as applicable. All welders shall be qualified per AWS for the type of welding anticipated. Welds will be spot tested by the ENGINEER by VT, MT, or UT and any welds which fail shall be repaired at the CONTRACTOR's expense, which will also include all costs for retesting. No welding through galvanized coatings will be permitted.

SECTION 05120 – STRUCTURAL STEEL

The galvanizing within one inch of the weld shall be removed and repaired, after welding, according to these Specifications. All weld filler metal shall have chemistry similar to the base metal and shall have a minimum Charpy Impact Test Value of 20 ft-lbs. at -20 degrees F and have chemistry similar to the base metal. Filler metals shall only be used in welding positions recommended by the manufacturer. Welding materials shall be stored, and the condition maintained, according to AWS.

G. Galvanize Repair: Galvanizing and thermal sprayed metalizing coatings damaged due to fabrication, welding, material handling or occurring during installation shall be repaired by using the following hot-applied repair stick method:

1. Repair sticks shall be zinc-cadmium alloys (melting point 518° - 527°F) such as “Rev-Galv”, or zinc-tin-lead alloys (melting point 446° - 500°F) such as “Galv-Weld”, “Zilt”, and “Galv-over”. The zinc-tin -lead alloys shall comply with U.S. Federal Specification O-G-93 and contain fluxing agents.
2. Remove welding slag by chipping hammer and clean weld or damaged area by vigorous wire brushing.
3. Preheat the region to be repaired by means of an oxyacetylene torch or other convenient method to between 600°F and 750°F. The alloys do not spread well at temperatures lower than 600°F. Also as temperatures rise above 600°F increasing amounts of dross form.
4. Wire brush surface again.
5. Apply coating by rubbing bar of the alloy over the heated surface while it is hot enough to melt the alloy.
6. Spread the molten alloy by briskly wire brushing or rubbing with a flat edge strip of steel or palette knife. Minimum thickness of applied zinc stick material shall be 12 mils.
7. Remove flux residues by wiping with a damp cloth or rinsing with water.
8. Brush apply two top coats of zinc rich paint, ZRC or equal (cold galvanize repair).

END OF SECTION

WRANGELL MARINE SERVICE CENTER – BOAT HAULOUT PIER STRUCTURAL UPGRADES
 SUBMITTAL REGISTER
 Page 1 of 6

NOTE: The list below is not all-inclusive. In addition to the requirements below, the Contractor must comply with all submittal requirements identified in the plans, specifications and directions by the Engineer.

Spec. Division	Article	Description	Date Rec'd from Cont'r	Reviewer	Action Code	Date FWD to Cont'r	Remarks
CONTRACTOR: _____							
ACTION CODES: NR: NOT REVIEWED NET: NO EXCEPTION TAKEN SSI: SUBMIT SPECIFIED ITEM AN: APPROVED AS NOTED MCN: MAKE CORRECTIONS NOTED RR: DISAPPROVED, REVISE AND RESUBMIT R: REJECTED							
00360 (00830) (00840)	- (C) (A)	List of Subcontractors with Contact Information, Schedules, and Sales Tax Forms					
00500	-	Agreement Form					
00610	-	Performance Bond					
00620	-	Payment Bond					
00700	5.2 C	Insurance Policy Certificates					
00700	6.2 E	Evidence of Quality of Materials (reports or tests)					
00700	6.3	Monthly Updates of the Progress Schedule					
00700 (01300)	6.4 (1.1 B1)	Proposed Substitutes or "Or-Equal" Items					

CITY AND BOROUGH OF WRANGELL WRANGELL MARINE SERVICE CENTER BOAT HAULOUT PIER STRUCTURAL UPGRADES



LOCATION MAP

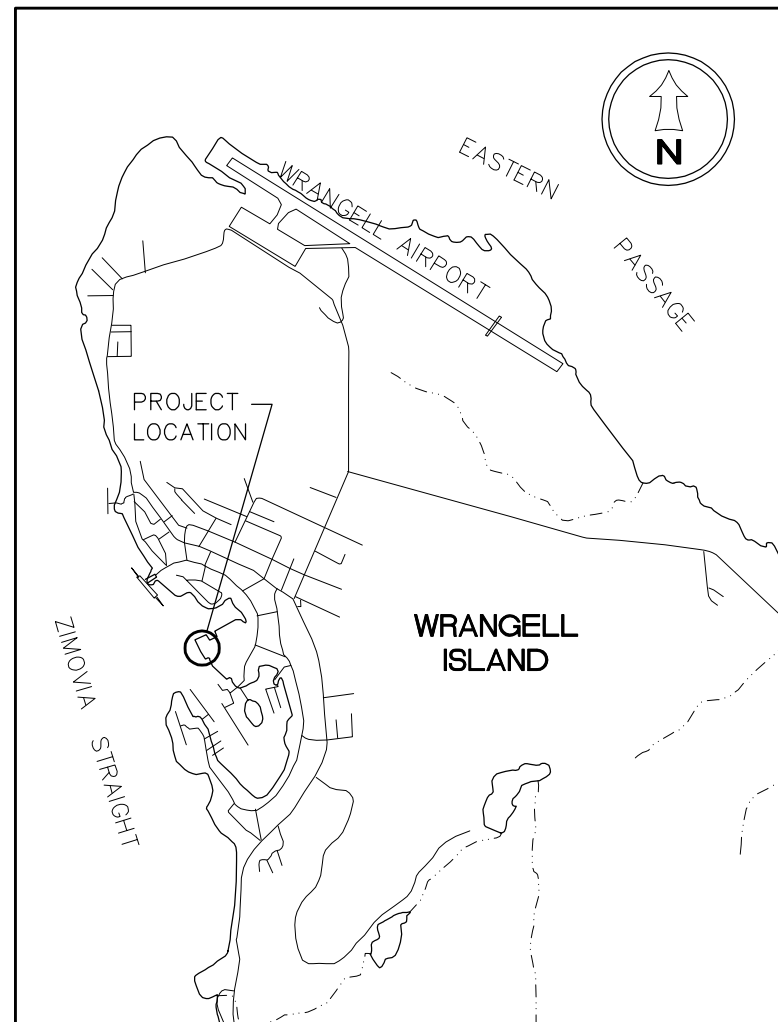

VICINITY MAP

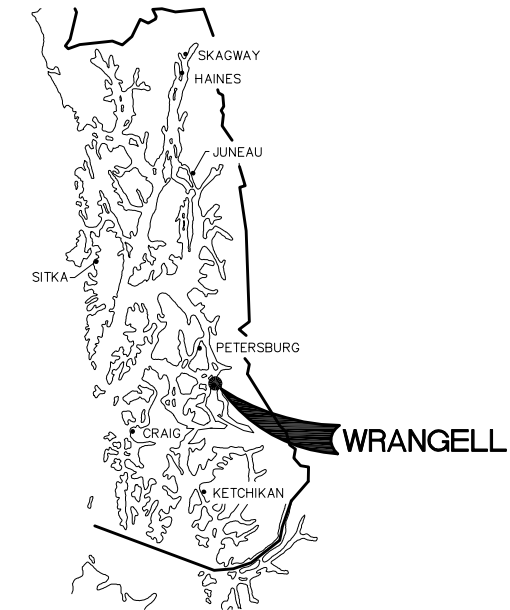

SOUTHEAST ALASKA

PROJECT SCHEDULE	
DESCRIPTION	SCHEDULE
1. SUBSTANTIAL COMPLETION	OCTOBER 1, 2013
2. FINAL COMPLETION OF ALL WORK UNDER THIS CONTRACT.	NOVEMBER 1, 2013

NOTE: SEE SECTION 01010 FOR SPECIAL CONDITIONS IN TIME FOR ACCESSING THE SITE

DESIGN PARAMETERS:

APPLICABLE CODES:

AASHTO – American Association of State Highway and Transportation Officials
Standard Specifications for Highway Bridges, 17th Edition, 2002

DOCK LIVE LOADS:

Truck: ASSHTO HS20-44
Forklift: 100 ton Axle (200,000 lbs Axle, 100,000 lbs Wheel)
Travelift: 300 BFM (300 ton) Boat lift
Uniform Load: 1000 psf

DOCK EARTHQUAKE LOAD: Equivalent static lateral load of 0.20 * (Dead Load) any direction.

DRAWING INDEX		
SHEET NO.	DWG. NO.	SHEET TITLE
GENERAL		
1 OF 9	1.01	COVER SHEET, VICINITY MAP AND DRAWING INDEX
2 OF 9	1.02	SITE CONSTRUCTION STAGING PLAN
3 OF 9	1.03	OVERALL DOCK PLAN
BOAT HAULOUT DOCK		
4 OF 9	2.01	DOCK PLAN
5 OF 9	2.02	TYPICAL SECTIONS
6 OF 9	2.03	TYPICAL SECTIONS AND DETAILS
7 OF 9	2.04	BACK WALL ABUTMENT
8 OF 9	2.05	PILE CAPS AND SUB-PILE CAPS
9 OF 9	2.06	DECK DETAILS

REVISIONS					
REV.	DATE	DESCRIPTION	DWN.	CKD.	APP.

9360 Glacier Highway Ste 100
Juneau, Alaska 99801
Phone: 907-586-2093
Fax: 907-586-2099
www.pndengineers.com

DESIGN: CMG CHECKED: CRS SCALE: _____

DRAWN: DD APPROVED: _____

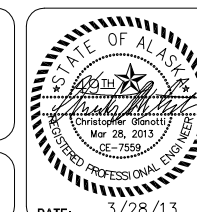

CITY AND BOROUGH OF WRANGELL, ALASKA
WRANGELL MARINE SERVICE CENTER
BOAT HAULOUT PIER STRUCTURAL UPGRADES

SHEET TITLE:
**COVER SHEET, VICINITY MAP
AND DRAWING INDEX**

PND PROJECT NO.: 122056.01 DWG. FILE: 1.01.DWG

1.01

SHEET
1 OF 9

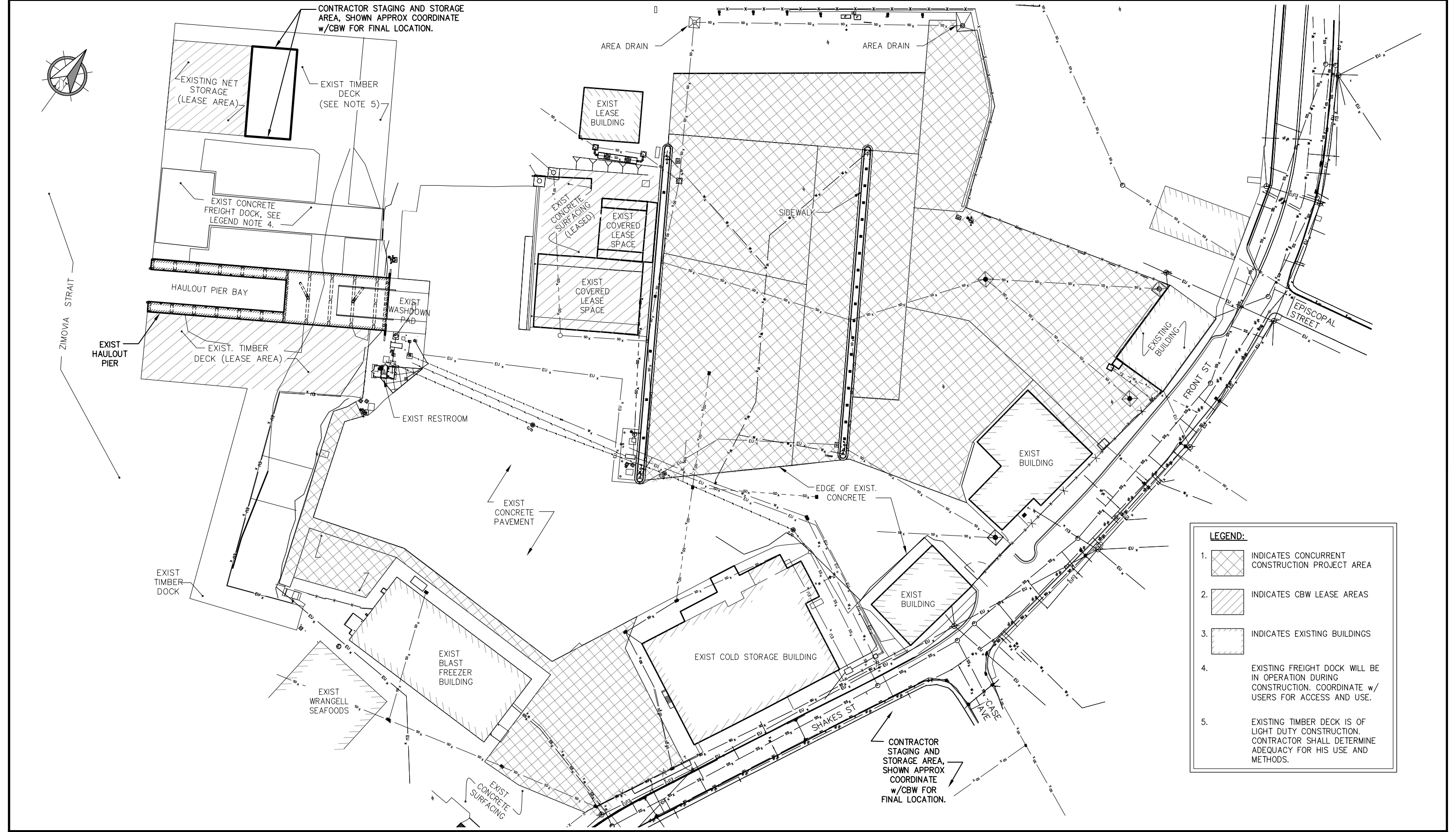

LEGEND:

1. [Cross-hatched box] INDICATES CONCURRENT CONSTRUCTION PROJECT AREA
2. [Diagonal hatched box] INDICATES CBW LEASE AREAS
3. [Solid box] INDICATES EXISTING BUILDINGS
4. EXISTING FREIGHT DOCK WILL BE IN OPERATION DURING CONSTRUCTION. COORDINATE w/ USERS FOR ACCESS AND USE.
5. EXISTING TIMBER DECK IS OF LIGHT DUTY CONSTRUCTION. CONTRACTOR SHALL DETERMINE ADEQUACY FOR HIS USE AND METHODS.

REVISIONS

REV.	DATE	DESCRIPTION	DWN.	CKD.	APP.

PND ENGINEERS, INC.

9360 Glacier Highway Ste 100
Juneau, Alaska 99801
Phone: 907-586-2093
Fax: 907-586-2099
www.pndengineers.com

DESIGN: CG CHECKED: CG
DRAWN: WRB APPROVED: CRS

SCALE: SCALE IN FEET
0 40 80 FT.

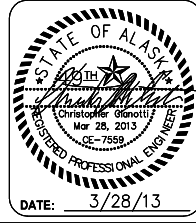

**CITY AND BOROUGH OF WRANGELL, ALASKA
WRANGELL MARINE SERVICE CENTER
BOAT HAULOUT PIER STRUCTURAL UPGRADES**

SHEET TITLE: **SITE CONSTRUCTION STAGING PLAN**

DATE: 3/28/13

PND PROJECT NO.: 122056.01 DWG. FILE: 1.02.DWG

1.02
SHEET 2 OF 9

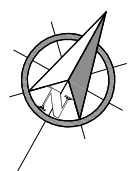

40'x80' STAGING AREA SHOWN APPROX. COORDINATE FINAL LOCATION WITH CBW HARBORMASTER

EXISTING NET STORAGE LEASE AREA

EXIST. TIMBER DOCK

EXIST. TIMBER PILE, TYP.

EXIST. TIMBER PILE CAP, TYP.

TP-2

TP-3

TP-1

TP-4

TP-5

TP-6

TP-7

REMOVE AND REPLACE EXIST TIMBERS AS REQUIRED TO INSTALL BATTER PILES, TYP.

EXIST. HAULOUT BAY

EXIST. HAULOUT PIER SEE S2.01

EXIST. STRUCTURE

LEASE SPACE

EXIST DECK WEAR COURSE, TYP.

EXISTING MUDLINE ELEV. APPROX.

EXIST TIMBER DOCK

EXIST CONCRETE DECK, PILE-SUPPORTED HAULOUT PIER

NOTE:
THE CONTRACTOR SHALL BE ADDITIONALLY RESPONSIBLE TO REMOVE DEBRIS LAYING ON THE SEAFLOOR AT ALL PILE LOCATIONS BY GRAPPLING, CLAMSHELL BUCKET, DIVING, ETC. TO CLEAR THE AREA FOR PILE DRIVING OPERATIONS.

EXISTING BATTER CLUSTER UNDER DOCK, TYP.

EXIST. CONCRETE LIMITS, TYP.

OVERALL DOCK PLAN

REVISIONS

REV.	DATE	DESCRIPTION	DWN.	CKD.	APP.



9360 Glacier Highway Ste 100
Juneau, Alaska 99801
Phone: 907-586-2093
Fax: 907-586-2099
www.pndengineers.com

DESIGN: CMG CHECKED: CRS
DRAWN: DD APPROVED: _____
SCALE: SCALE IN FEET
0 30 60 FT.



**CITY AND BOROUGH OF WRANGELL, ALASKA
WRANGELL MARINE SERVICE CENTER
BOAT HAULOUT PIER STRUCTURAL UPGRADES**

SHEET TITLE:
OVERALL DOCK PLAN
PND PROJECT NO.: 122056.01 DWG. FILE: 1.03.DWG

1.03
SHEET
3 OF 9

DATE: 3/28/13

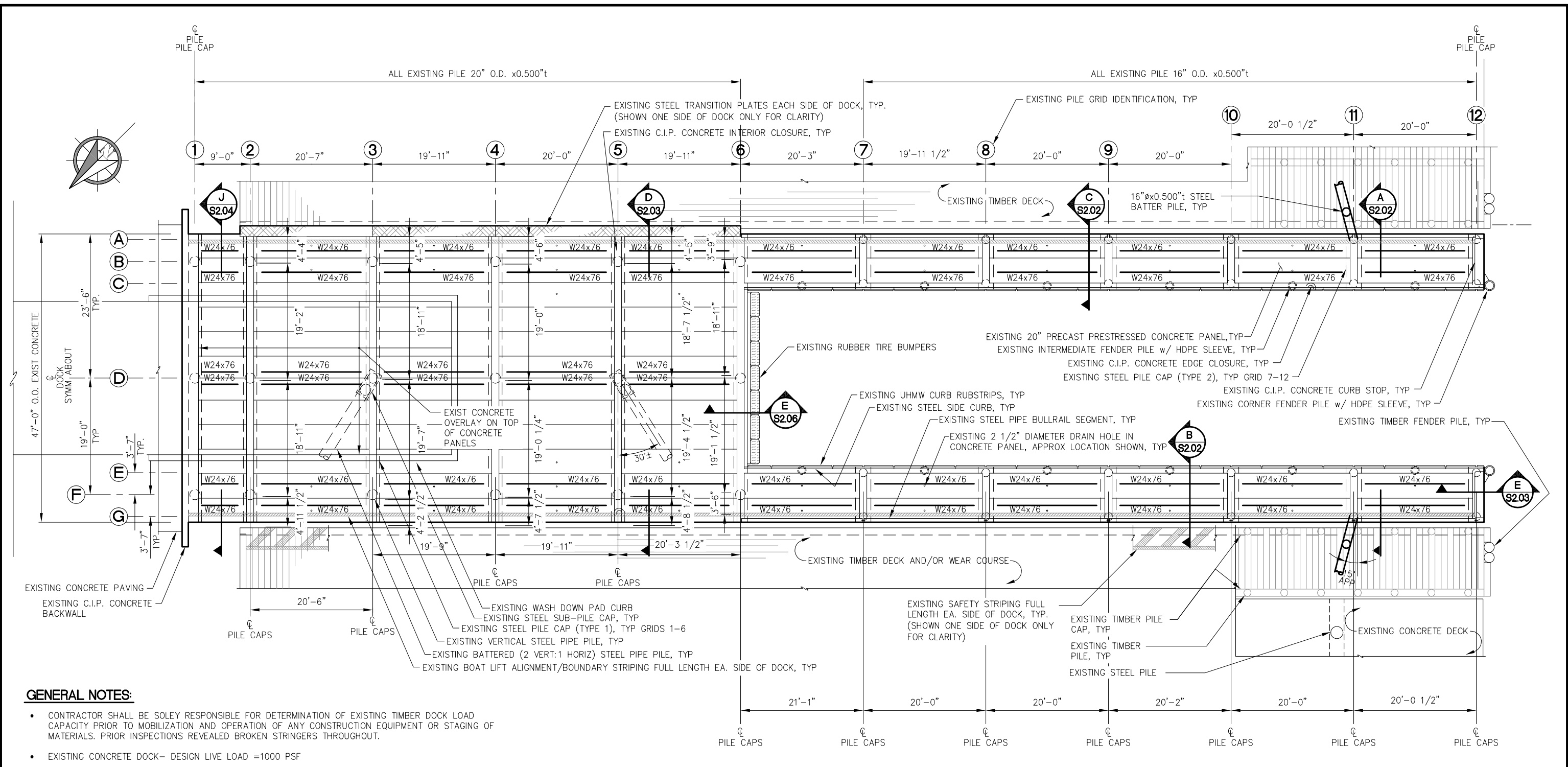

GENERAL NOTES:

- CONTRACTOR SHALL BE SOLEY RESPONSIBLE FOR DETERMINATION OF EXISTING TIMBER DOCK LOAD CAPACITY PRIOR TO MOBILIZATION AND OPERATION OF ANY CONSTRUCTION EQUIPMENT OR STAGING OF MATERIALS. PRIOR INSPECTIONS REVEALED BROKEN STRINGERS THROUGHOUT.
- EXISTING CONCRETE DOCK- DESIGN LIVE LOAD =1000 PSF
- ENTIRE WASH DOWN PAD NOT SHOWN FOR CLARITY

1 DOCK PLAN

REVISIONS					
REV.	DATE	DESCRIPTION	DWN.	CKD.	APP.

PND ENGINEERS, INC.

9360 Glacier Highway Ste 100
Juneau, Alaska 99801
Phone: 907-586-2093
Fax: 907-586-2099
www.pndengineers.com

DESIGN: CMG CHECKED: CRS
DRAWN: DD APPROVED: _____

SCALE: SCALE IN FEET
0 8 16 FT.



**CITY AND BOROUGH OF WRANGELL, ALASKA
WRANGELL MARINE SERVICE CENTER
BOAT HAULOUT PIER STRUCTURAL UPGRADES**

SHEET TITLE:
DOCK PLAN

PND PROJECT NO.: 122056.01 DWG. FILE: 2.01.DWG

S2.01
SHEET 4 OF 9

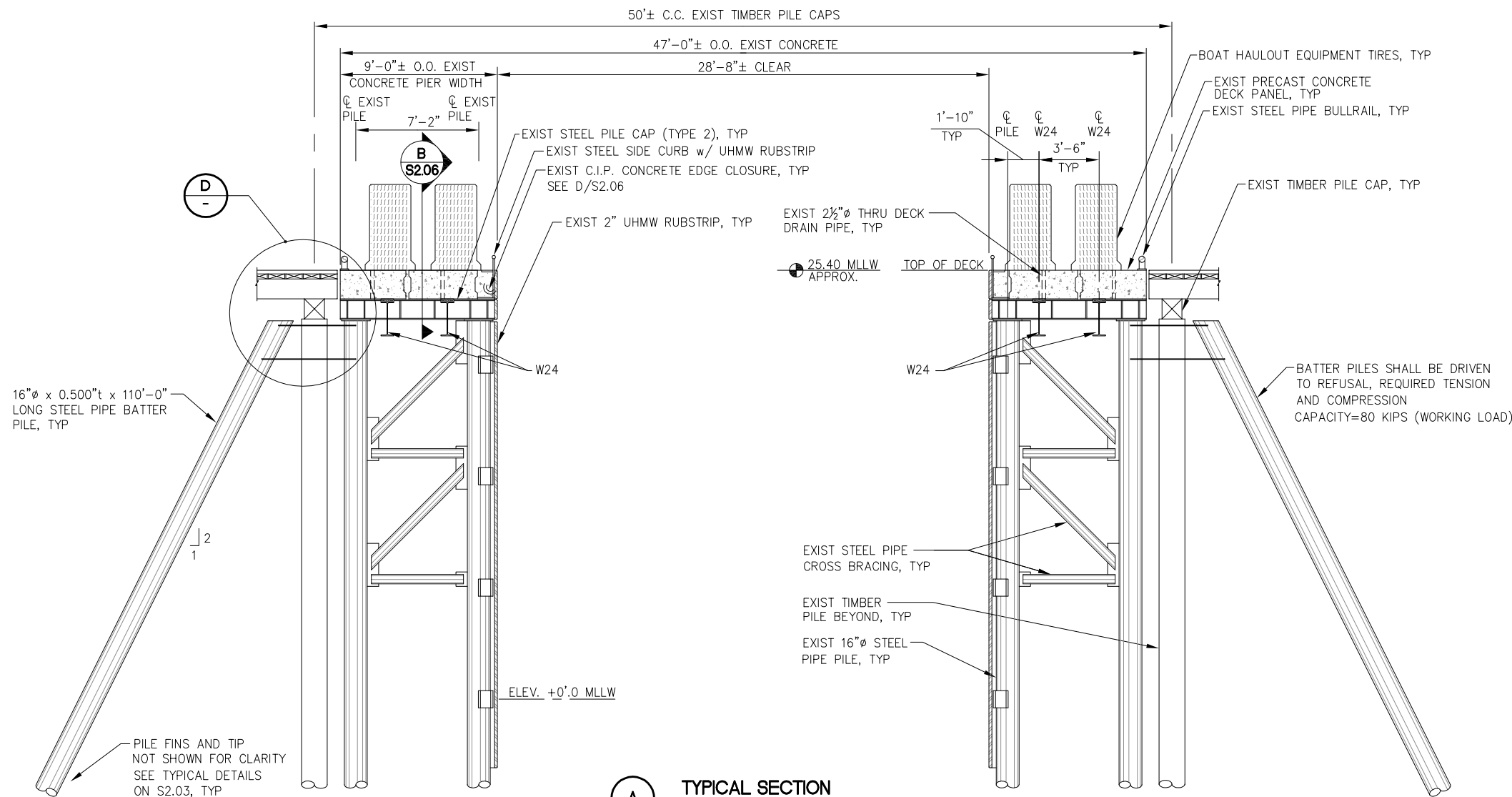

A TYPICAL SECTION

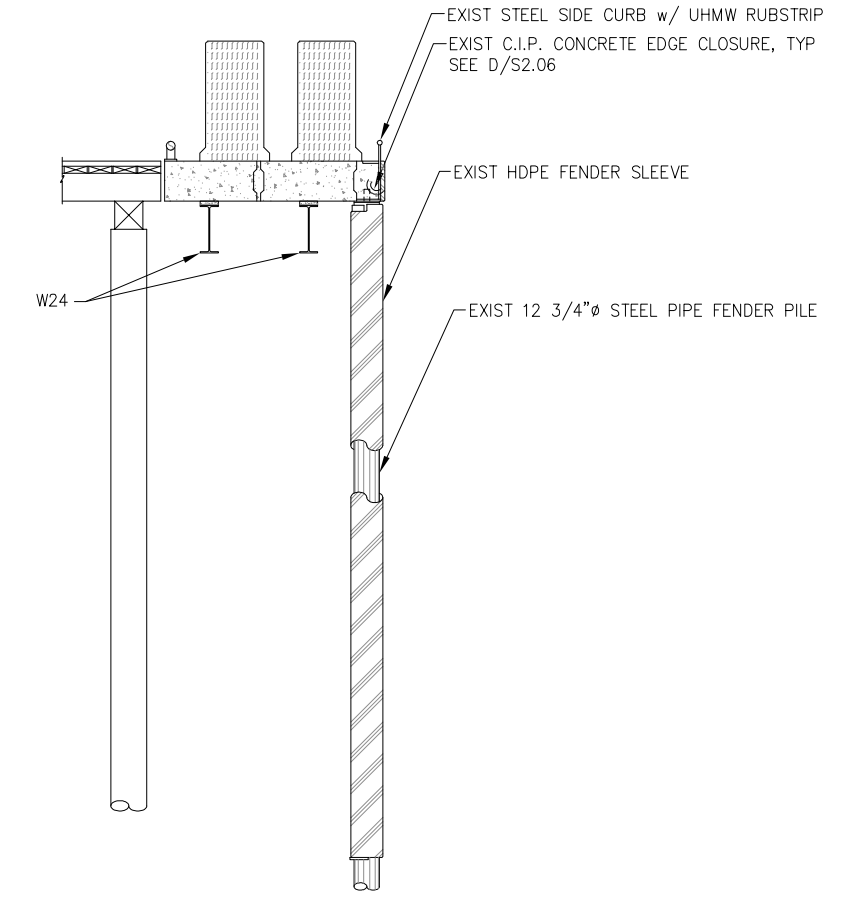

B SECTION AT INTERMEDIATE FENDER PILE

16"Ø x 0.500"t x 110'-0" LONG STEEL PIPE BATTER PILE, TYP

ROUGHEN UNDERSIDE OF CONCRETE WITH CHIPPING HAMMER, BRUSHING TOOL, SAND BLASTING OR OTHER MEANS

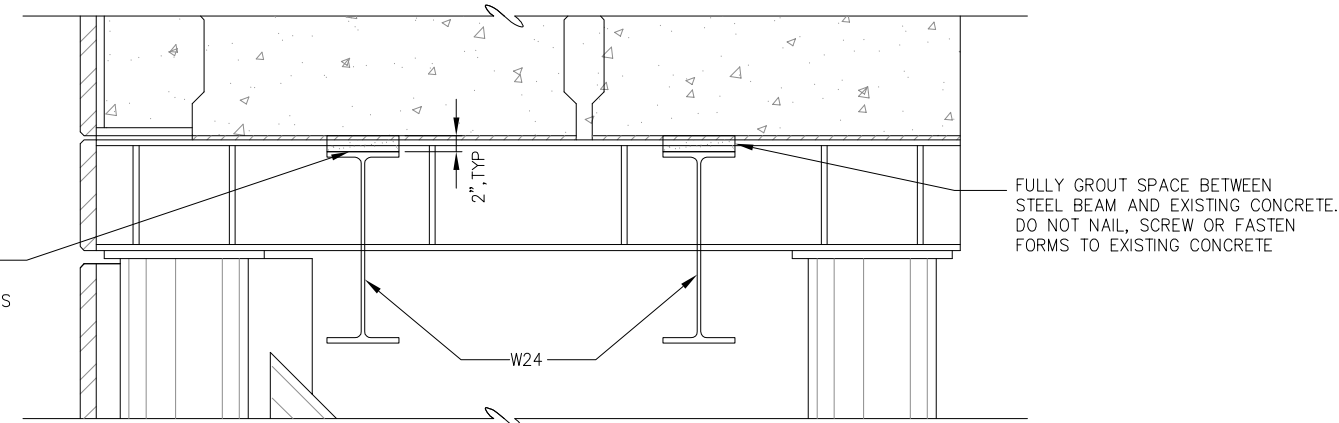

C BEAM TO CONCRETE PANEL GROUTING

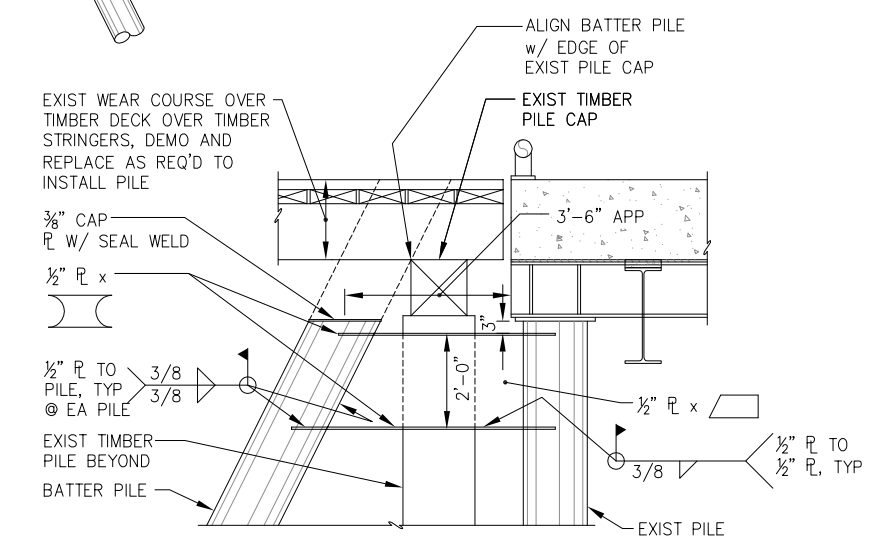

D BATTER PILE CONNECTION DETAIL

REVISIONS					
REV.	DATE	DESCRIPTION	DWN.	CKD.	APP.

PND ENGINEERS, INC.

9360 Glacier Highway Ste 100
Juneau, Alaska 99801
Phone: 907-586-2093
Fax: 907-586-2099
www.pndengineers.com

DESIGN: CMG CHECKED: CRS
DRAWN: DD APPROVED: _____

SCALE: _____



**CITY AND BOROUGH OF WRANGELL, ALASKA
WRANGELL MARINE SERVICE CENTER
BOAT HAULOUT PIER STRUCTURAL UPGRADES**

SHEET TITLE:
TYPICAL SECTIONS

SHEET 5 OF 9

PND PROJECT NO.: 122056.01 DWG. FILE: 2.02.DWG

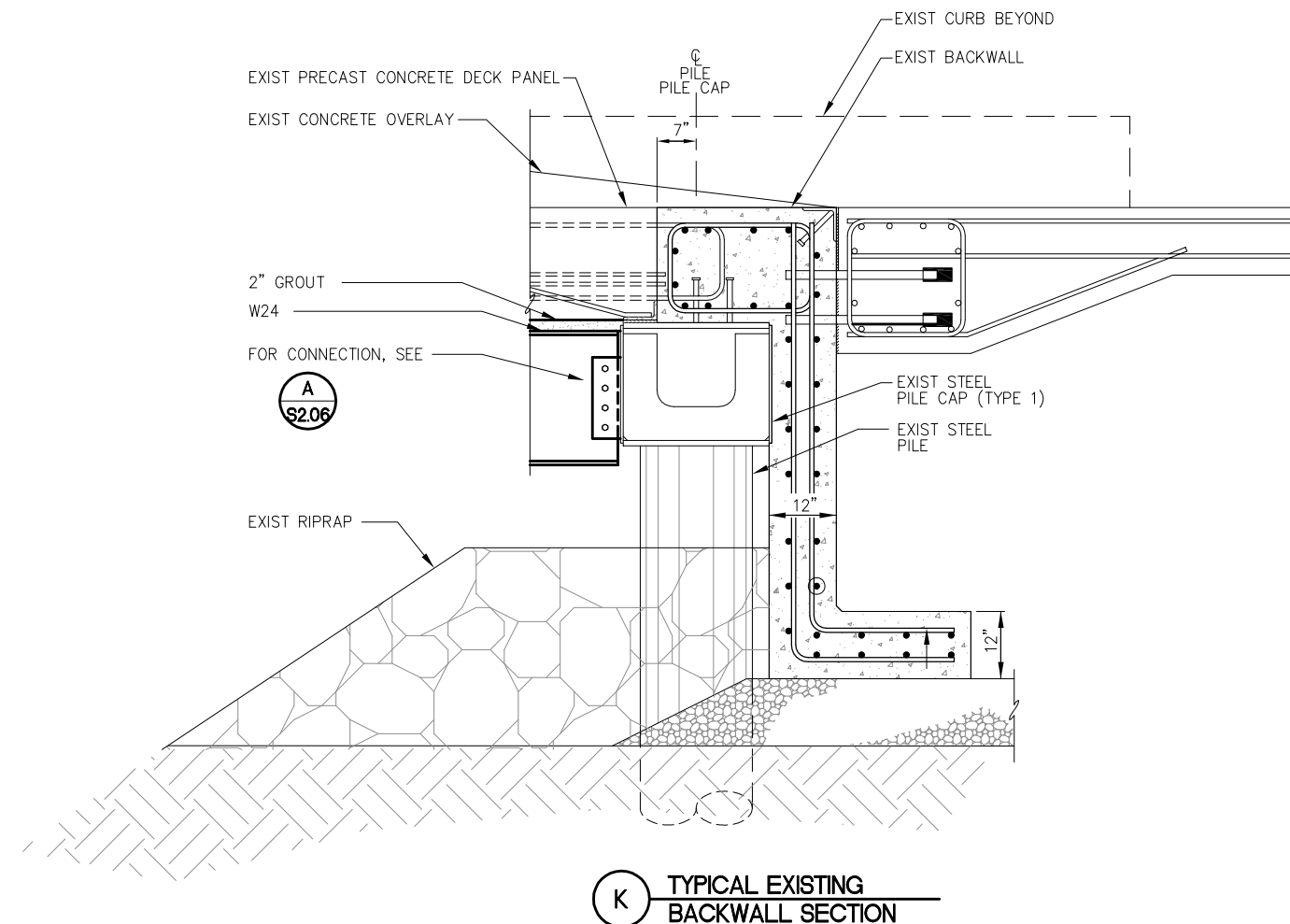
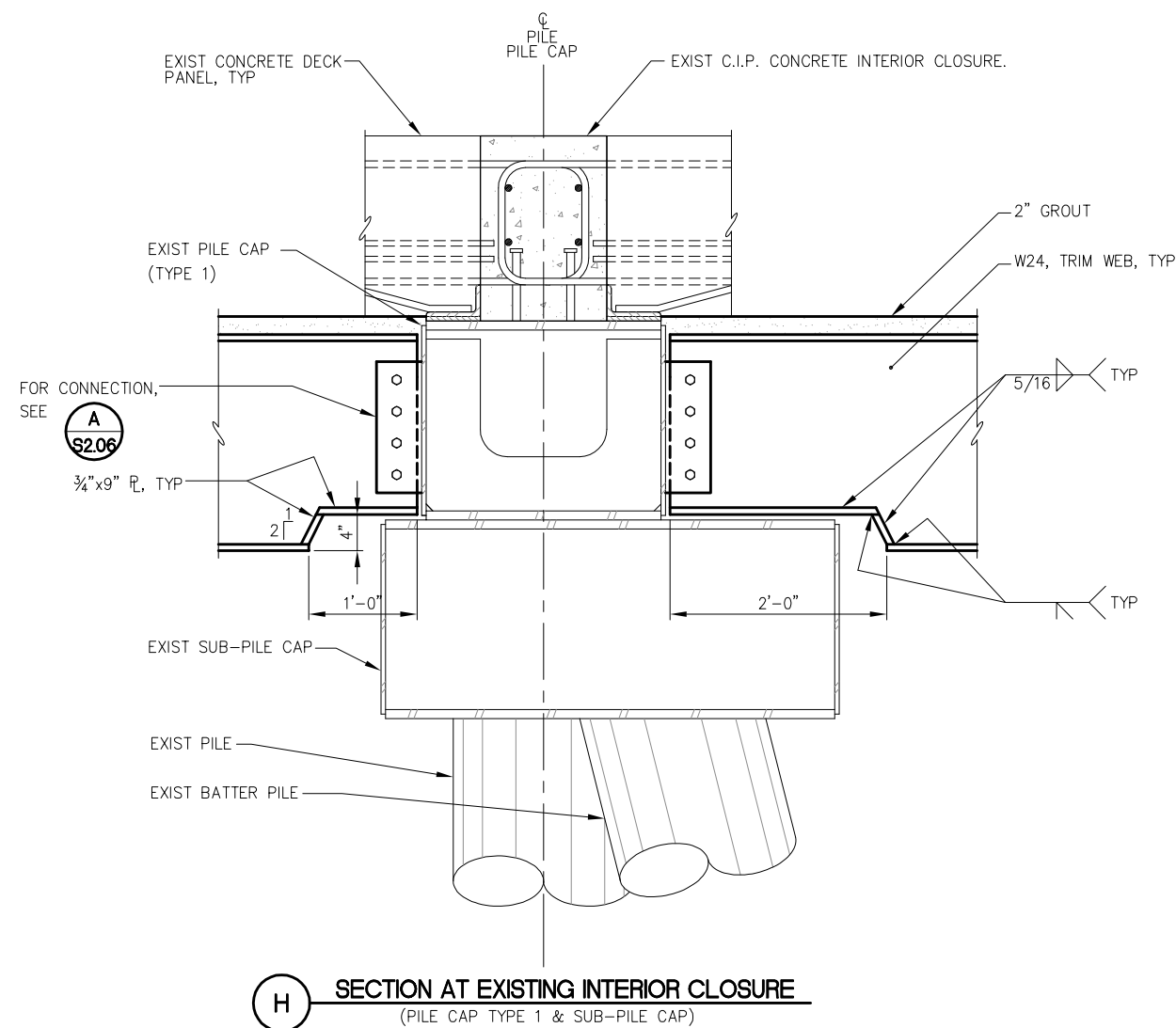
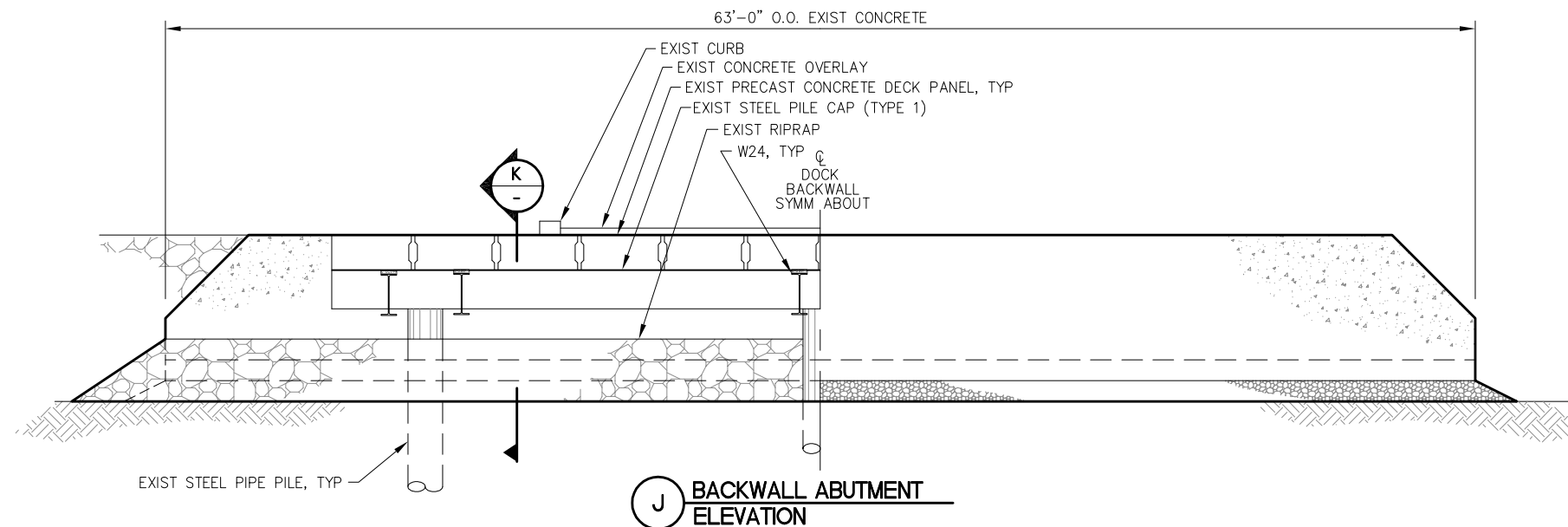

REVISIONS					
REV.	DATE	DESCRIPTION	DWN.	CKD.	APP.

PND
 ENGINEERS, INC.

9360 Glacier Highway Ste 100
 Juneau, Alaska 99801
 Phone: 907-586-2093
 Fax: 907-586-2099
 www.pndengineers.com

DESIGN: CMG CHECKED: CRS
 DRAWN: DD APPROVED: _____

SCALE: _____

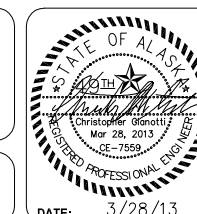

CITY AND BOROUGH OF WRANGELL, ALASKA
WRANGELL MARINE SERVICE CENTER
BOAT HAULOUT PIER STRUCTURAL UPGRADES

SHEET TITLE:
BACK WALL ABUTMENT

PND PROJECT NO.: 122056.01 DWG. FILE: 2.04.DWG

S2.04
 SHEET
 7 OF 9

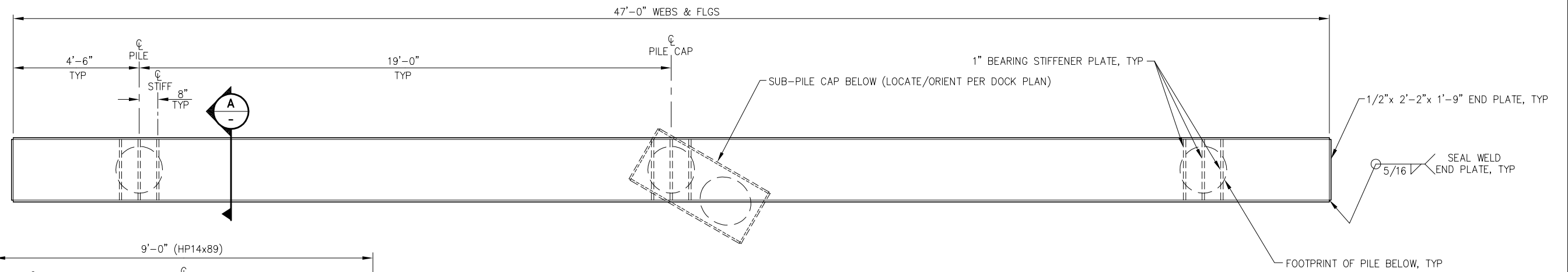

EXISTING PILE CAP TYPE 1 - PLAN
(6 TOTAL)

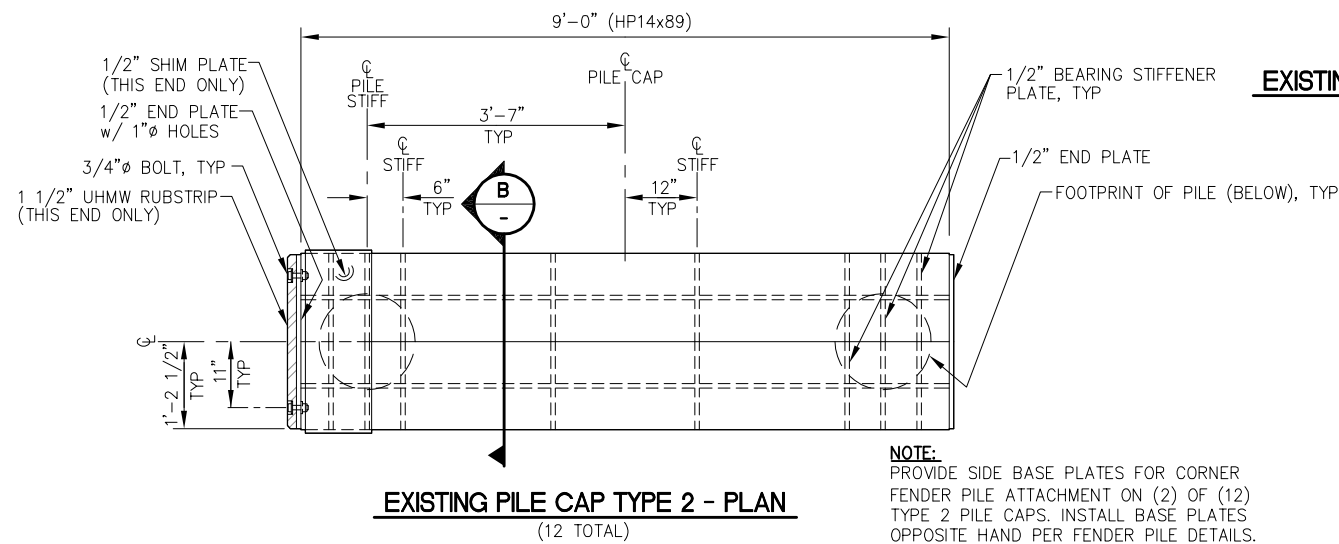

EXISTING PILE CAP TYPE 2 - PLAN
(12 TOTAL)

NOTE:
PROVIDE SIDE BASE PLATES FOR CORNER FENDER PILE ATTACHMENT ON (2) OF (12) TYPE 2 PILE CAPS. INSTALL BASE PLATES OPPOSITE HAND PER FENDER PILE DETAILS.

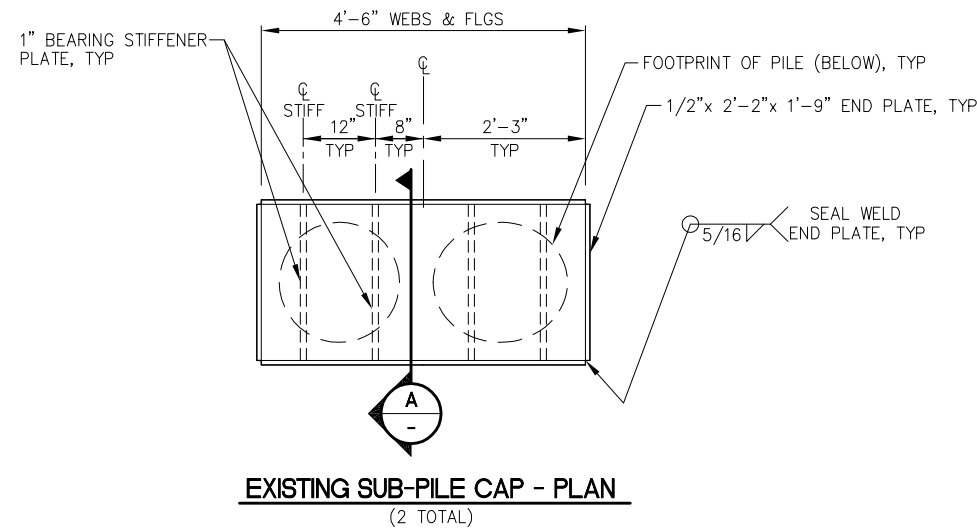

EXISTING SUB-PILE CAP - PLAN
(2 TOTAL)

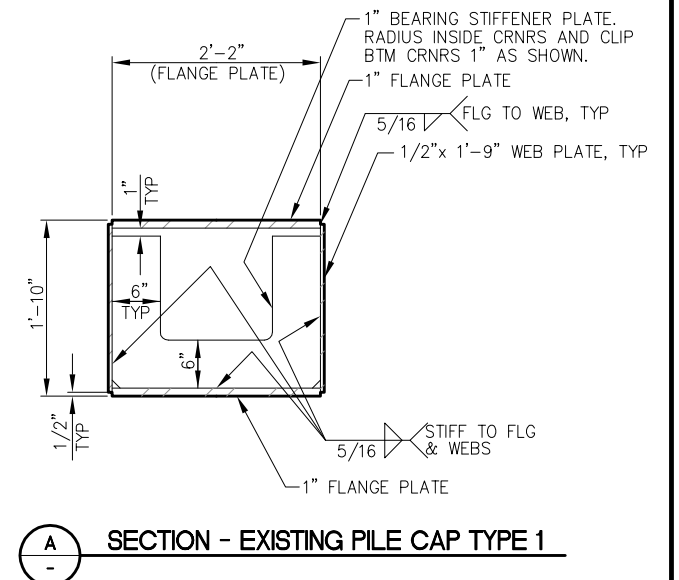

SECTION - EXISTING PILE CAP TYPE 1

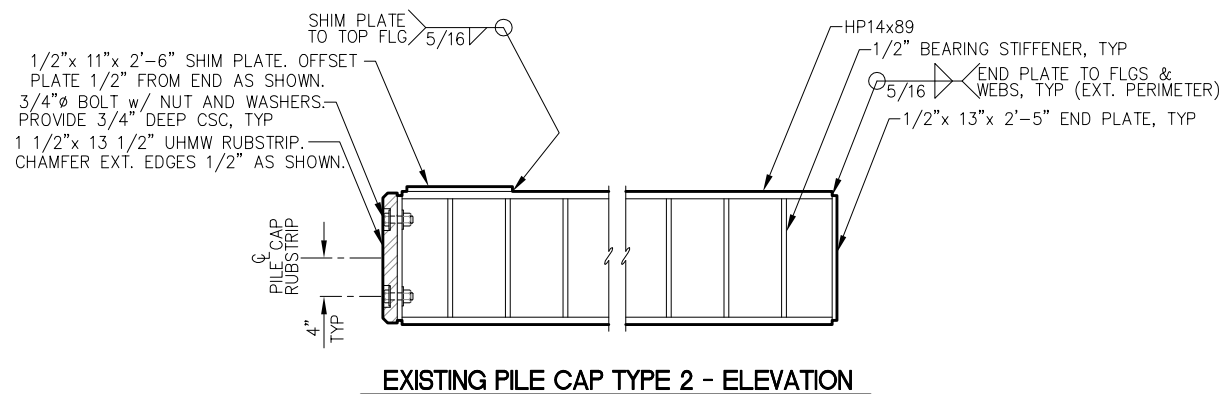

EXISTING PILE CAP TYPE 2 - ELEVATION

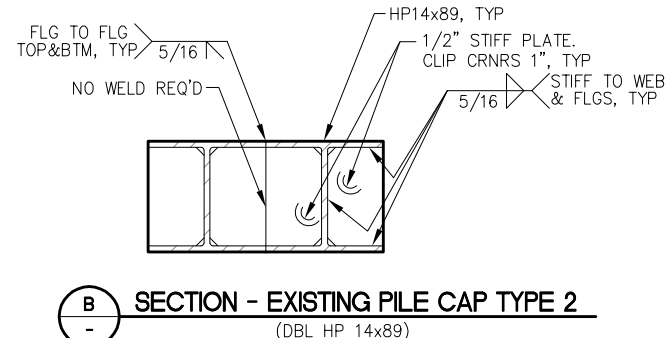

SECTION - EXISTING PILE CAP TYPE 2
(DBL HP 14x89)

NOTE:
ALL TYPE 1 PILE CAPS AND SUB-PILE CAPS SHALL BE SPRAY METALLIZED PER SPECIFICATIONS. ALL TYPE 2 PILE CAPS SHALL BE HOT-DIP GALVANIZED PER SPECS.

FOR REFERENCE ONLY.
ALL DETAILS ON THIS SHEET ARE EXISTING.

REVISIONS					
REV.	DATE	DESCRIPTION	DWN.	CKD.	APP.

PND ENGINEERS, INC.
9360 Glacier Highway Ste 100
Juneau, Alaska 99801
Phone: 907-586-2093
Fax: 907-586-2099
www.pndengineers.com

DESIGN: CMG CHECKED: CRS
DRAWN: DD APPROVED: _____

SCALE: _____



**CITY AND BOROUGH OF WRANGELL, ALASKA
WRANGELL MARINE SERVICE CENTER
BOAT HAULOUT PIER STRUCTURAL UPGRADES**

SHEET TITLE:
PILE CAPS AND SUB-PILE CAPS

SHEET NO. **8** OF **9**

PND PROJECT NO.: 122056.01 DWG. FILE: 2.05.DWG

DATE: 3/28/13

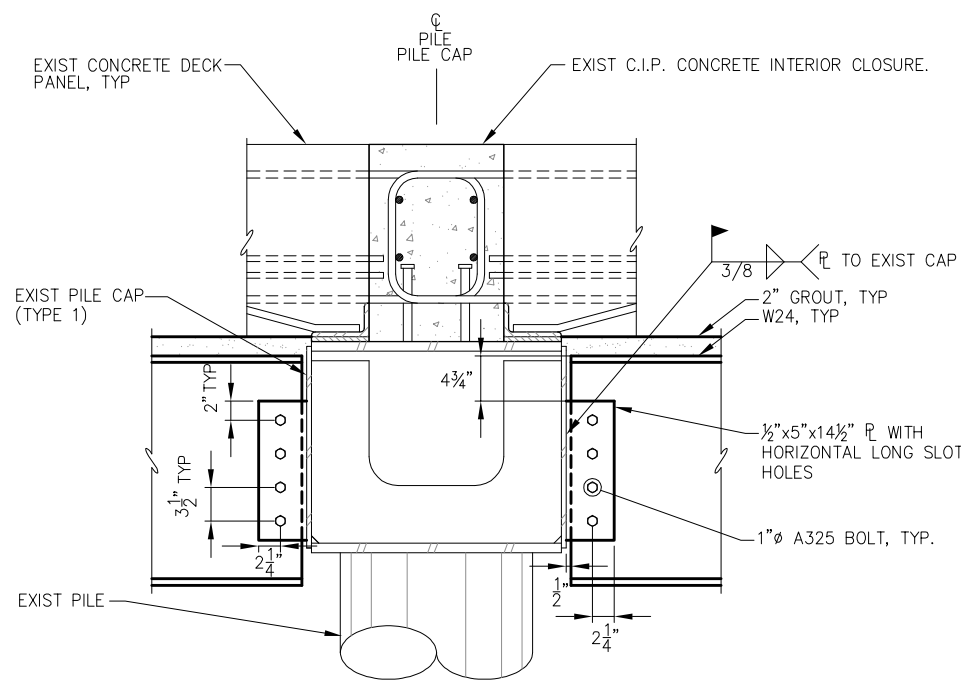

A SECTION AT EXISTING INTERIOR CLOSURE
(PILE CAP TYPE 1)

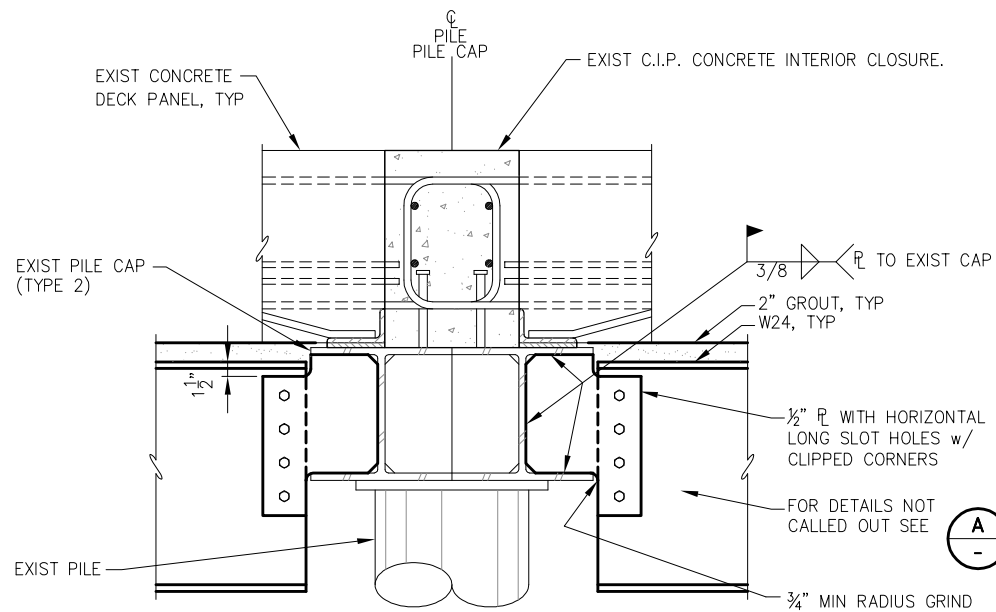

B SECTION AT EXISTING INTERIOR CLOSURE
(PILE CAP TYPE 2)

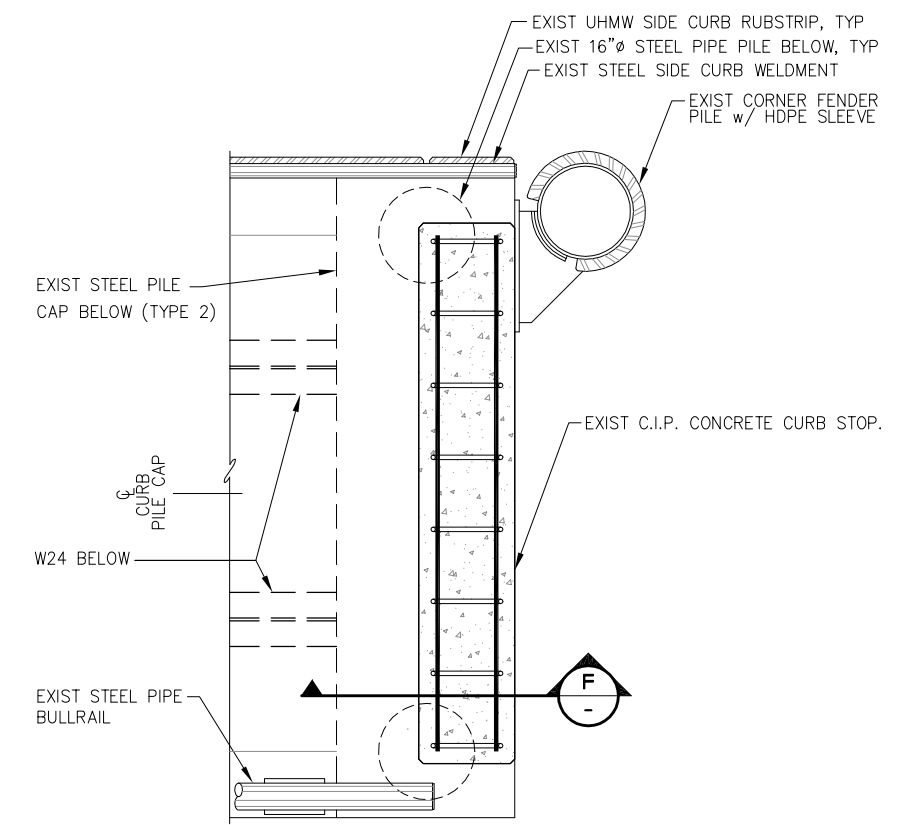

C EXIST C.I.P. CURB STOP - PLAN

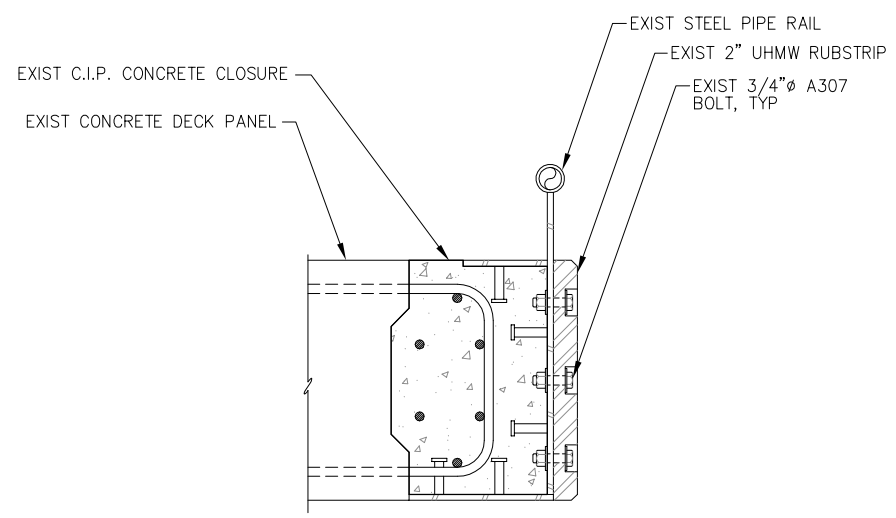

D SECTION AT SIDE CURB
(FOR REFERENCE ONLY)

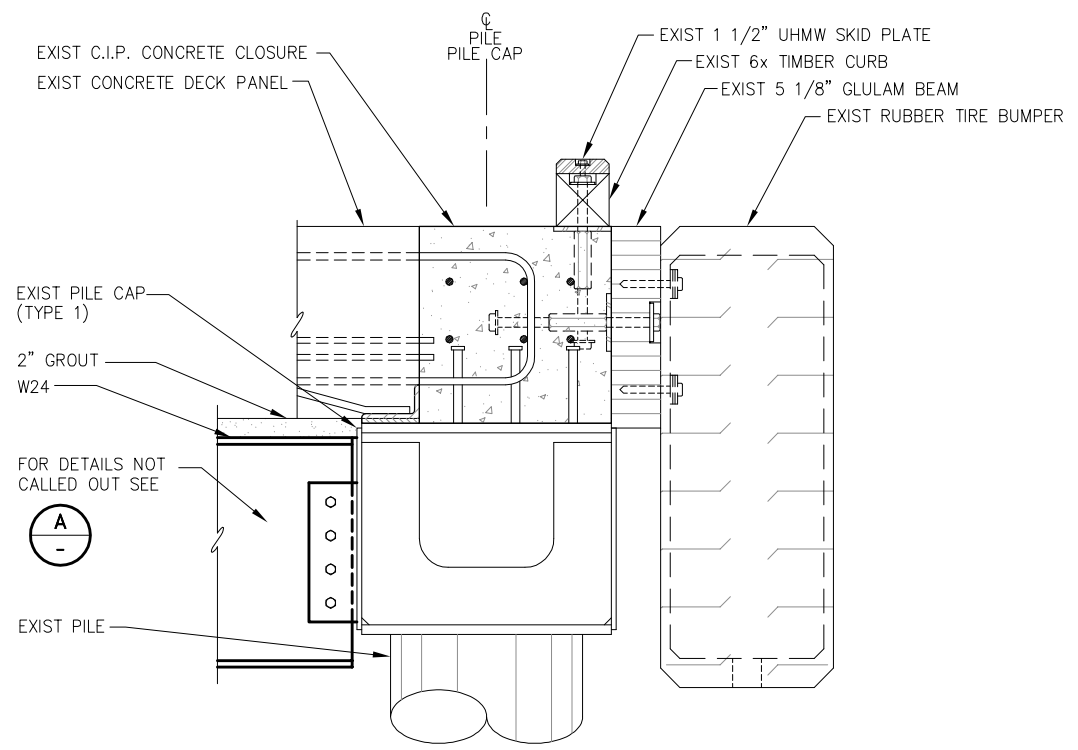

E SECTION AT END CURB

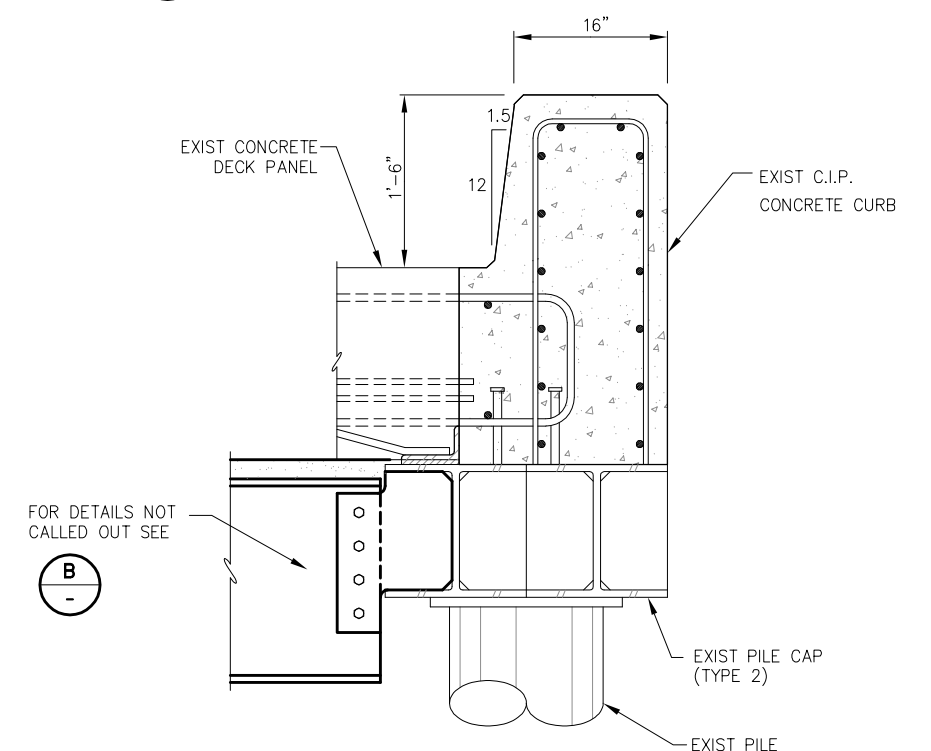

F SECTION AT C.I.P. CURB STOP

REVISIONS					
REV.	DATE	DESCRIPTION	DWN.	CKD.	APP.

PND ENGINEERS, INC.
 9360 Glacier Highway Ste 100
 Juneau, Alaska 99801
 Phone: 907-586-2093
 Fax: 907-586-2099
 www.pndengineers.com

DESIGN: CMG CHECKED: CRS SCALE:
 DRAWN: DD APPROVED: _____



**CITY AND BOROUGH OF WRANGELL, ALASKA
 WRANGELL MARINE SERVICE CENTER
 BOAT HAULOUT PIER STRUCTURAL UPGRADES**

SHEET TITLE:
DECK DETAILS

SHEET NO. **S2.06**
 SHEET 9 OF 9

PND PROJECT NO.: 122056.01 DWG. FILE: 2.06.DWG